

RCD Actuator Gripper Type

First Step Guide Second Edition

Thank you for purchasing our product.
Make sure to read the Safety Guide and detailed Instruction Manual (CD/DVD) included with the product in addition to this First Step Guide to ensure correct use.
This Instruction Manual is original.

Warning : Operation of this equipment requires detailed installation and operation instructions which are provided on the CD/DVD Manual included in the box this device was packaged in. It should be retained with this device at all times.
A hard copy of Manual can be requested by contacting your nearest IAI Sales Office listed at the back cover of the Instruction Manual or on the First Step Guide.

- Using or copying all or part of this Instruction Manual without permission is prohibited.
- The company names, names of products and trademarks of each company shown in the sentences are registered trademarks.

Product Check

This product is comprised of the following parts if it is of standard configuration.
If you find any fault in the contained model or any missing parts, contact us or our distributor.

1. Parts (The option is excluded.)

No.	Part Name	Model	Quantity	Remarks
1	Actuator	Refer to "How to Read the Model Nameplate" and "How to Read the Model Number."	1	
Accessories				
2	Motor • encoder cables <small>(Note1)</small>		1	
3	First Step Guide		1	
4	Instruction Manual (DVD)		1	
5	Safety Guide		1	

Note 1 Please refer to the wiring layout for the enclosed motor cable and encoder cable.

2. How to read the model plate

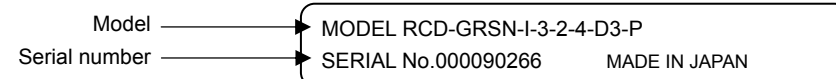

3. How to read the model No.

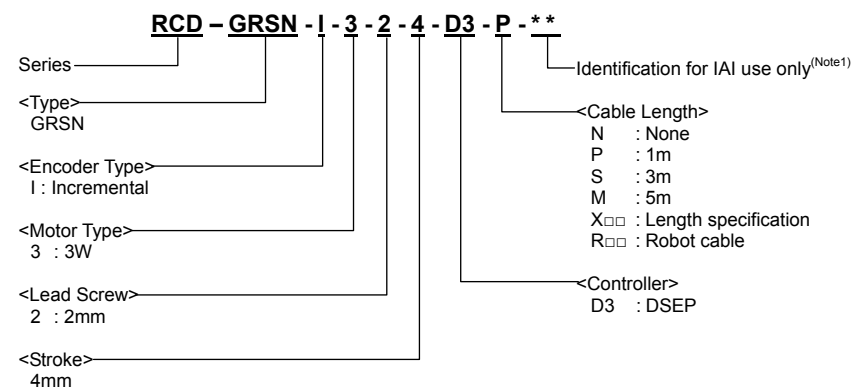

Note 1 Identification for IAI use only : It may be displayed for IAI use. It is not a code to show the model type.

[Refer to the catalog or Instruction Manual (DVD) for specification details.]

Precautions in Handling

- Handling the Packed Unit**
 - Do not damage or drop. The package is not applied with any special treatment that enables it to resist an impact caused by a drop or crash.
 - Transport a heavy package with at least more than two operators. Consider an appropriate method for transportation.
 - Keep the unit in a horizontal orientation when placing it on the ground or transporting. Follow the instruction if there is any for the packaging condition.
 - Do not step or sit on the package.
 - Do not put any load that may cause a deformation or breakage of the package.
- Handling the Actuator After Unpacking**
 - Do not carry the actuator by its motor unit or its cable or attempt to move it by pulling the cable.
 - Hold the frame or motor cover section of the body when transporting the actuator main body.
 - Do not hit or drop the actuator during transportation.
 - Do not attempt to force any part of the actuator. Do not apply excess force especially on the fingers, finger guide and levers.

Environments for Installation, Storage and Preservation

- Installation Environment**

The actuator should be installed in a location other than those specified below.
Also provide sufficient work space required for maintenance inspection.

 - Where the actuator receives radiant heat from strong heat sources such as heat treatment furnaces
 - Where the ambient temperature exceeds the range of 0 to 40°C
 - Where the temperature changes rapidly and condensation occurs
 - Where relative humidity smaller than 10% or larger than 85%RH
 - Where the actuator receives direct sunlight
 - Where the actuator is exposed to corrosive or combustible gases
 - Where the ambient air contains a large amount of powder dust, salt or iron (at level exceeding what is normally expected in an assembly plant)
 - Where the actuator is subject to splashed water, oil (including oil mist or cutting fluid) or chemical solutions
 - Where the actuator receives impact or vibration
 - Place with an altitude of 2,000m or more

If the actuator is used in any of the following locations, provide sufficient shielding measures:

 - Where noise generates due to static electricity, etc.
 - Where the actuator is subject to a strong electric or magnetic field
 - Where the actuator is subject to ultraviolet ray or radiation

- Storage • Preservation Environment**
 - The storage and preservation environment should comply with the same standards as those for the installation environment. In particular, when the machine is to be stored for a long time, pay close attention to environmental conditions so that no dew condensation forms.
 - Unless specially specified, moisture absorbency protection is not included in the package when the machine is delivered. In the case that the machine is to be stored and preserved in an environment where dew condensation is anticipated, take the condensation preventive measures from outside of the entire package, or directly after opening the package.
 - For storage and preservation temperature, the machine withstands temperatures up to 60°C for a short time, but in the case of the storage and preservation period of 1 month or more, control the temperature to 50°C or less.
 - Storage and preservation should be performed in the horizontal condition. In the case it is stored in the packaged condition, follow the posture instruction if any displayed on the package.

Names of the Parts

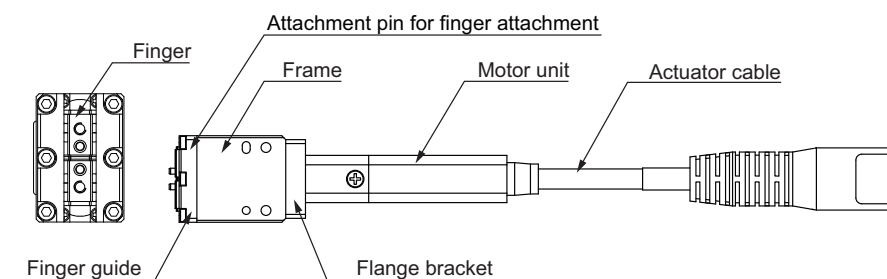

[For the details of dimensions and outlines, refer to the catalog or Instruction Manual (DVD).]

Attachment

Refer to the Instruction Manual (DVD) for the attachments of the actuator and loads.

[Precautions for Attachments]

No.	Item	Precautions
1	Attachment Surface	
2	Bolt to be used	
3	Tightening Torque	
4	Load Moment	

Wiring

For the controller, only the dedicated controller manufactured by our company can be used.
Using an undedicated controller may cause an accident such as burnout, combustion or heat generation.
Use the dedicated cable enclosed in the package when connecting the actuator and the controller.

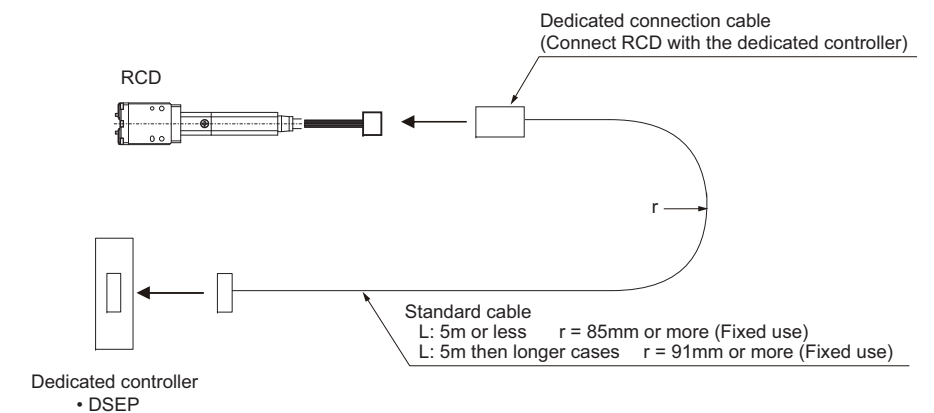

- Dedicated connection cable
- Motor-encoder cable: CB-CAN-MPA□□□

*) □□□ indicates the cable length. Up to 20m can be specified.
Example) 080 = 8m

Ensure a space for cable wiring at the back of the motor side on the actuator.
Also, make sure the cable out of the actuator is straight.

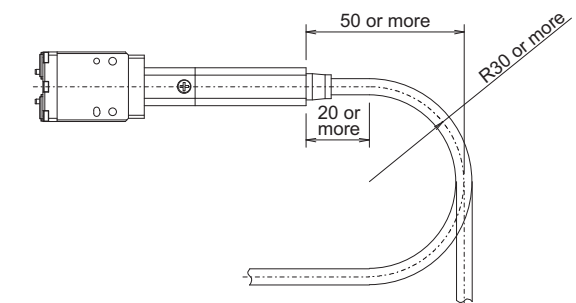

[Prohibited Items in the Cable Processing]

- Do not pull or bend forcibly the cable so as to give any extra load or tension to the cable.
- Do not process the cable to extend or shortening by means of cutting out, combination or connecting with another cable.
- Do not bend the cable in the area from the connector tip inward to 150mm on both ends.

CB-CAN-MPA□□□, CB-CAN-MPA□□□-RB

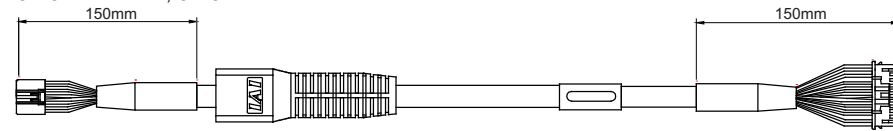

- Do not let the cable flex at a single point.

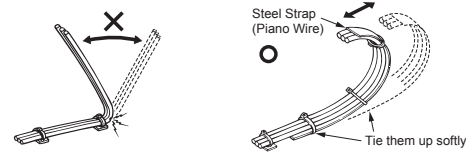

- Do not let the cable bend, kink or twist.

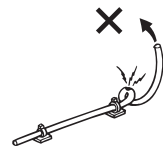

- Do not pull the cable with a strong force

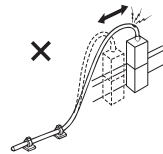

- Do not let the cable receive a turning force at a single point.

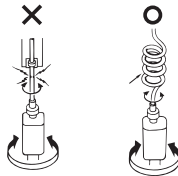

- Do not pinch, drop a heavy object onto or cut the cable.

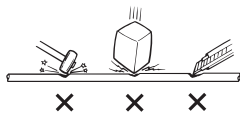

- When fixing the cable, provide a moderate slack and do not tension it too tight.

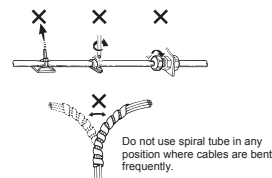

- Separate the I/O line, communication line and power line from each other. Do not store in the same duct.

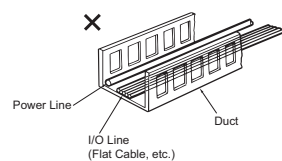

Follow the instructions below when using a cable track.

- If there is an indication to the cable for the space factor in a cable track, refer to the wiring instruction given by the supplier when storing the cable in the cable track.
- Avoid the cables to get twined or twisted in the cable track, and also to have the cables move freely and do not tie them up. (Arrange the wiring so the cables are not to be pulled when bent.) Do not pile up cables. It may cause faster abrasion of the sheaths or cable breakage.

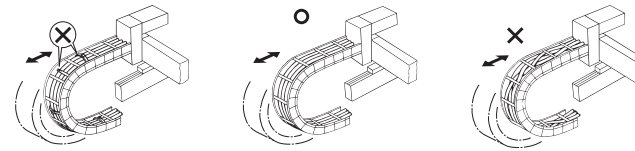

⚠ Note:

- When the cable is connected or disconnected, make sure to turn off the power to the controller. When the cable is connected or disconnected with the controller power turned ON, it might cause a malfunction of the actuator and result in a serious injury or damage to the machinery.
- When the connector connection is not correct, it would be dangerous because of a malfunction of the actuator. Make sure to confirm that the connector is connected correctly.



IAI Corporation

Head Office: 577-1 Obane Shimizu-KU Shizuoka City Shizuoka 424-0103, Japan
 TEL +81-54-364-5105 FAX +81-54-364-2589
 website: www.iai-robot.co.jp/

Technical Support available in USA, Europe and China

IAI America, Inc.

Head Office: 2690 W. 237th Street, Torrance, CA 90505
 TEL (310) 891-6015 FAX (310) 891-0815
 Chicago Office: 110 East State Parkway, Schaumburg, IL 60173
 TEL(847) 908-1400 FAX (847) 908-1399
 Atlanta Office: 1220 Kennestone Circle, Suite 108, Marietta, GA 30066
 TEL (678) 354-9470 FAX (678) 354-9471
 website: www.intelligentactuator.com

IAI Industrieroboter GmbH

Ober der Röth 4, D-65824 Schwalbach am Taunus, Germany
 TEL 06196-88950 FAX 06196-889524

IAI (Shanghai) Co., Ltd.

SHANGHAI JIAHUA BUSINESS CENTER A8-303, 808, Hongqiao Rd. Shanghai 200030, China
 TEL 021-6448-4753 FAX 021-6448-3992
 website: www.iai-robot.com

IAI Robot (Thailand) Co., Ltd.

825 PhairojKijja Tower 12th Floor, Bangna-Trad RD., Bangna, Bangkok 10260, Thailand
 TEL +66-2-361-4458 FAX +66-2-361-4456