



Quality and Innovation

# Horizontal Articulated Robot IX Series Tabletop Type, Arm Length 1000/1200 First Step Guide First Edition

Thank you for purchasing our product.  
Make sure to read the Safety Guide and detailed Operation Manual (CD or DVD) included with the product in addition to this First Step Guide to ensure correct use.  
This Operation Manual is original.

**Warning:** Operation of this equipment requires detailed installation and operation instructions which are provided on the CD or DVD Manual included in the box this device was packaged in. It should be retained with this device at all times.  
A copy of the CD or DVD Manual can be requested by contacting your nearest IAI Sales Office listed at the back cover of the Instruction Manual or on the First Step Guide.

- Using or copying all or part of this Operation Manual without permission is prohibited.
- The company names, names of products and trademarks of each company shown in the sentences are registered trademarks.

## Product Check

This product is comprised of the following parts if it is of standard configuration.  
If you find any fault in the contained model or any missing parts, contact us or our distributor.

### 1. Parts (The option is excluded.)

No.	Part Name	Model number	Quantity	Remarks
1	Robot	Refer to "How to read the model No." and "How to read the model"	1 set	
2	Dedicated Controller		1 set	
Accessories				
3	Motor • Encoder Cables		1 set	
4	D-Sub Connector with 25 Pins		1	For the 2 <sup>nd</sup> arm side user connector
5	Hood Set (D-Sub Connector with 25 Pins)		1	
6	D-Sub Connector with 37 Pins		1	For the Base side user connector
7	Hood Set (D-Sub Connector with 37 Pins)		1	
8	Hex Socket Button Head Screw M10×15		1	For the cover on tapped hole for eyebolt
9	First Step Guide		1	
10	Operation Manual (DVD)		1	
11	Safety Guide		1	

### 2. How to read the model No.

Model → **MODEL IX-NNN10040-5L-T2**  
 Serial number → **SERIAL No.000061911 MADE IN JAPAN**

### 3. How to read the model

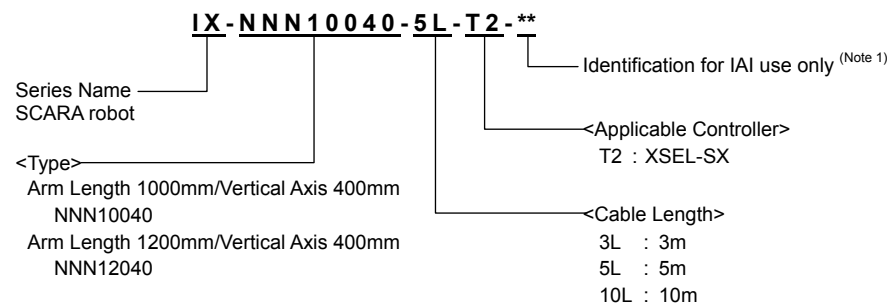

Note 1 Identification for IAI use only: This may be marked for the purpose of IAI. It is not an ID to describe the model code.

## Precautions in Handling

### 1. Handling of the Robot

Unless otherwise specified, the robot is delivered in the package was shown in the figure below. There are stoppers attached on the J1 and J2 axes.

**Notice:** Remove the stoppers before starting to operate the robot. Keep the removed stoppers, and use them to hold the robot when it is necessary to transport or carry the robot.

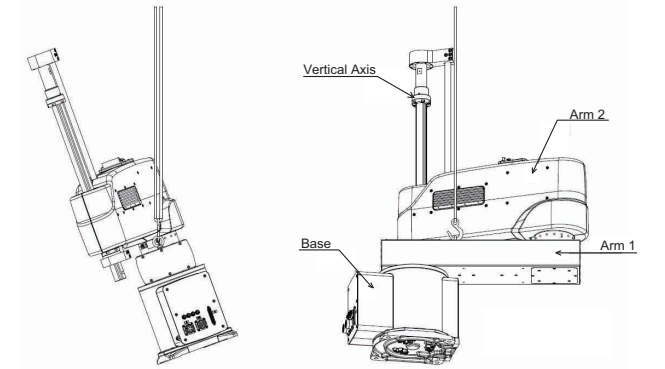
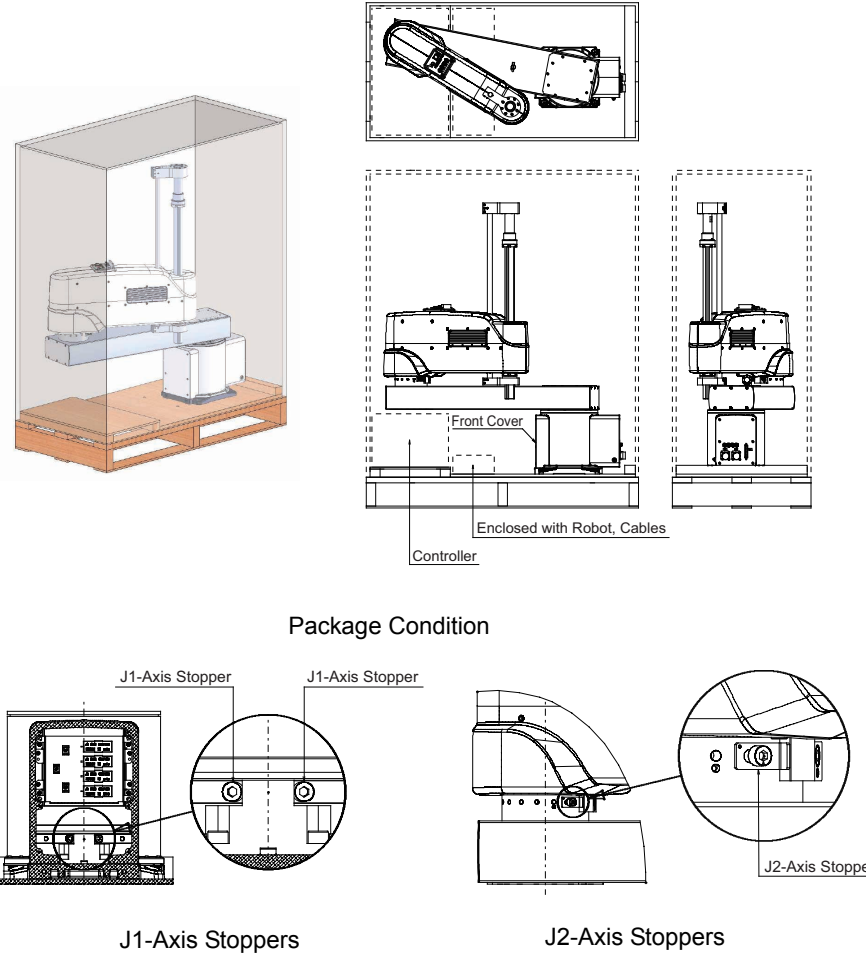

**Notice:** After the transportation work is finished, detach the eyebolts for hanging and keep them in a place you would not lose them. After removing the eyebolts, cover up the tapped holes with the (enclosed) hex socket head screws sized M10×15.

### 2. Handling of the Robot Mounted on Mechanical Equipment (System)

The following are the cautions for when transporting SCARA Robot installed in the machinery equipment (system) in the whole system.

- Transportation must be carried out with stoppers applied on J1 and J2-axes.
- When suspending the mechanical equipment (system) with ropes, avoid applying force to robot, connector, etc. Also, avoid the cables being pinched or caused an excessive deformation.

## Installation Environment, Storage Environment

### 1. Installation Environment

Do not use this product in the following environments.

Also make sure to keep enough work space necessary for maintenance.

- Location exposed to radiant heat from a huge heat source such as the heat treatment
- Location where the surrounding air temperature exceeds the range of 0 to 40°C
- Location where condensation occurs due to abrupt temperature changes
- Location where relative humidity smaller than 20% or larger than 85%RH
- Location exposed to direct sunlight
- Location exposed to corrosive gases or combustible gases
- Location exposed to significant amount of dust, salt or iron powder (Outside of an ordinary assembly plant)
- Location where water, oil (includes oil mist and cutting fluid) or a chemical is splashed
- Location where the product main body receives vibration or hit impact

When using the product in any of the locations specified below, provide a sufficient shield.

- Place subject to electrostatic noise
- Location where exposed to the influence of strong electric or magnetic field
- Location where exposed to the influence of ultraviolet or radiant rays

### 2. Storage • Preservation Environment

- The storage and preservation environment should comply with the same standards as those for the installation environment. In particular, when the machine is to be stored for a long time, pay close attention to environmental conditions so that no dew condensation forms.
- Unless specially specified, moisture absorbency protection is not included in the package when the machine is delivered. In the case that the machine is to be stored and preserved in an environment where dew condensation is anticipated, take the condensation preventive measures from outside of the entire package, or directly after opening the package.
- For storage and preservation temperature, the machine withstands temperatures up to 60°C for a short time, but in the case of the storage and preservation period of 1 month or more, control the temperature to 50°C or less.
- Storage and preservation should be performed in the horizontal condition. In the case it is stored in the packaged condition, follow the posture instruction if any displayed on the package.

### 1.1 Handling of the Carton

- Do not damage or drop. The package is not applied with any special treatment that enables it to resist an impact caused by a drop or crash.
- An operator should never attempt to carry on their own. Also, use an appropriate way for transportation.
- When placing the package, settle it horizontally following the posture instruction of the package.
- Do not step or sit on the package.
- Do not put any load that may cause a deformation or breakage of the package.

### 1.2 Handling of Robot without Package

- Carry the robot using the eyebolts to hang on a hook. When pulling up the robot, hold the 1<sup>st</sup> arm, 2<sup>nd</sup> arm or the base to keep the robot horizontal and pull it up slowly.
- When carrying a robot, it has to be done by a person who is certified for sling work and crane operation.
- Carry the robot with stoppers attached on J1 and J2 axes.
- Do not attempt to hold the vertical axis or 2<sup>nd</sup> arm for transportation.
- Do not apply too much force on each part of the robot.

## External Dimensions

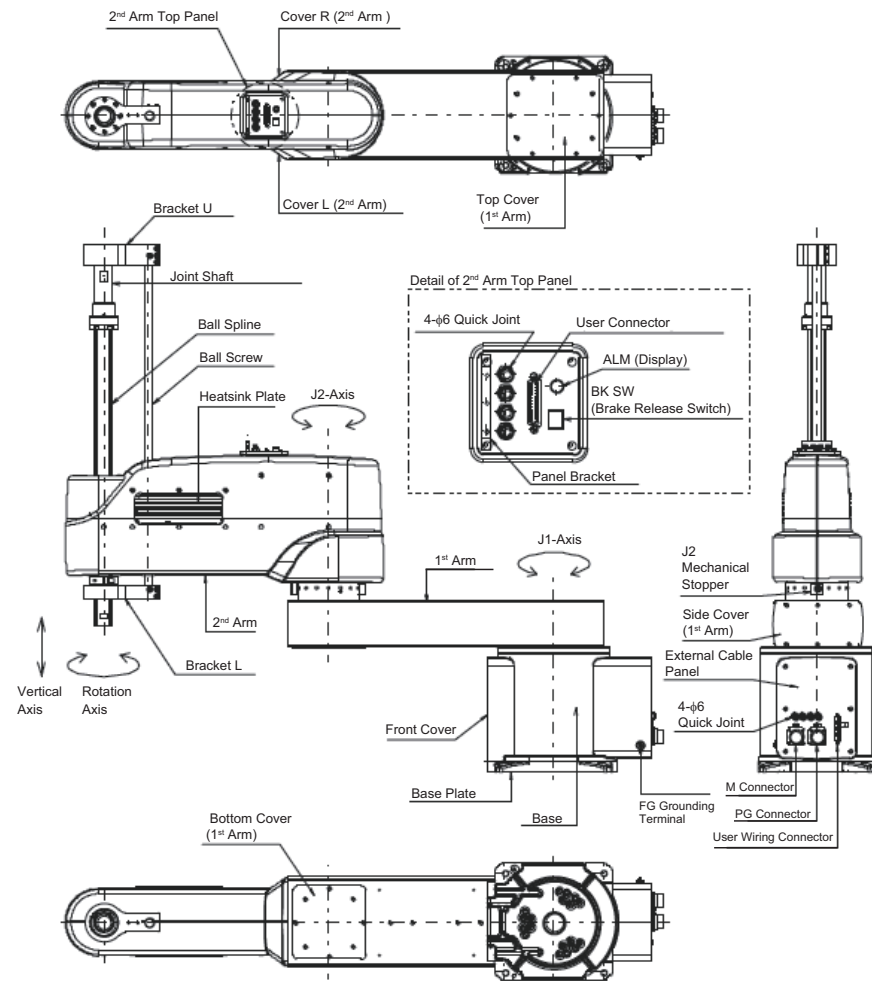

[Refer to the catalog or Operation Manual (DVD) for the detail of outline and attachments dimensions.]

## Installation

The platform on which to install the robot receives a significant reactive force. Be certain the platform has sufficient rigidity to withstand the anticipated force.

### 1. Installation Platform

- The surface on which the robot is fixed must have a thickness of 25mm or more. The levelness of the robot installation surface must be at least 0.05mm or less.
- Make a tap hole of M12 with the effective length 24mm or more on the mounting surface of the platform.
- There will be a reaction force as shown in the figure below applied to the robot during an operation. For the platform to attach the robot, consider enough strength, stiffness and stableness to endure the reaction force generated during the operations listed in the table as well as to stand the weight of the robot.

Maximum Reaction Force during Robot Operation

Model Number	Fa (Max.)		Fb (Max.)		T (Max.)	
	N	kgf	N	kgf	N	kgf
IX-NNN10040	8765	894	668	68	750	77
IX-NNN12040	7553	771	698	71	898	92

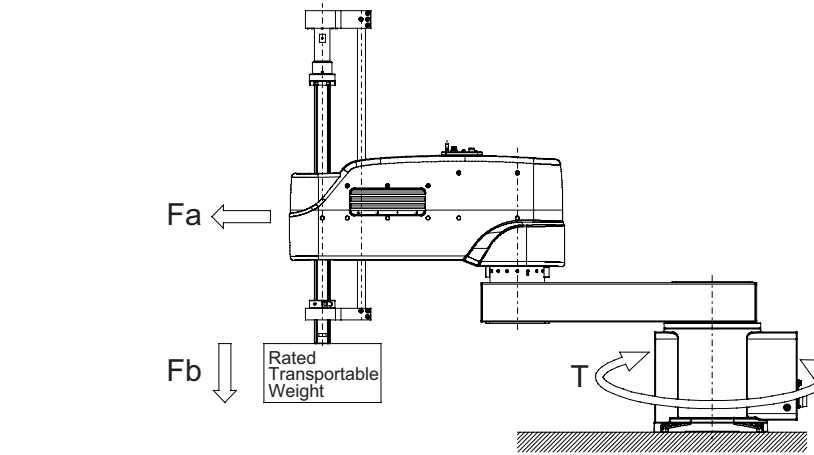

### 2. Installation of Platform

- Affix the platform on the floor to make sure it would not be moved during the robot operation.
- Install the platform to have the robot installed in horizontally.

### 3. Installation of Robot

- The robot body has to be securely fastened with using hex socket cap screws and steel ring plain washers (13 x 24 x 2.5) (4pcs each).

Attachment hole	Attachment screw	Tightening Torque
φ13.5 through φ25 Depth (Dimension from the seat to the installation surface is 8mm)	M12	104N·m

- Apply high-tensile bolts with 10.9 or more of the tensile class for the attachment bolts.

## Wiring

As the connection cable for the controller and the robot, use the IAI-dedicated controller and dedicated connection cable.

[XSEL-SX Connecting to the Controller]

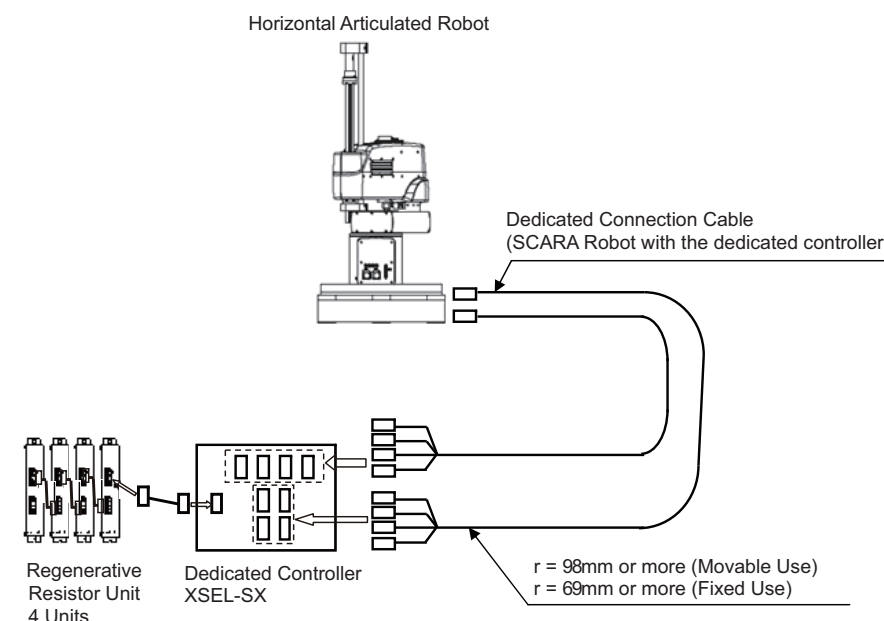

- Motor Cable CB-SX4-MA□□□
- Encoder Cable CB-SX4-PA□□□

□□□ indicates the cable length L  
Example. 030 = 3m

## Warning

- Be sure to connect to the robot of the serial number specified on the front panel of the controller. The controller will not operate properly if any other robot is connected. Failure to observe this warning may cause the robot to malfunction, resulting in a serious accident.
- Connect to the robot of the serial number specified on the robot designation label provided on the front panel of the controller.

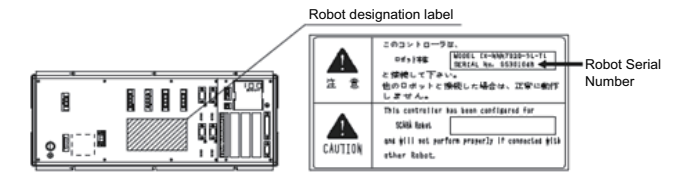

- Do not attempt to use a cable out of the dedicated cable for connection. Doing so may cause not only error operation or malfunction, but also may cause a critical accident such as fire or injury.
- When the cable is connected or disconnected, make to turn off the power to the controller. Working with the power being kept on may cause the robot to have an error operation, which may lead to a critical accident resulting in injury or death.
- When the connector connection is not correct, it would be dangerous because of a malfunction of the robot. Rigidly fix the connectors with the screws equipped to them.
- Connect the cables securely after confirming that they are free from damage or bent connector pins.
- A mistake in the connector connections may cause an error operation. Check the connector name before plugging in. Connect each cable by aligning the indication on the marking tube on the cable with the indication on the controller panel.
- When installing the PG connector (D-sub connector), ensure correct orientation of the connector.
- Since the brake power supply circuit is on the primary side (high voltage side) for the horizontal articulated robot, prepare a dedicated 24V DC power source for it. Do not attempt to use the power source for the secondary circuit such for I/O power supply in common. The brake power to be supplied to the controller should be 24V DC · 10% with the current wattage of 10W. It is necessary to increase the capacity of the brake power source when a brake-equipped actuator is connected to a controller. [Refer to the section of Power Source Capacity and Heat Generation in the instruction manual of the controller.]

Refer to the operation manuals for the controller and PC software for the procedures to connect the I/O cable, controller power cable, PC connection cable, etc.

### [Prohibited Items in the Cable Processing]

- Do not pull or bend forcibly the cable so as not to give any extra load or tension to the cable.
- Do not process the cable for extension or shortening by means of cutting out, combination or connecting with another cable.
- Have a sufficient radius for bending, and avoid a bend concentrating on one point.

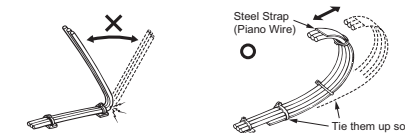

- Do not let the cable bend, kink or twist.

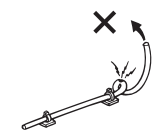

- Do not pull the cable with a strong force.

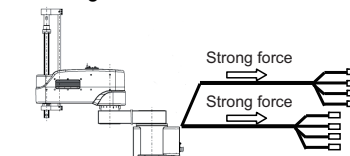

- Pay attention not to concentrate the twisting force to one point on a cable.

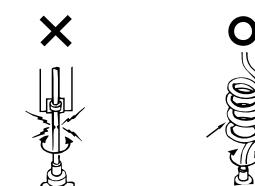

- Do not pinch, drop a heavy object onto or cut the cable.

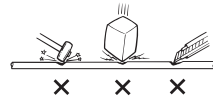

- When a cable is fastened to affix, make sure to have an appropriate force and do not tighten too much.

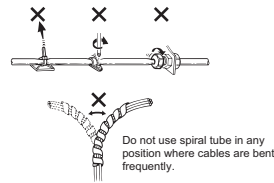

- I/O line, communication line, power and driving lines are to be put separately from each other and do not tie them together. Arrange so that such lines are independently routed in the duct.

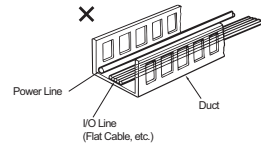

Follow the instructions below when using a cable track.

- If there is an indication to the cable for the space factor in a cable track, refer to the wiring instruction given by the supplier when storing the cable in the cable track.
- Avoid the cables to get twined or twisted in the cable track, and also to have the cables move freely and do not tie them up. (Avoid tension being applied when the cables are bent.)

Do not pile up cables. It may cause faster abrasion of the sheaths or cable breakage.

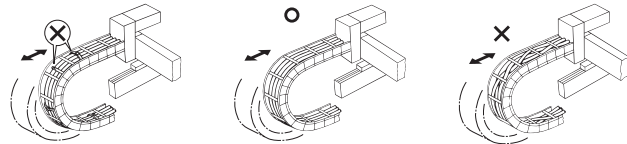

## IAI Corporation

Head Office: 577-1 Obane Shimizu-KU Shizuoka City Shizuoka 424-0103, Japan  
 TEL +81-54-364-5105 FAX +81-54-364-2589  
 website: www.iai-robot.co.jp/

Technical Support available in USA, Europe and China

## IAI America, Inc.

Head Office: 2690 W. 237th Street, Torrance, CA 90505  
 TEL (310) 891-6015 FAX (310) 891-0815  
 Chicago Office: 110 East State Parkway, Schaumburg, IL 60173  
 TEL(847) 908-1400 FAX (847) 908-1399  
 Atlanta Office: 1220 Kennestone Circle, Suite 108, Marietta, GA 30066  
 TEL (678) 354-9470 FAX (678) 354-9471  
 website: www.intelligentactuator.com

## IAI Industrieroboter GmbH

Ober der Röth 4, D-65824 Schwalbach am Taunus, Germany  
 TEL 06196-88950 FAX 06196-889524

## IAI (Shanghai) Co., Ltd.

SHANGHAI JIAHUA BUSINESS CENTER A8-303, 808, Hongqiao Rd. Shanghai 200030, China  
 TEL 021-6448-4753 FAX 021-6448-3992  
 website: www.iai-robot.com

## IAI Robot (Thailand) Co., Ltd.

825 PhairojKijja Tower 12th Floor, Bangna-Trad RD., Bangna, Bangkok 10260, Thailand  
 TEL +66-2-361-4458 FAX +66-2-361-4456