

ISDB Series Actuator

First Step Guide Second Edition

ISDB, ISPDB, ISDBCR, ISPDBCR, IS Cast SSPDACR

Thank you for purchasing our product.
Make sure to read the Safety Guide and detailed Instruction Manual (CD/DVD) included with the product in addition to this First Step Guide to ensure correct use.
This Instruction Manual is original.

Warning : Operation of this equipment requires detailed installation and operation instructions which are provided on the CD/DVD Manual included in the box this device was packaged in. It should be retained with this device at all times.
A hardcopy of the Manual can be requested by contacting your nearest IAI Sales Office listed at the back cover of the Instruction Manual or on the First Step Guide.

- Using or copying all or part of this Instruction Manual without permission is prohibited.
- The company names, names of products and trademarks of each company shown in the sentences are registered trademarks.

Product Check

This product is comprised of the following parts if it is of standard configuration.
If you find any fault in the contained model or any missing parts, contact us or our distributor.

1. Parts (The option is excluded.)

No.	Part Name	Model	Remarks
1	Main Body	Refer to "How to read the model plate", "How to read the model No."	
Accessories			
2	Motor • Encoder Cable*1		
3	Home Position Marking Sticker		
4	First Step Guide		
5	Instruction Manual (CD/DVD)		
6	Safety Guide		

*1 Please refer to [Wiring] for the applicable cables.

2. How to read the model plate

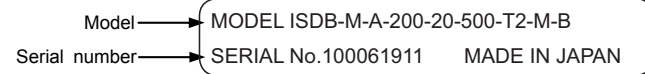

3. How to read the model No.

3.1 Simple Dust-proof Type

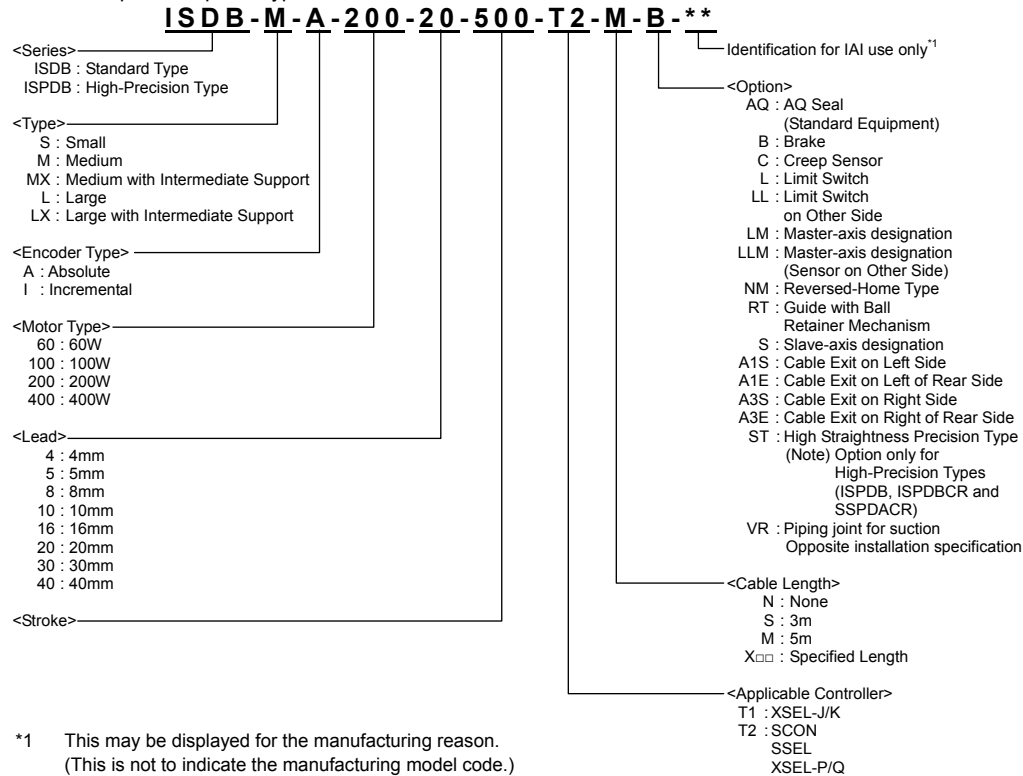

*1 This may be displayed for the manufacturing reason.
(This is not to indicate the manufacturing model code.)

3.2 Clean Room Type

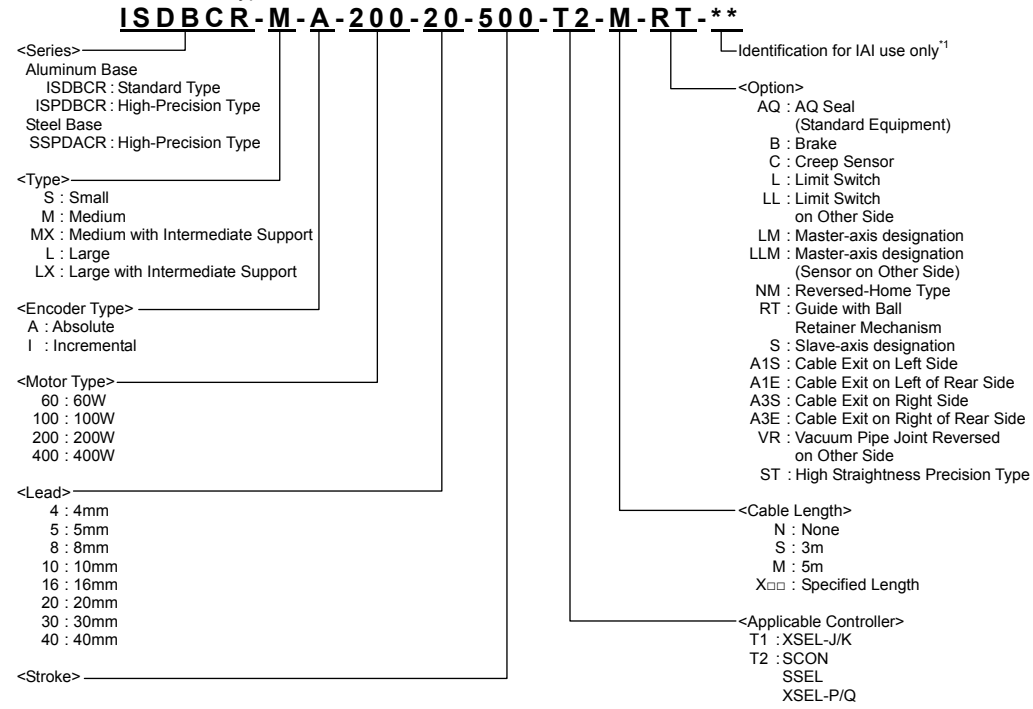

*1 This may be displayed for the manufacturing reason.
(This is not to indicate the manufacturing model code.)

Precautions in Handling

1. Handling of Robot

1.1 Handling of the Packed Product

- Unless otherwise specified, the actuator is shipped with each axis packaged separately.
- Do not damage or drop. The package is not supplied with any special treatment that enables it to resist an impact caused by a drop or crash.
 - Transport a heavy package with at least more than two operators. Consider an appropriate method for transportation.
 - If the shipping box is to be left standing or transporting, it should be in a horizontal position. Follow the instruction if there is any for the packaging condition.
 - Do not get on the package.
 - Do not put any load that may cause a deformation or breakage of the package.

1.2 Handling of Robot without Package

1.2.1 ISDB, ISPDB, ISDBCR, ISPDBCR

- Do not carry the actuator by holding the cable, or do not move it by pulling the cable.
- Hold the body base when transporting the actuator.
- When carrying the actuator, exercise caution not to bump it against nearby objects or structures.
- Do not give any excessive force to any of the sections in the actuator.
- In the case of the high-precision straightness specification type, be careful not to make a damage and the traces of hitting at the base bottom.
There is a possibility that the running accuracy changes.

1.2.2 SSPDACR

- There are 4 eyebolts attached on the unit. Use these to transport it.
The appearance of the unit is as shown below once it is unpackaged.

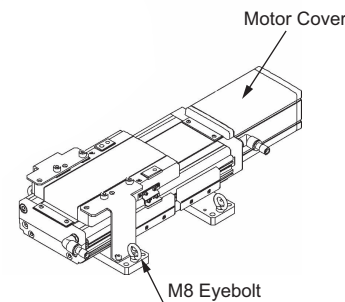

- Do not hold the motor cover when transporting the unit. Doing so may damage the motor cover with the actuator weight and the unit may drop.
The motor cover is allowed to be held only when changing the orientation of the installation and removing the metal components provided for transportation.
- Do not carry the actuator by holding the cable, or do not move it by pulling the cable.
- When carrying the actuator, exercise caution not to bump it against nearby objects or structures.
- Do not give any excessive force to any of the sections in the actuator.
- In the case of the high-precision straightness specification type, be careful not to make a damage and the traces of hitting at the base bottom.
There is a possibility that the running accuracy changes.

2. Handling of Multi-Axes Type

2.1 Handling of the Packed Product

Multi-axes type will be delivered in a package with an outer case fixed to a wooden base. Sliders are fixed so they would not accidentally move while in transportation. The end of the actuator is also fixed to avoid it swinging by external vibration.

- Do not damage or drop. The package is not supplied with any treatment that enables it to resist an impact caused by a drop or crash.
- Transport a heavy package with at least more than two operators. Consider an appropriate method for transportation.
- When suspending the package using ropes, pass the ropes from underneath the reinforcement frames at the bottom of the base. When lifting with a forklift, also place the forks underneath the base.
- Do not apply an impact on the package or let it bounce when putting it down.
- Do not get on the package.
- Do not put any load that may cause a deformation or breakage of the package.

2.2 Handling of Robot without Package

- Secure the sliders to prevent sudden movement during transport.
- If any end of the actuator is overhanging, secure it properly to avoid significant movement due to external vibration.
- If the actuator assembly is transported without the ends being secured, do not apply impact of 0.3G or more.
- In the case that the actuator needs to be carried up with ropes or another method, be sure to use an appropriate cushioning to avoid the robot being deformed or put on an excessive pressure. And also, be sure to keep the robot in a stable and horizontal posture. Utilize the tapped holes on the bottom of the base to attach a tool to suspend the package if necessary.
- Be careful not to apply a load on any of the actuator brackets or covers or on the connector box. Also, avoid the cables being pinched or caused an excessive deformation.

3. Handling of Robot Mounted on Mechanical Equipment (System)

In this section, explains how to handle the actuator when transporting it in the whole mechanical equipment (system) that the actuator is installed to.

- Secure the sliders to prevent sudden movement during transport.
- If any end of the actuator is overhanging, secure it properly to avoid significant movement due to external vibration.
- If the actuator assembly is transported without the ends being secured, do not apply impact of 0.3G or more.
- When suspending the mechanical equipment (system) with ropes, avoid applying force to actuator, connector box, etc. Also, avoid the cables being pinched or caused an excessive deformation.

Environments for Installation, Storage and Preservation

1. Installation Environment

Please attempt to avoid installing the product to such places as listed below.
It is generally the environment where a worker can work without any protection gear.
Also, make sure to keep enough space necessary for maintenance work.

- Place where exposed to radiant heat from a huge heat source such as heat treatment
- Place where the ambient temperature goes out of the applicable range from 0 to 40°C
- Place where condensation would occur due to sudden temperature change
- Place where the relative humidity exceeds 85% RH
- Place where exposed to the direct sunlight
- Place where corrosive gas or flammable gas exist
- Place where it contains a lot of dust, salt or iron (Outside of an ordinary assembly plant)
- Place where water, oil (includes oil mist and cutting fluid) or chemical is splashed
- Place where the product main body receives vibration or hit impact

Make sure to have a treatment for blocking when using in the following conditions:

- Place where noise is generated by such facts as static electricity
- Place where exposed to the influence of strong electric or magnetic field
- Place where exposed to the influence of ultraviolet or radiant rays

2. Storage and Preservation Environment

The storage and preservation environment should comply with the same standards as those for the installation environment. In particular, when the machine is to be stored for a long time, pay close attention to environmental conditions so that no dew condensation forms.

Unless specially specified, moisture absorbency protection is not included in the package when the machine is delivered. In the case that the machine is to be stored and preserved in an environment where dew condensation is anticipated, take the condensation preventive measures from outside of the entire package, or directly after opening the package.

For storage and preservation temperature, the machine withstands temperatures up to 60°C for a short time, but in the case of the storage and preservation period of 1 month or more, control the temperature to 50°C or less.

The product should be settled in the horizontal orientation while in storage and reservation. In the case it is stored in the packaged condition, follow the posture instruction if any displayed on the package.

Names of the Parts

In this First Step Guide, right side and left side are determined under the condition that the actuator is placed in horizontal posture as shown in the figure below and looking at the actuator from the motor side.

1. ISDB, ISPDB

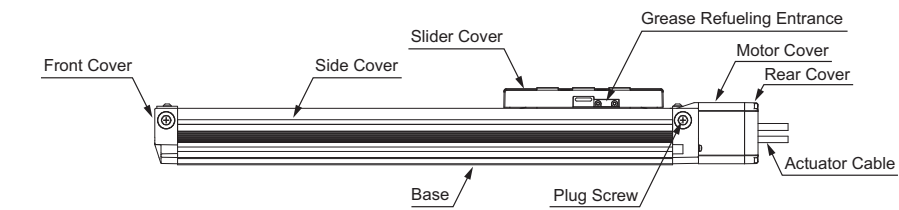
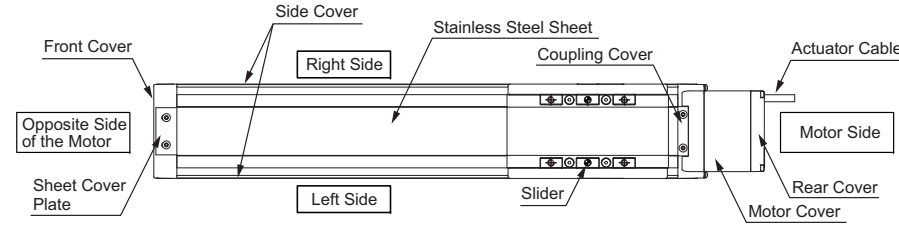

2. ISDBCR, ISPDBCR

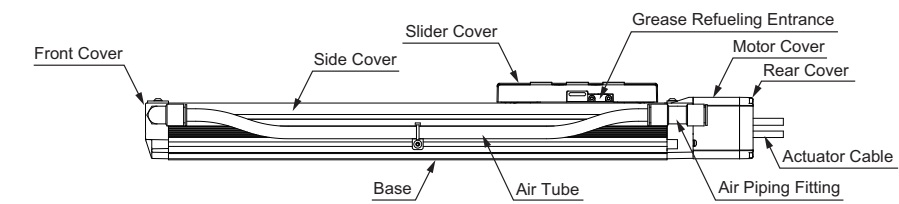
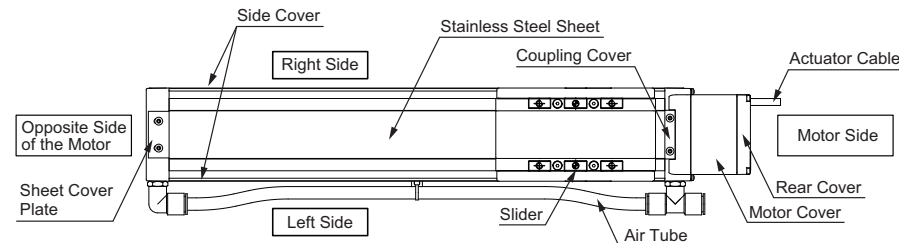

3. SSPDACR

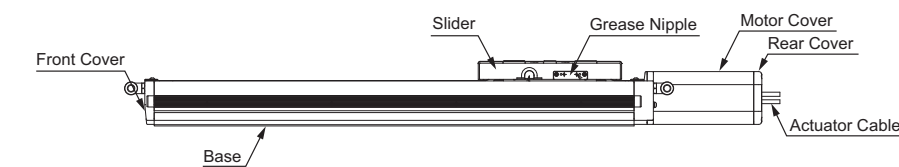
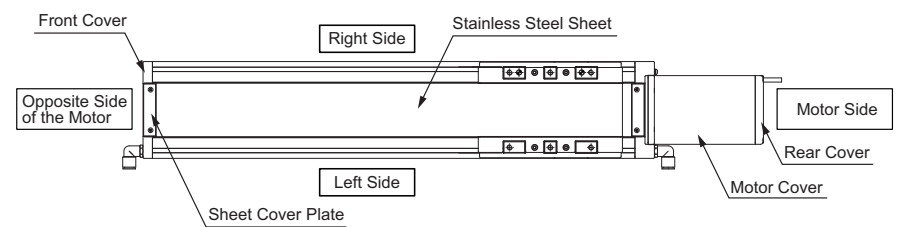

Refer to the Catalog or Instruction Manual (CD/DVD) for the dimensioned drawing and the detailed appearance drawing.

Attachment

Refer to the Instruction Manual (CD/DVD) for the attachments of the actuator and loads.

[Precautions for Attachments]

No.	Item	Precautions
1	Installation	<ul style="list-style-type: none"> For the horizontally mounted wall mount and ceiling mount of ISDB, ISPDB, ISDBCR and ISPDBCR, an adjustment of stainless steel sheet attachment is required if it is found loose in the daily maintenance inspection. The horizontally mounted wall mount or ceiling mount is basically not allowed for SSPDACR. It may cause the stainless steel sheet to be slack and off the right position, which may also cause an interference of the sheet to the work or the slider. MX and LX Types cannot be mounted in vertical position, horizontally mounted wall mount and ceiling mount. Avoid using an actuator with no brake in the vertical orientation.
2	Attachment Surface	<ul style="list-style-type: none"> The base has to have a structure with sufficient rigidity to prevent oscillation. The basis of measurement of the running accuracy of the slider is from the lower side and motor side to right side. If accuracy for its run is required, use these surfaces as a datum of the installation. In view of the motor side, the parallelism of the quasi-reference surface of left side to the reference surface is 0.1mm or less. <ul style="list-style-type: none"> The actuator mounting surface and other surfaces that are used as a datum should be flat enough with an accuracy of machining or equivalent treatment, and the flatness of the mounting surface needs to be $\pm 0.05\text{mm/m}$ or less. For High Straightness Precision Type (Model Name: ST (Option)), the actuator should be mounted on a surface that has the flatness of 0.02mm/m or less after any dirt is removed. Secure the space where maintenance work can be performed.
3	Bolts to be used	<ul style="list-style-type: none"> For the bolts to be used, a high-tensile bolt complying with ISO-10.9 or more is recommended. If using the tapped holes, use screws with the thread length dimension being less than the effective depth of the holes. In case the tapped hole is a through hole, be careful so the screw tip does not exceed the surface of the tapped hole. For the actuator mounting, use a bolt with the dimension of its effective mating length to the tapped hole size as stated below. If tapped hole in steel \rightarrow thread length same as nominal diameter. If tapped hole in aluminum \rightarrow thread length 2 times longer than nominal diameter. When using a base for installation to a platform or equivalent, in order to protect the foot base, apply washers dedicated for high-tensile bolt if using bolts of M8 or larger. No washer is needed for M6 or smaller bolts. Also, do not use a normal washer.
4	Tightening Torque	<ul style="list-style-type: none"> Please follow the specification values stated in the Instruction Manual (CD/DVD) for the tightening torque. Failure to do so may cause an operation problem.
5	Load Moment and Overhung length	<ul style="list-style-type: none"> Please follow the specification values stated in the Instruction Manual (CD/DVD) for the load moment and the overhung length. Failure to do so may cause abnormal vibration or noise, and also may remarkably shorten the product life.

Wiring

For the controller, only the dedicated controller manufactured by our company can be used. For the connection between the actuator and controller, use the attached dedicated connection cable.

[Connection to the X-SEL J/K controller]

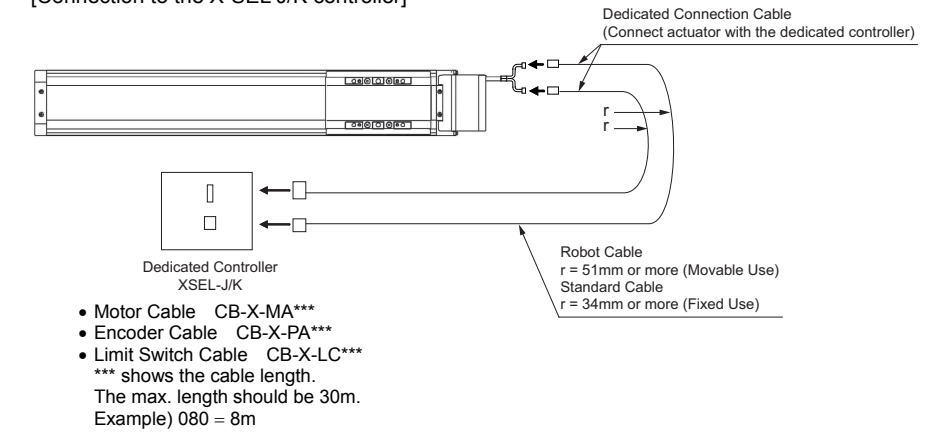

[Connection to the XSEL-P/Q, SSEL and SCON controller]

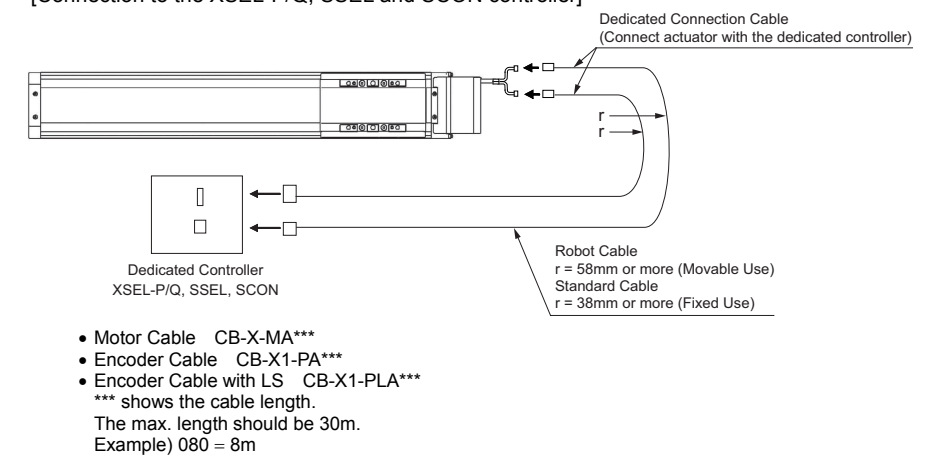

[Prohibited Items in the Cable Processing]

- Do not pull or bend forcibly the cable so as not to give any extra load or tension to the cable.
- Do not process the cable to extend or shortening by means of cutting out, combination or connecting with another cable.
- Do not let the cable flex at a single point.

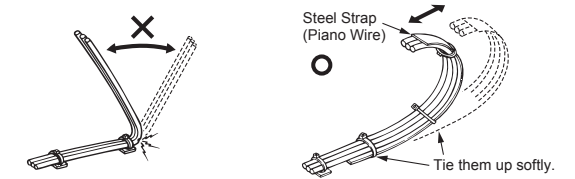

- Do not let the cable bend, kink or twist.

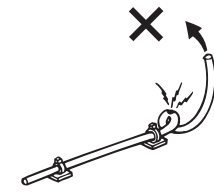

- Do not pull the cable with a strong force.

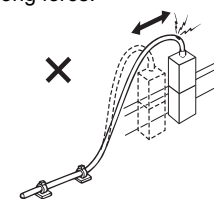

- Do not let the cable receive a turning force at a single point.

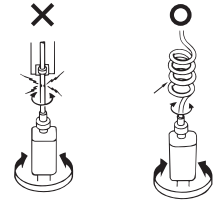

- Do not pinch, drop a heavy object onto or cut the cable.

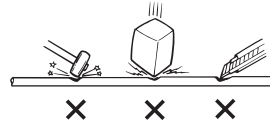

- When fixing the cable, provide a moderate slack and do not tension it too tight.

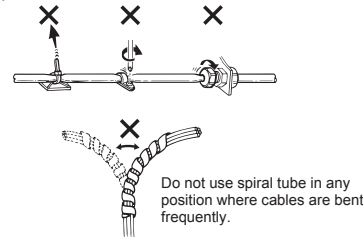

- Separate the I/O line, communication line and power line from each other. Do not store in the same duct.

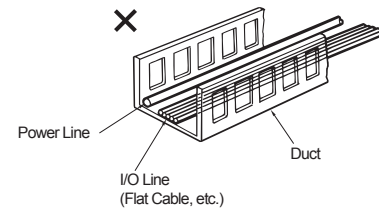

- When using a cable track, make sure to apply robot cables, avoid any tangle or twist in the cable track or flexible tube, and do not tie together so the cables are free to move. (Do not bend it at an angle of 90° or less)

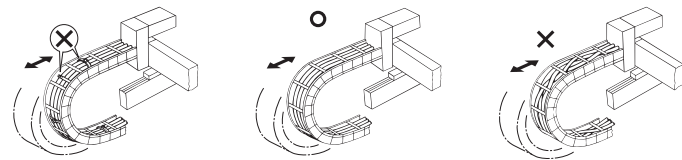

- The cable track capacity for cables to put in should be 60% or less to prevent cables from breaking. (Cable heat is not considered.)

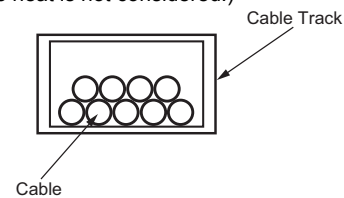

Note:

- When the cable is connected or disconnected, make sure to turn off the power to the controller. When the cable is connected or disconnected with the controller power turned ON, it might cause a malfunction of the actuator and result in a serious injury or damage to the machinery.
- When the connector connection is not correct, it would be dangerous because of a malfunction of the actuator. Make sure to confirm that the connector is connected correctly.



IAI Corporation

Head Office: 577-1 Obane Shimizu-KU Shizuoka City Shizuoka 424-0103, Japan
 TEL +81-54-364-5105 FAX +81-54-364-2589
 website: www.iai-robot.co.jp/

Technical Support available in USA, Europe and China

IAI America, Inc.

Head Office: 2690 W. 237th Street, Torrance, CA 90505
 TEL (310) 891-6015 FAX (310) 891-0815
 Chicago Office: 110 East State Parkway, Schaumburg, IL 60173
 TEL (847) 908-1400 FAX (847) 908-1399
 Atlanta Office: 1220 Kennestone Circle, Suite 108, Marietta, GA 30066
 TEL (678) 354-9470 FAX (678) 354-9471
 website: www.intelligentactuator.com

IAI Industrieroboter GmbH

Ober der Röth 4, D-65824 Schwalbach am Taunus, Germany
 TEL 06196-88950 FAX 06196-889524

IAI (Shanghai) Co., Ltd.

SHANGHAI JIAHUA BUSINESS CENTER A8-303, 808, Hongqiao Rd. Shanghai 200030, China
 TEL 021-6448-4753 FAX 021-6448-3992
 website: www.iai-robot.com

IAI Robot (Thailand) Co., Ltd.

825 PhairojKijja Tower 12th Floor, Bangna-Trad RD., Bangna, Bangkok 10260, Thailand
 TEL +66-2-361-4458 FAX +66-2-361-4456