

• Specifications of CompoNet Interface

| Item | Specification |
|--|---|
| Communication System | CompoNet dedicated protocol |
| Communication Type | Remote I/O communication |
| Baud Rate | Automatically follows the master |
| Communication Cable Length | Follows CompoNet specifications |
| Slave Type | Word-Mixed Slave |
| Available Node Addresses for Setting | 0 to 63 (Setting conducted on controller parameter) |
| Number of Occupied Channels | Refer to "3.4.1 PLC Address Construction by each Operation Mode" in the Instruction Manual for ERC3 Gateway Unit. |
| Communications Cable ^(Note 1) | Round Cable (JIS C3306, VCTF2-core) Flat cable I (with no sheathed) Flat cable II (sheathed) |
| Connector (Controller Side) | XW7D-PB4-R (Manufactured by OMRON or equivalent) |

Note 1 Prepare the communication cable separately.

• Specifications of MECHATROLINK-I/II Interface

| Item | Specification |
|--|---|
| Slave Type | Intelligent I/O |
| Baud Rate | MECHATROLINK I 4Mbps MECHATROLINK II 10Mbps |
| Max. Transmittable Distance | 50m |
| Min. Distance between Stations | 0.5m |
| Number of occupied Bytes | Refer to "3.4.1 PLC Address Construction by each Operation Mode" in the Instruction Manual for ERC3 Gateway Unit. |
| Number of Connectable Slaves | MECHATROLINK I 15 stations MECHATROLINK II 30 stations (Repeater is required for connections of more than 17 stations) |
| Transmission Frequency | 1 to 8ms |
| Data Length | MECHATROLINK I 17 byte MECHATROLINK II 17/32 byte |
| Settable Node Address Range | 61 to 7F [hex.] |
| Communications Cable ^(Note 1) | Twist Pair Cable with a Shield (characteristic impedance 130Ω) |
| Connected Connector on Controller Side | DUSB-ARB82-T11A-FA (Manufactured by DDK or equivalent) |

Note 1 Prepare the communication cable separately.

• Specifications of EtherNet/IP Interface

| Item | Specification |
|--|---|
| Communication Protocol | IEC61158 (IEEE802.3) |
| Baud Rate | 10BASE-T/100BASE-T (Autonegotiation setting is recommended) |
| Communication Cable Length | Follows EtherNet/IP specifications (Distance between hub and each node: 100m max.) |
| Number of Connection | Master Unit |
| Available Node Addresses for Setting | 0.0.0.0 to 255.255.255.255 |
| Communications Cable ^(Note 1) | Category 5e or more (Double shielded cable braided with aluminum foil recommended) |
| Connector | RJ45 Connector × 1pc |

Note 1 Prepare a LAN cable separately for the communication cable.

• Specifications of EtherCAT Interface

| Item | Specification |
|--|---|
| Communication Protocol | IEC61158 type 12 |
| Physical Layer | 100Base-TX (IEEE802.3) |
| Baud Rate | Automatically follows the master |
| Communication Cable Length | Follows EtherCAT® specifications (Distance between each node: 100m max.) |
| Slave Type | I/O slave |
| Available Node Addresses for Setting | 0 to 127 (17 to 80: When connected to the master (CJ1W-NC*82) manufactured by OMRON) |
| Communications Cable ^(Note 1) | Category 5e or more (Double shielded cable braided with aluminum foil recommended) |
| Connector | RJ45 Connector × 2pcs (Input × 1, Output × 1) |
| Connect | Daisy chain only |

Note 1 Prepare a LAN cable separately for the communication cable.

External Dimensions

Gateway Unit Main Body

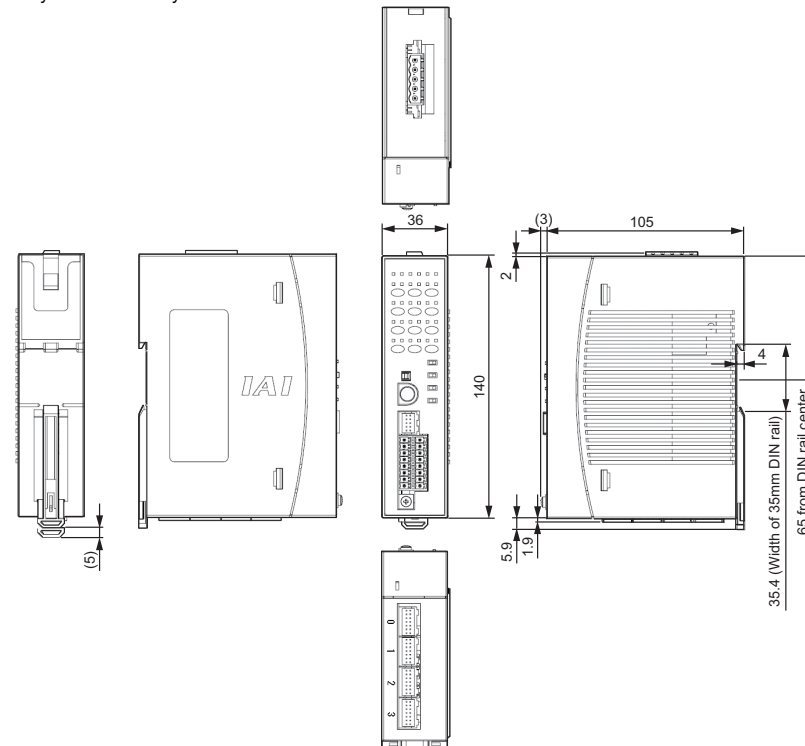

Installation Environment

This product is capable for use in the environment of pollution degree 2¹ or equivalent.

*1 Pollution Degree 2 : Environment that may cause non-conductive pollution or transient conductive pollution by frost (IEC60664-1).

1. Installation Environment

Do not use this product in the following environment.

- Location where the surrounding air temperature exceeds the range of 0 to 40°C
- Location where condensation occurs due to abrupt temperature changes
- Location where relative humidity exceeds 85%RH
- Location exposed to corrosive gases or combustible gases
- Location exposed to significant amount of dust, salt or iron powder
- Location subject to direct vibration or impact
- Location exposed to direct sunlight
- Location where the product may come in contact with water, oil or chemical droplets
- Environment that blocks the air vent [Refer to 1.7 Noise Elimination and Mounting Method]

When using the product in any of the locations specified below, provide a sufficient shield.

- Location subject to electrostatic noise
- Location where high electrical or magnetic field is present
- Location with the mains or power lines passing nearby

2. Storage and Preservation Environment

- Storage and preservation environment follows the installation environment. Especially in a long-term storage, consider to avoid condensation of surrounding air. Unless specially specified, moisture absorbency protection is not included in the package when the machine is delivered. In the case that the machine is to be stored in an environment where dew condensation is anticipated, take the condensation preventive measures from outside of the entire package, or directly after opening the package.

Installation and Noise Elimination

1. Noise Elimination Grounding (Frame Ground)

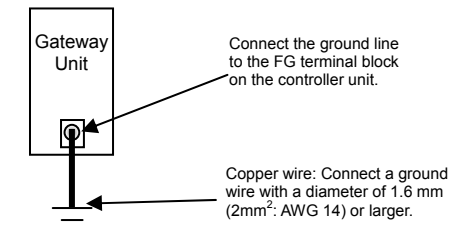

Earth Terminal
Class D grounding (Formerly Class-III grounding :
Grounding resistance at 100Ω or less)

2. Precautions regarding wiring method

- 1) Wire is to be twisted for the 24V DC power supply.
- 2) Separate the signal and encoder lines from the power supply and power lines.

3. Noise Sources and Elimination

Carry out noise elimination measures for electrical devices on the same power path and in the same equipment.

- The following are examples of measures to eliminate noise sources.
- 1) AC solenoid valves, magnet switches and relays
[Measure] Install a Surge absorber parallel with the coil.
 - 2) DC solenoid valves, magnet switches and relays
[Measure] Mount the windings and diodes in parallel. Select a diode built-in type for the DC relay.

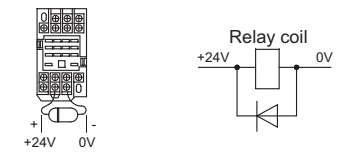
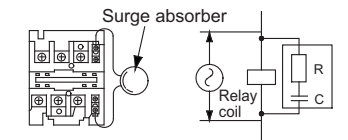
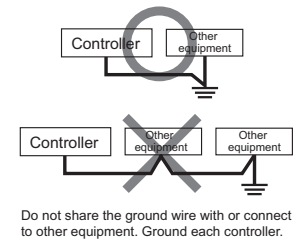

4. Cooling Factors and Installation

Design and Build the system considering the size of the controller box, location of the Gateway Unit and cooling factors to keep the ambient temperature around the Gateway Unit below 40°C. Pay a special attention to the battery unit since the performance of it would drop both in the low and high temperatures. Keep it in an environment in the room temperature as much as possible. (Approximately 20°C is the recommended temperature.)

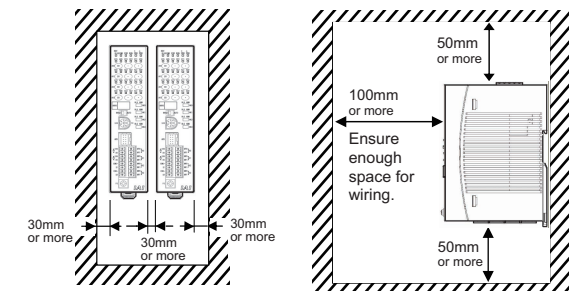

For the Gateway attachment, affix it on the DIN rail.

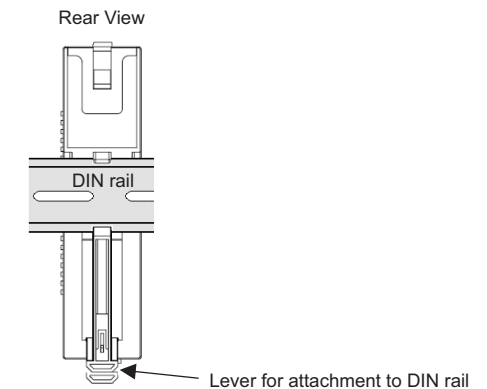

Operation Pattern Selected

There are five patterns of control methods. Set the most suitable operation pattern for your use with Gateway Parameter Setting Tool.

• Operation Patterns for PIO Type

| Operation Pattern | Description | Overview |
|-----------------------------------|---|--|
| Positioner 1 | In Positioner 1 Mode, 512 points of position data can be registered at the maximum and is able to stop at the registered positions. Monitoring of the current position is also available. | <p>PLC Target Position No. Control Signal Current Position Completion Position No. Status Signal</p> |
| Simple Direct Mode | In Simple Direct Mode, the target position can be indicated directly by inputting a value. Monitoring of the current position is also available. | <p>PLC Target Position No. Control Signal Current Position Completion Position No. Status Signal</p> |
| Direct Numeric Specification Mode | The target position, speed acceleration/deceleration and pressing current limit can be indicated with inputting a number. Monitoring of not only the current position, but also the current speed and indicated current are available. | <p>PLC Target Position Positioning Width Speed Acceleration/Deceleration Push % Control Signal Current Position Current Value (Command Value) Current Speed (Command Value) Alarm Code Status Signal</p> |
| Positioner 2 Mode | This is the operation mode of the position data of 512 points at maximum set in the position table. The monitoring of the current position is not available. This mode is that the transferred data is reduced from Positioner 1 Mode. | <p>PLC Target Position No. Control Signal Completion Position No. Status Signal</p> |
| Positioner 3 Mode | This is the operation mode of the position data of 256 points at maximum set in the position table. The monitoring of the current position is not available. This is the mode to control with the minimized number of signals to perform the positioning operation by reducing the amount of sent and received data from Positioner 2 Mode. | <p>PLC Target Position Control Signal Completion Position No. Status Signal</p> |
| I/O | 6 types (Note) of control same as for PIO (CON Mode) are available. Note They can be switched around in PIO patterns on ERC3 unit 2 types (Note) of control same as for PIO (MEC Mode) are available. Note They can be switched around in operation patterns on ERC3 unit | <p>Refer to ERC3 Actuator with Integrated Controller Instruction Manual</p> |

Wiring

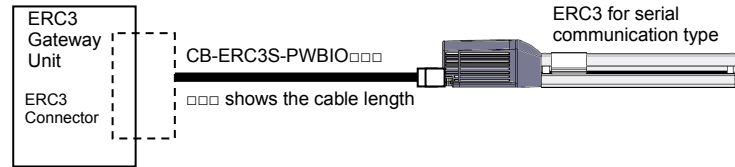
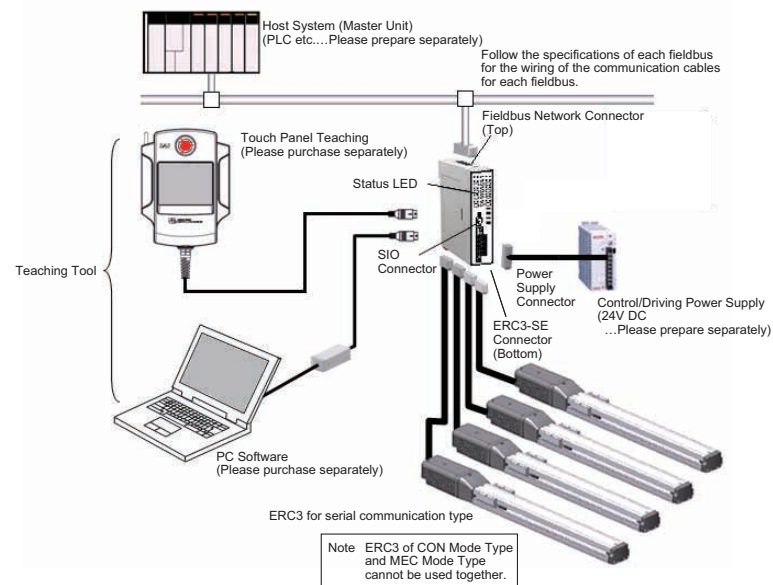

Power Supply and Emergency Stop Circuit

The following diagram shows an example of how the emergency stop switch for the teaching pendant may be included in the emergency stop circuit you may construct. If supplying power with using a 24V DC, having it turned ON/OFF, keep the 0V connected and have the +24V supplied/cut (cut one side only).

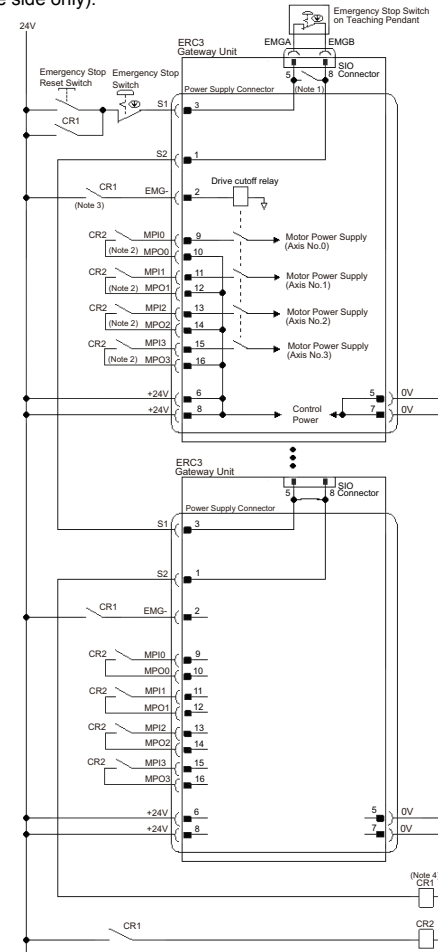

- Note 1 When the teaching pendant is not connected, S1 and S2 become short-circuited inside the controller.
 Note 2 When the motor driving source is cut off externally for a compliance with the safety category, connect a contact such as a contactor to the wires between MPI* and MPO*.
 Note 3 The rating for the emergency stop signal (EMG-) to turn ON/OFF at contact CR1 is 24V DC and 10mA.
 Note 4 For CR1, select the one with coil current 0.1A or less.

DeviceNet Type

Refer to the instruction manuals for Field Network master unit and mounted PLC for the details.

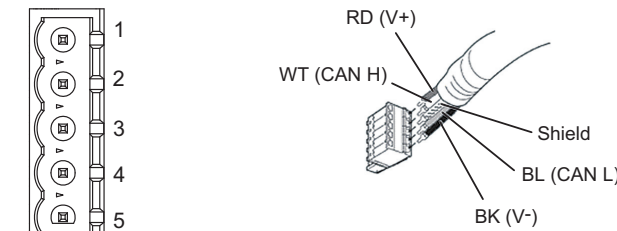

| Connector Name | DeviceNet Connector | |
|-----------------|----------------------|--|
| Cable Side | SMSTB2.5/5-ST-5.08AU | Enclosed in standard package Manufactured by PHOENIX CONTACT |
| Controller Side | MSTBA2.5/5-G-5.08AU | |

| Pin No. | Signal Name (Color) | Description | Applicable cable diameter |
|---------|---------------------|----------------------------------|-------------------------------|
| 1 | V- (BK) | Power Supply Cable Negative Side | Dedicated cable for DeviceNet |
| 2 | CAN L (BL) | Communication Data Low Side | |
| 3 | Shield (None) | Shield | |
| 4 | CAN H (WT) | Communication Data High Side | |
| 5 | V+ (RD) | Power Supply Cable Positive Side | |

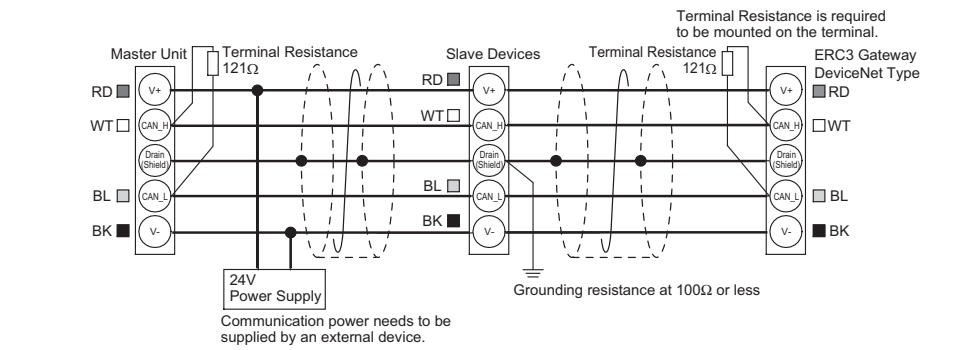

CC-Link Type

Refer to the instruction manuals for Field Network master unit and mounted PLC for the details.

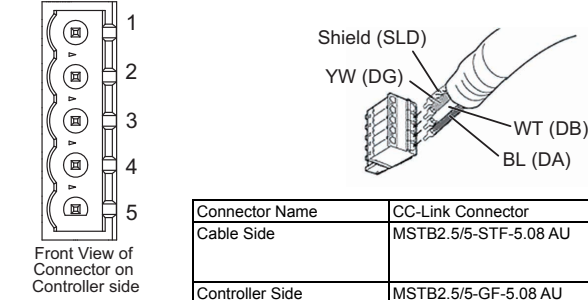

| Connector Name | CC-Link Connector | |
|-----------------|-----------------------|--|
| Cable Side | MSTB2.5/5-STF-5.08 AU | Enclosed in standard package Manufactured by PHOENIX CONTACT |
| Controller Side | MSTB2.5/5-GF-5.08 AU | |

| Pin No. | Signal Name (Color) | Description | Applicable cable diameter |
|---------|---------------------|--|-----------------------------|
| 1 | DA (BL) | Communication Line A | Dedicated cable for CC-Link |
| 2 | DB (WT) | Communication Line B | |
| 3 | DG (YW) | Digital GND | |
| 4 | SLD | Connect the shield of the shielded cable (Connect the FG of the 5 pins and controller FG internally) | |
| 5 | FG | Frame Ground (Connect the SLD of the 4 pins and controller FG internally) | |

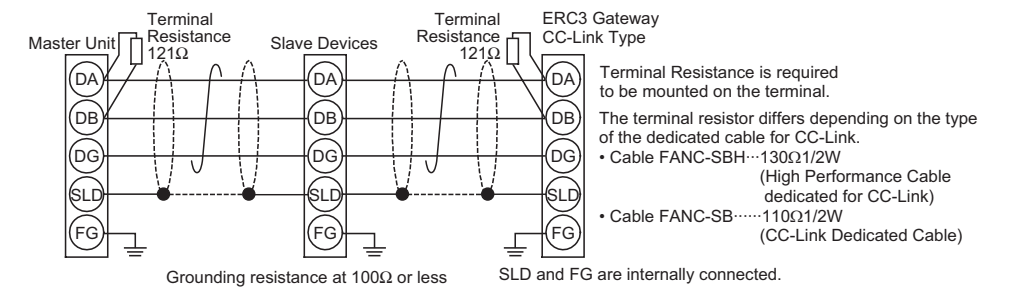

PROFIBUS-DP Type

Refer to the instruction manuals for each Field Network master unit and mounted PLC for the details.

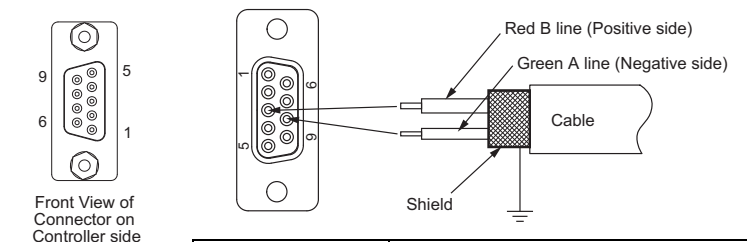

| Connector Name | PROFIBUS-DP Connector | |
|-----------------|--------------------------------|---------------------------|
| Cable Side | 9-pin D-sub Connector (Male) | Please prepare separately |
| Controller Side | 9-pin D-sub Connector (Female) | |

| Pin No. | Signal Name | Description | Applicable cable diameter |
|---------|-------------|------------------------------|-----------------------------|
| 1 | NC | Disconnected | PROFIBUS-DP Dedicated Cable |
| 2 | NC | Disconnected | |
| 3 | B-Line | Communication Line B (RS485) | |
| 4 | RTS | Request for Sending | |
| 5 | GND | Signal GND (Insulation) | |
| 6 | +5V | +5V Output (Insulation) | |
| 7 | NC | Disconnected | |
| 8 | A-Line | Communication Line A (RS485) | |
| 9 | NC | Disconnected | |

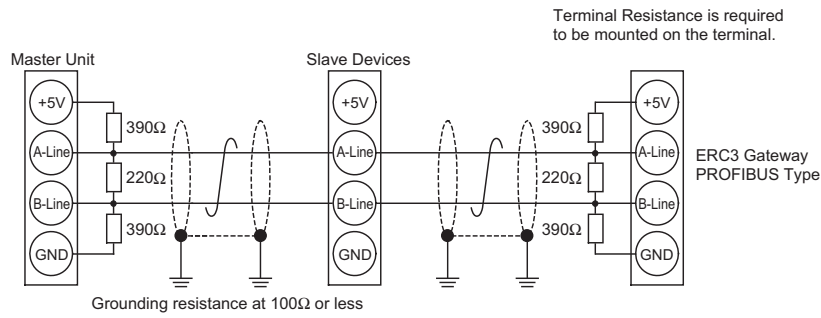

CompoNet Type

Refer to the instruction manuals for Field Network master unit and mounted PLC for the details.

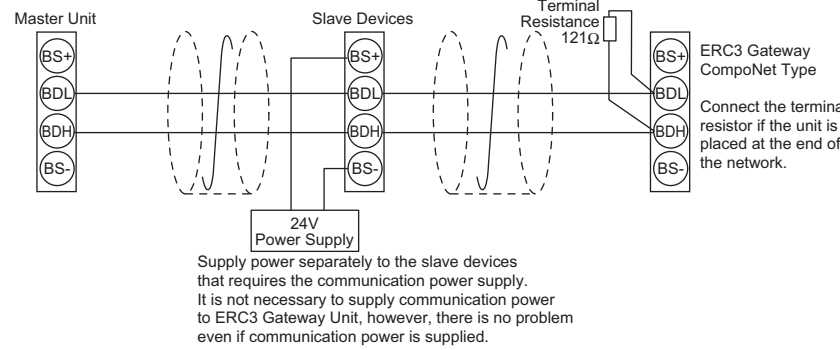
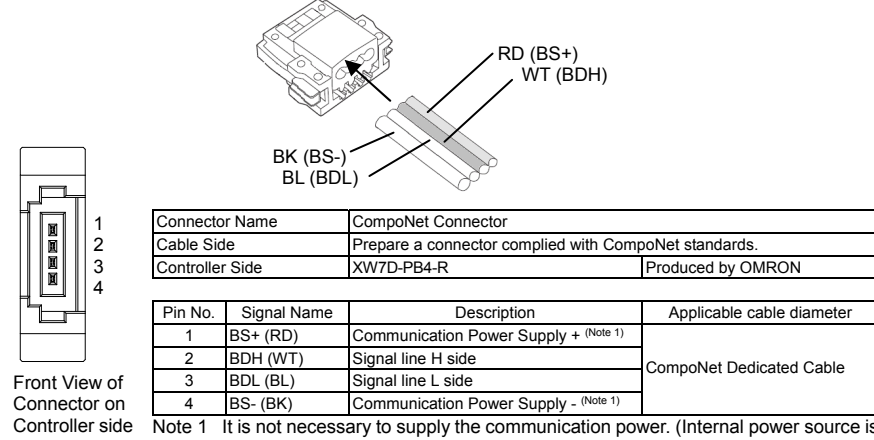

MECHATROLINK Type

Refer to the instruction manuals for Field Network master unit and mounted PLC for the details.

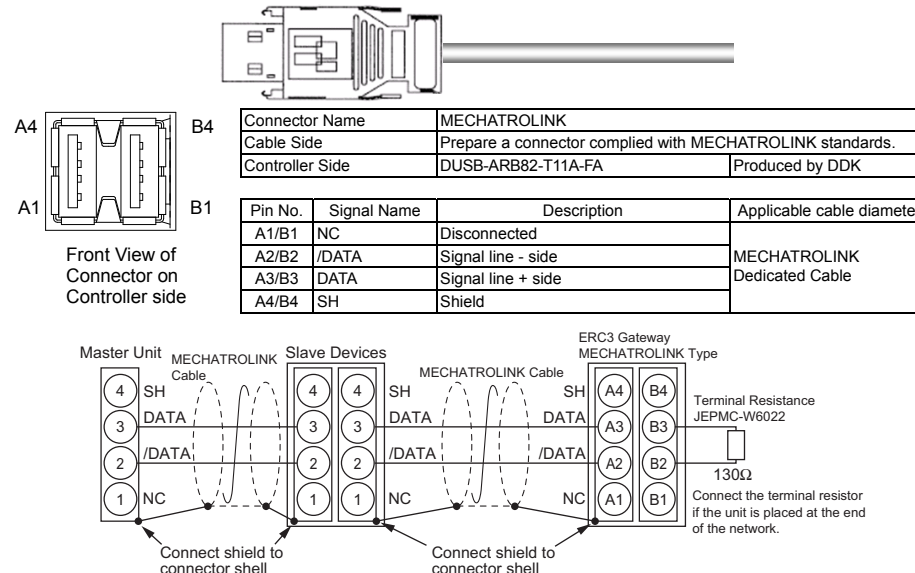

EtherNet/IP Type

Refer to the instruction manuals for Field Network master unit and mounted PLC for the details.

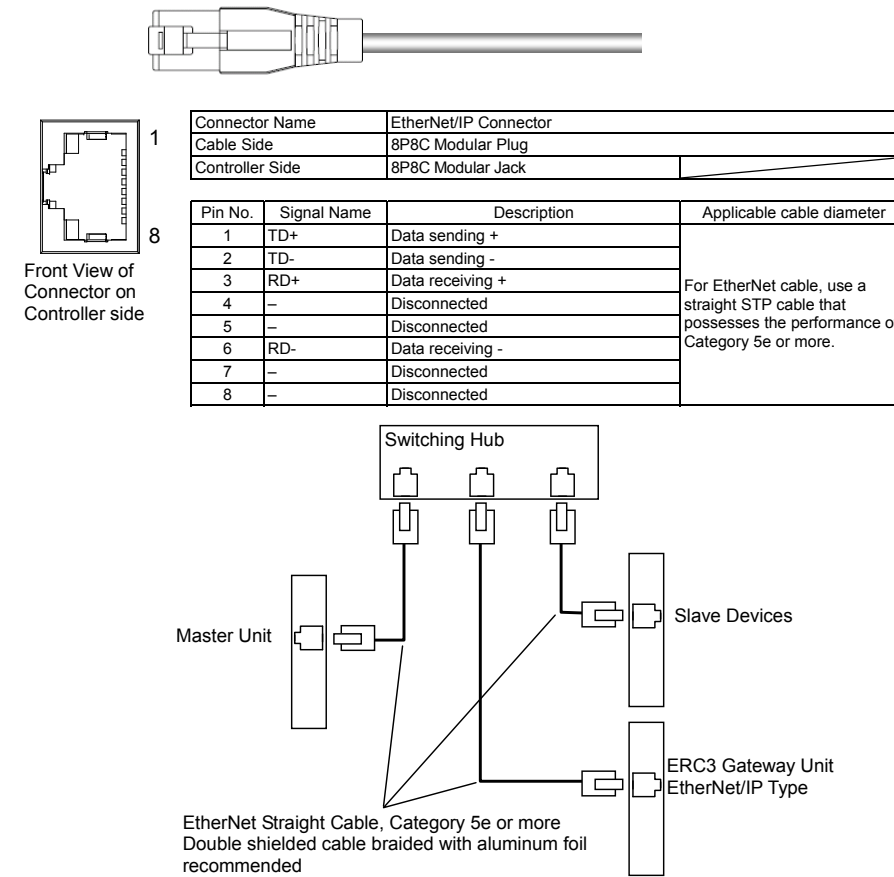

EtherCAT Type

Refer to the instruction manuals for Field Network master unit and mounted PLC for the details.

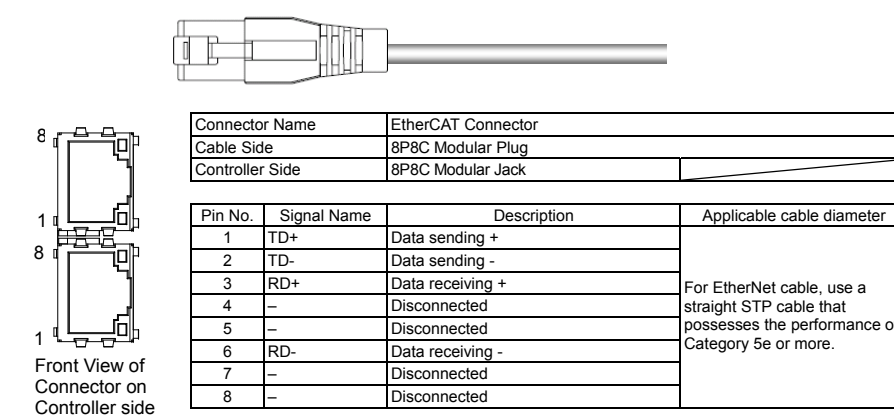

Status LED

In this product, there are some LEDs mounted to show the status of the gateway and axes. Shown below explains the layout of the LEDs and the patterns of lighting.



| Name | Color | Lamp condition | Information |
|-----------------|-------|----------------|---|
| RDY /ALM | GN | ○ | Turned ON when system is ready (after power is turned ON and CPU operating in normal condition) |
| | OR | ○ | Alarm generated |
| EMG | RD | ○ | Emergency stop |
| STATUS0 /NS/ERR | GN | - | Condition differs depending on field network [Refer to ERC3 Gateway Unit Instruction Manual for the details.] |
| | OR | - | |
| STATUS1 /MS/RUN | GN | - | Condition differs depending on field network [Refer to ERC3 Gateway Unit Instruction Manual for the details.] |
| | OR | - | |
| T.ERR | OR | × | Internal bus communication with controller in normal condition |
| | OR | ○ | Internal bus communication with controller in error |
| C.ERR | OR | × | Field network communication in normal condition |
| | OR | ○ | Field network communication in error |

• Each axis status LEDs

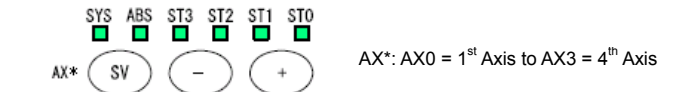

| Name | Color | Lamp condition | Information | | | |
|------|-------|---|---------------------------------|---------------------------|------|-----------------------|
| SYS | GN | ○ | Servo ON Status | | | |
| | | ☆ | Servo-motor Auto OFF condition | | | |
| | | × | Servo OFF Status | | | |
| | | ○ | Alarm generated, Emergency stop | | | |
| ABS | RD | ○ | Normal | | | |
| | | × | Not to used | | | |
| ST3 | GN | Status display | | | | |
| ST2 | GN | (i) The current command current ratio (percentage to the rating) is displayed when servo is ON. | | | | |
| ST1 | GN | (ii) Simple alarm code is displayed when an alarm is issued. | | | | |
| ST0 | GN | [Refer to ERC3 Gateway Unit Instruction Manual for the details.] | | | | |
| | | ○ Illuminating, × OFF | | | | |
| | | ST | 2 | 1 | 0 | Command Current Ratio |
| | | ALM8 | ALM4 | ALM2 | ALM1 | Simple alarm code |
| | | × | × | × | × | 0.00% to 6.24% |
| × | × | × | ○ | 6.25% to 24.99% | | |
| × | × | ○ | ○ | 25.00% to 49.99% | | |
| × | ○ | ○ | ○ | 50.00% to 74.99% | | |
| ○ | ○ | ○ | ○ | 75.00% to 100.00% or more | | |

Starting Procedures

When using this product for the first time, make sure to avoid mistakes and incorrect wiring by referring to the procedure below. "PC" stated in this section means "PC software".

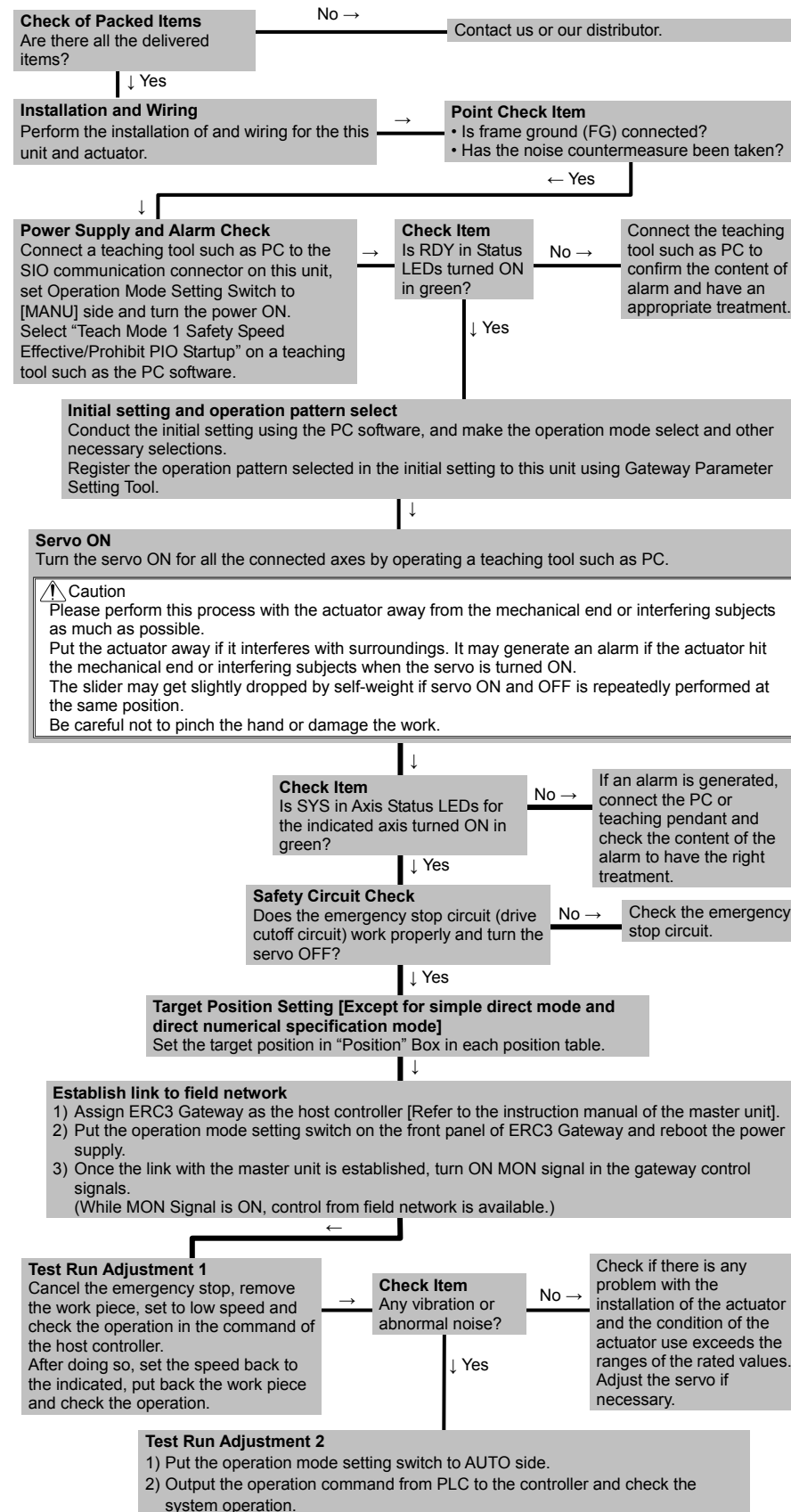

IAI Corporation

Head Office: 577-1 Obane Shimizu-KU Shizuoka City Shizuoka 424-0103, Japan
 TEL +81-54-364-5105 FAX +81-54-364-2589
 website: www.iai-robot.co.jp/

Technical Support available in USA, Europe and China

IAI America, Inc.

Head Office: 2690 W. 237th Street, Torrance, CA 90505
 TEL (310) 891-6015 FAX (310) 891-0815
 Chicago Office: 110 East State Parkway, Schaumburg, IL 60173
 TEL (847) 908-1400 FAX (847) 908-1399
 Atlanta Office: 1220 Kennestone Circle, Suite 108, Marietta, GA 30066
 TEL (678) 354-9470 FAX (678) 354-9471
 website: www.intelligentactuator.com

IAI Industrieroboter GmbH

Ober der Röth 4, D-65824 Schwalbach am Taunus, Germany
 TEL 06196-88950 FAX 06196-889524

IAI (Shanghai) Co., Ltd.

SHANGHAI JIAHUA BUSINESS CENTER A8-303, 808, Hongqiao Rd. Shanghai 200030, China
 TEL 021-6448-4753 FAX 021-6448-3992
 website: www.iai-robot.com

IAI Robot (Thailand) Co., Ltd.

825 PhairojKijja Tower 12th Floor, Bangna-Trad RD., Bangna, Bangkok 10260, Thailand
 TEL +66-2-361-4458 FAX +66-2-361-4456