

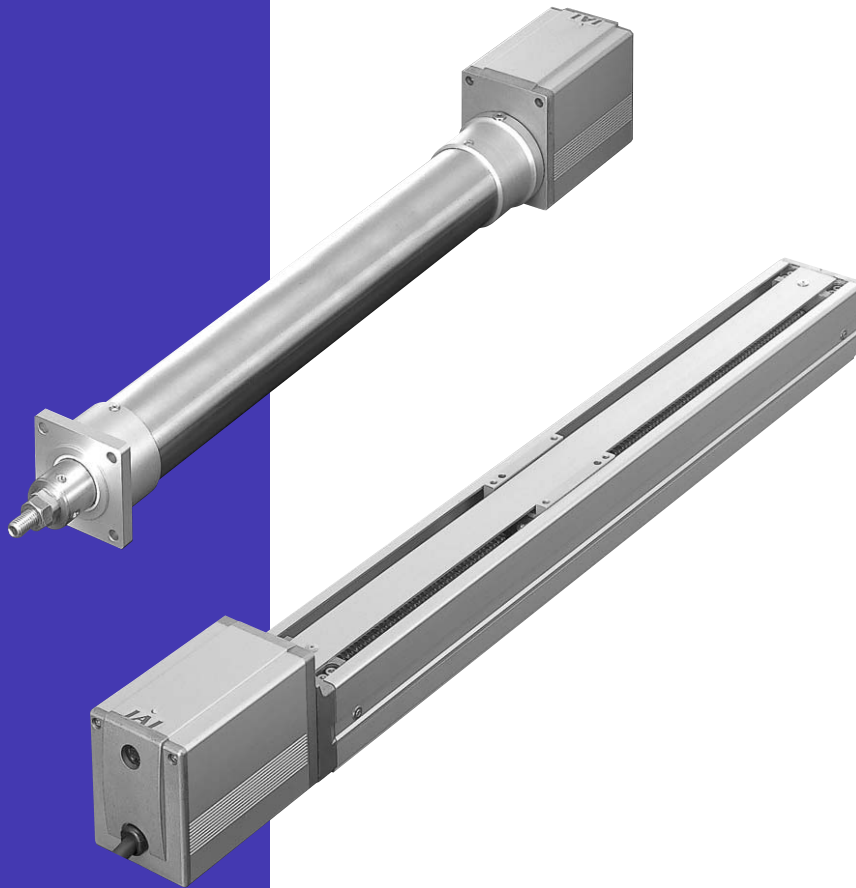

ERC Actuator with Integrated Controller

Operation Manual Seventh Edition



IAI America, Inc.

Please Read Before Use

Thank you for purchasing our product.

This Operation Manual explains the handling methods, structure and maintenance of this product, among others, providing the information you need to know to use the product safely.

Before using the product, be sure to read this manual and fully understand the contents explained herein to ensure safe use of the product.

The DVD that comes with the product contains operation manuals for IAI products.

When using the product, refer to the necessary portions of the applicable operation manual by printing them out or displaying them on a PC.

After reading the Operation Manual, keep it in a convenient place so that whoever is handling this product can reference it quickly when necessary.

[Important]

- This Operation Manual is original.
- The product cannot be operated in any way unless expressly specified in this Operation Manual. IAI shall assume no responsibility for the outcome of any operation not specified herein.
- Information contained in this Operation Manual is subject to change without notice for the purpose of product improvement.
- If you have any question or comment regarding the content of this manual, please contact the IAI sales office near you.
- Using or copying all or part of this Operation Manual without permission is prohibited.
- The company names, names of products and trademarks of each company shown in the sentences are registered trademarks.

2. Basic Parameter Settings

When the power is input for the first time, at least the two parameters specified below must be set in accordance with the intended application.

If these parameters are not set properly, the ERC will not function correctly. So, pay due attention to ensure the parameters are set properly.

For details on the setting method, refer to the “parameter settings” of the PC or teaching pendant.

[1] PIO pattern selection

This controller provides three PIO (parallel I/O) patterns to support various applications.

To select a desired PIO pattern, set a number between “0” and “2” in parameter No. 25 (PIO pattern selection).

The factory setting is “0.”

Setting of parameter No. 25	Feature of the PIO pattern
0	8 points The basic pattern providing eight positioning points.
1	3 points (air cylinder) Use of the ERC as an air cylinder is assumed in this pattern. The number of positioning points is limited to three, but a direct command input and a position complete output are provided for each target position in line with the conventional practice of air cylinder control. This lets the user control the ERC just like an air cylinder.
2	16 points The number of positioning points is increased to 16. However, the home return input is not provided.

[2] Enabling/Disabling the Pause Signal (*STP)

The pause signal uses the contact b logic to provide a failsafe function.

Therefore, this signal must remain ON in normal conditions of use.

Since there are applications where this signal is not used, a parameter is provided to disable the pause signal so it doesn't have to be turned ON.

To select a desired setting, set “0” or “1” in user parameter No. 15 (Pause input disable selection).

	Setting
Enable (use) the signal	0
Disable (do not use) the signal	1

The factory setting for this parameter is “0: [Enable].”

1. When Using Multiple 24-V Power Supplies

If multiple 24-V power supplies are used, be sure to adjust 0 V to the same level on all units. If 0 V varies among the power supplies, the controller board, SIO converter or other hardware may be damaged.

[Connection example]

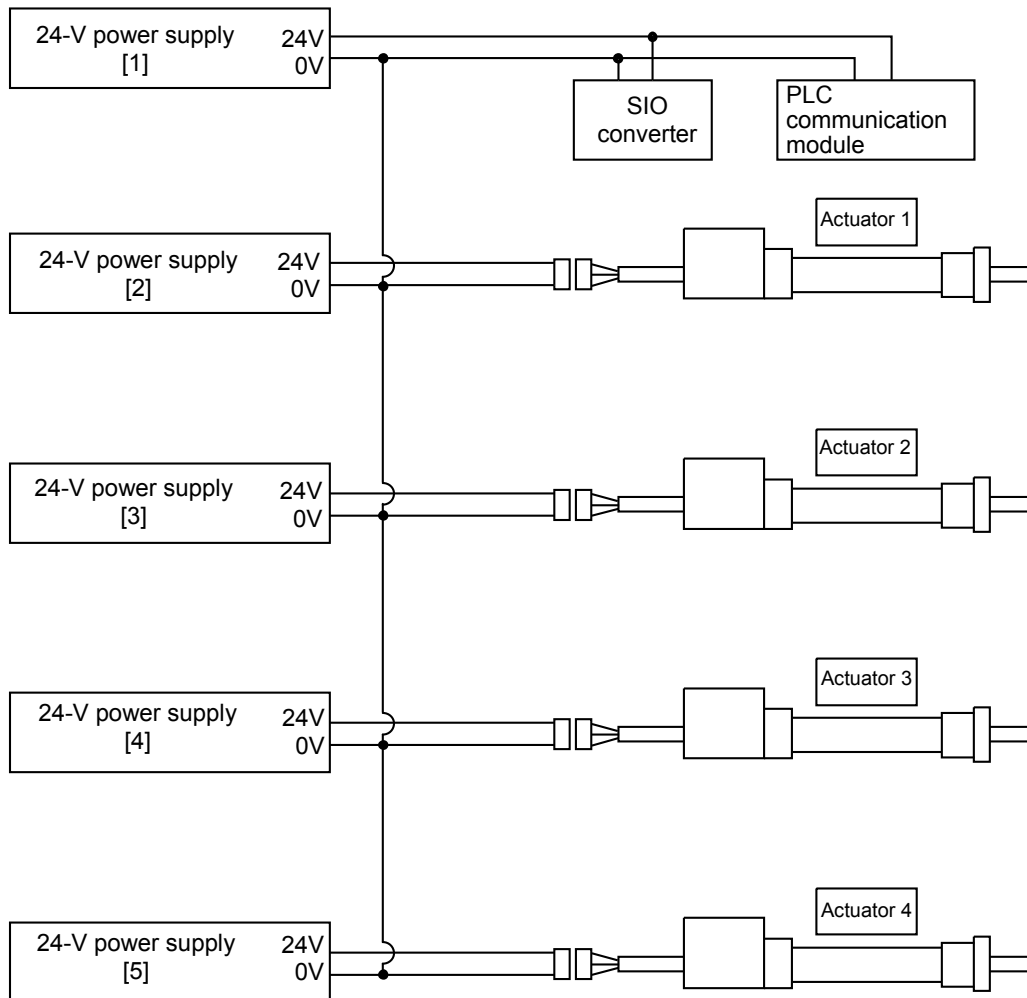

3. Recommendation for Backing up Latest Data

The controller part of this actuator uses nonvolatile memory to store the position table and parameters. Normally the memory will retain the stored data even after the power is disconnected. However, the data may be lost if the nonvolatile memory becomes faulty.

We strongly recommend that the latest position table and parameter data be backed up so that the data can be restored quickly in the event of power failure, or when the controller must be replaced for a given reason.

The data can be backed up using the following methods:

- [1] Save to a CD or FD from the PC software.
- [2] Hand write the position table and parameter table on paper.

4. Compatibility of Teaching Pendant

The existing teaching pendants of <RCA-T> and <RCA-E> types can be used with the ERC controller, but your RCA-T/RCA-E teaching pendant will require some modification.

If you are using a teaching pendant of either type, please send it to IAI. We will perform the necessary modification and return it to you as soon as possible.

Teaching pendants that have already been modified have a specific code at the end of their serial number. Please check the serial number of your teaching pendant to see if it requires modification.

Teaching pendant model	Code at the end of serial number
RCA-T	••••••• F3
RCA-E	••••••• H3
RCA-P	••••••• H3
RCB-J	••••••• B2

5. PC Software Versions

This actuator is supported by PC software version 4.0.0.0 or later.

Table of Contents

Safety Guide	1
1. Overview	1
1.1 Introduction	1
1.2 Meaning of the Model Name	2
1.3 Specifications	3
1.3.1 Correlation Diagrams of Speed and Load Capacity – Slider Type	4
1.3.2 Correlation Diagrams of Speed and Load Capacity – Rod Type	5
1.3.3 Sound Pressure Levels of This Product Will Not Exceed 70 dB.	6
1.4 Safety Precautions.....	7
1.5 Warranty Period and Scope of Warranty	8
1.6 Transportation and Handling	9
1.6.1 Handling before Unpacking.....	9
1.6.2 Handling after Unpacking.....	9
1.7 Installation Environment and Noise Elimination	10
1.7.1 Installation Environment.....	10
1.7.2 Storage Environment	10
1.7.3 Power Supply	11
1.7.4 Noise Elimination	11
1.8 Cabling.....	13
2. Installation.....	16
2.1 Name of Each Part	16
2.1.1 Slider Type (SA6/SA7)	16
2.1.2 Rod Type (RA54/RA64)	16
2.1.3 (1) Rod Type with a Single Guide (RA54GS/RA64GS)	17
(2) Rod Type with Double Guides (RA54GD/RA64GD).....	17
2.2 Installation.....	18
2.2.1 Slider Type	18
● Installing the actuator	18
2.2.2 Rod Type.....	19
● Affixing with a flange.....	19
● Affixing through holes in a flange	19
● Affixing with foot brackets (optional).....	20
2.2.3 Installing the Load	21
● Slider Type.....	21
● Rod Type	22
● Rod type with a guide(s).....	22
3. Wiring.....	23
3.1 Basic Structure.....	23
3.2 I/O Connections for PIO Pattern 1 [3 Points] (Air Cylinder).....	26
3.2.1 Explanation of I/O Signals.....	26
3.2.2 Details of Input Signals	27
■ Movement to each position (ST0 to ST2).....	27

■ Pause (*STP).....	27
3.2.3 Details of Output Signals	28
■ Completion of each position (PE0 to PE2).....	28
■ Alarm (*ALM)	28
3.3 I/O Connections for PIO Pattern 0 [8 Points].....	29
3.4 I/O Connections for PIO Pattern 2 [16 Points].....	29
3.4.1 Explanation of I/O Signals.....	30
3.4.2 Details of Input Signals	30
■ Start (CSTR).....	30
■ Command position number (PC1 to PC8).....	31
■ Pause (*STP).....	31
■ Home return (HOME)	31
3.4.3 Details of Output Signals	31
■ Position complete (PEND).....	31
■ Home return completion (HEND)	32
■ Zone (ZONE).....	32
■ Alarm (*ALM).....	32
3.5 Configuration Using a SIO Converter	33
3.6 Configuration Using an Insulated PIO Terminal Block.....	36
3.7 Configuration Using Both SIO Converter and Insulated PIO Terminal Block	40
3.8 Controlling Multiple Axes via Serial Communication	43
3.8.1 Basic Specifications	43
3.8.2 Address Assignment	43
3.8.3 Wiring Examples for Linking Multiple Axes	44
● Using only a SIO converter.....	44
● Using both SIO converter and insulated PIO terminal block	45
3.9 Emergency-Stop Circuit.....	46
3.10 Relay Cable	48
4. Electrical Specifications	50
4.1 Controller	50
4.2 I/O Signal Interface Circuit.....	51
4.2.1 External Input Specifications.....	51
4.2.2 External Output Specifications	52
4.3 SIO Converter (Optional).....	53
4.4 Insulated PIO Terminal Block (Optional).....	55
5. Data Entry <Basics>	61
5.1 Description of Position-Data Table.....	62
5.1.1 Relationship of Push Force at Standstill and Current-Limiting Value	66
● Slider type.....	66
(1) SA6 type.....	66
(2) SA7 type.....	66
● Rod type	67
(1) RA54 type	67
(2) RA64 type	67
5.2 Explanation of Modes	68
5.2.1 Positioning Mode Push = 0	68

5.2.2	Push & Hold Mode Push = Other than 0.....	68
5.2.3	Speed Change during Movement	70
5.2.4	Operation at Different Acceleration and Deceleration Settings	70
5.2.5	Pause	71
5.2.6	Zone Signal Output	71
5.2.7	Home Return.....	71
6.	Operation in the “3 Points (Air Cylinder)” Mode <Practical Operation>	72
6.1	Overview of the “3 Points” Mode	72
6.2	How to Start	74
6.3	Moving Operation	76
7.	Operation in the “8 Points” and “16 Points” Modes <Practical Operation> ...	80
7.1	How to Start	80
7.2	How to Execute Home Return	82
7.2.1	8 Points	82
7.2.2	16 Points	83
7.3	Home Return and Movement after Start (16 Points)	84
7.4	Positioning Mode (Back and Forth Movement between Two Points).....	86
7.5	Push & Hold Mode.....	88
7.5.1	Return Action after Push & Hold by Relative Coordinate Specification	89
7.6	Speed Change during Movement	90
7.7	Operation at Different Acceleration and Deceleration Settings	92
7.8	Pause.....	94
7.9	Zone Signal Output.....	96
7.10	Incremental Moves	98
7.11	Notes on Incremental Mode.....	100
8.	Parameters	102
8.1	Parameter Classification.....	102
8.2	Parameter Table	102
8.3	Parameter Settings.....	103
8.3.1	Parameters Relating to the Actuator Stroke Range.....	103
●	Soft limit	103
●	Zone boundary	103
●	Home return direction	104
●	Home return offset.....	104
8.3.2	Parameters Relating to the Actuator Operating Characteristics	104
●	Default speed	104
●	Default acceleration/deceleration	104
●	Default positioning band (in-position)	104
●	Default acceleration only MAX flag	105
●	Push & hold stop judgment period	105
●	Current-limiting value at standstill during positioning	105
●	Current-limiting value during home return	106
●	Excited-phase Signal Detection Direction	106
8.3.3	Parameters Relating to the External Interface.....	107
●	PIO pattern selection	107

● Movement command type	107
● Pause input disable selection	108
● Serial communication speed	108
● Minimum delay time for slave transmitter activation	108
8.3.4 Servo Gain Adjustment	109
● Servo gain number	109
9. Troubleshooting	110
9.1 Action to Be Taken upon Occurrence of Problem.....	110
9.2 Alarm Level Classification.....	110
9.3 Alarm Description and Cause/Action.....	111
(1) Message level alarms	111
(2) Operation-cancellation level alarms	112
(3) Cold-start level alarms	113
9.4 Messages Displayed during Operation Using the Teaching Pendant or PC Software.....	114
9.5 Specific Problems	116
● I/O signals cannot be exchanged with the PLC.....	116
● The LED lamp does not illuminate after the power is input.....	116
● The LED illuminates in red when the power is turned on.....	116
● Home return ends in the middle in a vertical application.....	116
● Noise occurs during downward movements in a vertical application.....	116
● Vibration occurs when the actuator is stopped.....	117
● The actuator overshoots when decelerated to a stop.....	117
● The home and target positions sometimes shift on the rod-type actuator.....	117
● The speed is slow during push & hold operation.....	117
● The actuator operates abnormally when the servo is turned on following the power on.....	117
10.Maintenance and Inspection	118
10.1 Inspection Items and Timings	118
10.2 Visual Inspection of Appearance	118
10.3 Cleaning.....	118
10.4 Internal Check (Slider Type)	119
10.5 Internal Cleaning (Slider Type)	120
10.6 Greasing the Guide (Slider Type)	120
10.7 Greasing the Ball Screw (Slider Type).....	122
10.8 Greasing the Rod Slide Surface	123
10.9 Motor Replacement Procedure.....	124
Appendix	126
Example of Basic ERC Positioning Sequence	126
Recording of Position-Data Table.....	129
Parameter Records	130
Change History	132

Safety Guide

This "Safety Guide" is intended to ensure the correct use of this product and prevent dangers and property damage. Be sure to read this section before using your product.

Regulations and Standards Governing Industrial Robots

Safety measures on mechanical devices are generally classified into four categories under the International Industrial Standard ISO/DIS 12100, "Safety of machinery," as follows:

- Safety measures
 - Inherent safety design
 - Protective guards --- Safety fence, etc.
 - Additional safety measures --- Emergency stop device, etc.
 - Information on use --- Danger sign, warnings, operation manual

Based on this classification, various standards are established in a hierarchical manner under the International Standards ISO/IEC. The safety standards that apply to industrial robots are as follows:

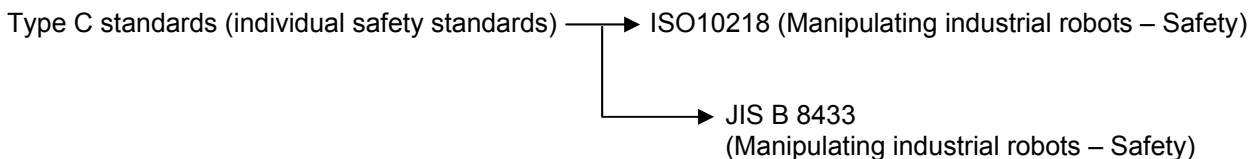

Also, Japanese laws regulate the safety of industrial robots, as follows:

Industrial Safety and Health Law Article 59

Workers engaged in dangerous or harmful operations must receive special education.

Ordinance on Industrial Safety and Health

Article 36 --- Operations requiring special education

- No. 31 (Teaching, etc.) --- Teaching and other similar work involving industrial robots (exceptions apply)
- No. 32 (Inspection, etc.) --- Inspection, repair, adjustment and similar work involving industrial robots (exceptions apply)

Article 150 --- Measures to be taken by the user of an industrial robot

Requirements for Industrial Robots under Ordinance on Industrial Safety and Health

Work area	Work condition	Cutoff of drive source	Measure	Article
Outside movement range	During automatic operation	Not cut off	Signs for starting operation	Article 104
			Installation of railings, enclosures, etc.	Article 150-4
Inside movement range	During teaching, etc.	Cut off (including stopping of operation)	Sign, etc., indicating that work is in progress	Article 150-3
		Not cut off	Preparation of work rules	Article 150-3
			Measures to enable immediate stopping of operation	Article 150-3
			Sign, etc., indicating that work is in progress	Article 150-3
			Provision of special education	Article 36-31
	Checkup, etc., before commencement of work		Article 151	
	During inspection, etc.	Cut off	To be performed after stopping the operation	Article 150-5
			Sign, etc., indicating that work is in progress	Article 150-5
		Not cut off (when inspection, etc., must be performed during operation)	Preparation of work rules	Article 150-5
			Measures to enable immediate stopping of operation	Article 150-5
Sign, etc., indicating that work is in progress			Article 150-5	
Provision of special education (excluding cleaning and lubrication)	Article 36-32			

Applicable Modes of IAI's Industrial Robot

Machines meeting the following conditions are not classified as industrial robots according to Notice of Ministry of Labor No. 51 and Notice of Ministry of Labor/Labor Standards Office Director (Ki-Hatsu No. 340):

- (1) Single-axis robot with a motor wattage of 80 W or less
- (2) Combined multi-axis robot whose X, Y and Z-axes are 300 mm or shorter and whose rotating part, if any, has the maximum movement range of within 300 mm³ including the tip of the rotating part
- (3) Multi-joint robot whose movable radius and Z-axis are within 300 mm

Among the products featured in our catalogs, the following models are classified as industrial robots:

1. Single-axis ROBO Cylinders
RCS2/RCS2CR-SS8□ and RCS3/RCS3CR/RCS3P/RCS3PCR whose stroke exceeds 300 mm
2. Single-axis robots
The following models whose stroke exceeds 300 mm and whose motor capacity also exceeds 80 W:
ISA/ISPA, ISDA/ISPDA, ISWA/ISPWA, IF, FS, NS
3. Linear servo actuators
All models whose stroke exceeds 300 mm
4. Cartesian robots
Any robot that uses at least one axis corresponding to one of the models specified in 1 to 3
5. IX SCARA robots
All models whose arm length exceeds 300 mm
(All models excluding IX-NNN1205/1505/1805/2515, NNW2515 and NNC1205/1505/1805/2515)

Notes on Safety of Our Products

Common items you should note when performing each task on any IAI robot are explained below.





No.	Task	Note
1	Model selection	<ul style="list-style-type: none"> ● This product is not planned or designed for uses requiring high degrees of safety. Accordingly, it cannot be used to sustain or support life and must not be used in the following applications: <ul style="list-style-type: none"> [1]Medical devices relating to maintenance, management, etc., of life or health [2]Mechanisms or mechanical devices (vehicles, railway facilities, aircraft facilities, etc.) intended to move or transport people [3]Important safety parts in mechanical devices (safety devices, etc.) ● Do not use this product in the following environments: <ul style="list-style-type: none"> [1]Place subject to flammable gases, ignitable objects, flammables, explosives, etc. [2]Place that may be exposed to radiation [3]Place where the surrounding air temperature or relative humidity exceeds the specified range [4]Place subject to direct sunlight or radiated heat from large heat sources [5]Place subject to sudden temperature shift and condensation [6]Place subject to corrosive gases (sulfuric acid, hydrochloric acid, etc.) [7]Place subject to excessive dust, salt or iron powder [8]Place where the product receives direct vibration or impact ● Do not use this product outside the specified ranges. Doing so may significantly shorten the life of the product or result in product failure or facility stoppage.
2	Transportation	<ul style="list-style-type: none"> ● When transporting the product, exercise due caution not to bump or drop the product. ● Use appropriate means for transportation. ● Do not step on the package. ● Do not place on the package any heavy article that may deform the package. ● When using a crane of 1 ton or more in capacity, make sure the crane operators are qualified to operate cranes and perform slinging work. ● When using a crane, etc., never hoist articles exceeding the rated load of the crane, etc. ● Use hoisting equipment suitable for the article to be hoisted. Calculate the load needed to cut off the hoisting equipment and other loads incidental to equipment operation by considering a safety factor. Also check the hoisting equipment for damage. ● Do not climb onto the article while it is being hoisted. ● Do not keep the article hoisted for an extended period of time. ● Do not stand under the hoisted article.
3	Storage/preservation	<ul style="list-style-type: none"> ● The storage/preservation environment should conform to the installation environment. Among others, be careful not to cause condensation.
4	Installation/startup	<p>(1) Installing the robot, controller, etc.</p> <ul style="list-style-type: none"> ● Be sure to firmly secure and affix the product (including its work part). If the product tips over, drops, malfunctions, etc., damage or injury may result. ● Do not step on the product or place any article on top. The product may tip over or the article may drop, resulting in injury, product damage, loss of/drop in product performance, shorter life, etc. ● If the product is used in any of the following places, provide sufficient shielding measures: <ul style="list-style-type: none"> [1]Place subject to electrical noise [2]Place subject to a strong electric or magnetic field [3]Place where power lines or drive lines are wired nearby [4]Place subject to splashed water, oil or chemicals

No.	Task	Note
4	Installation/ startup	<p>(2) Wiring the cables</p> <ul style="list-style-type: none"> ● Use IAI's genuine cables to connect the actuator and controller or connect a teaching tool, etc. ● Do not damage, forcibly bend, pull, loop round an object or pinch the cables or place heavy articles on top. Current leak or poor electrical continuity may occur, resulting in fire, electric shock or malfunction. ● Wire the product correctly after turning off the power. ● When wiring a DC power supply (+24 V), pay attention to the positive and negative polarities. Connecting the wires in wrong polarities may result in fire, product failure or malfunction. ● Securely connect the cables and connectors so that they will not be disconnected or come loose. Failing to do so may result in fire, electric shock or product malfunction. ● Do not cut and reconnect the cables of the product to extend or shorten the cables. Doing so may result in fire or product malfunction. <p>(3) Grounding</p> <ul style="list-style-type: none"> ● Be sure to provide class D (former class 3) grounding for the controller. Grounding is required to prevent electric shock and electrostatic charges, improve noise resistance and suppress unnecessary electromagnetic radiation. <p>(4) Safety measures</p> <ul style="list-style-type: none"> ● Implement safety measures (such as installing safety fences, etc.) to prevent entry into the movement range of the robot when the product is moving or can be moved. Contacting the moving robot may result in death or serious injury. ● Be sure to provide an emergency stop circuit so that the product can be stopped immediately in case of emergency during operation. ● Implement safety measures so that the product cannot be started only by turning on the power. If the product starts suddenly, injury or product damage may result. ● Implement safety measures so that the product will not start upon cancellation of an emergency stop or recovery of power following a power outage. Failure to do so may result in injury, equipment damage, etc. ● Put up a sign saying "WORK IN PROGRESS. DO NOT TURN ON POWER," etc., during installation, adjustment, etc. If the power is accidentally turned on, electric shock or injury may result. ● Implement measures to prevent the work part, etc., from dropping due to a power outage or emergency stop. ● Ensure safety by wearing protective gloves, protective goggles and/or safety shoes, as necessary. ● Do not insert fingers and objects into openings in the product. Doing so may result in injury, electric shock, product damage, fire, etc. ● When releasing the brake of the vertically installed actuator, be careful not to let the actuator drop due to its dead weight, causing pinched hands or damaged work part, etc.
5	Teaching	<ul style="list-style-type: none"> ● Whenever possible, perform teaching from outside the safety fences. If teaching must be performed inside the safety fences, prepare "work rules" and make sure the operator understands the procedures thoroughly. ● When working inside the safety fences, the operator should carry a handy emergency stop switch so that the operation can be stopped any time when an abnormality occurs. ● When working inside the safety fences, appoint a safety watcher in addition to the operator so that the operation can be stopped any time when an abnormality occurs. The safety watcher must also make sure the switches are not operated inadvertently by a third party. ● Put up a sign saying "WORK IN PROGRESS" in a conspicuous location.

No.	Task	Note
5	Teaching	<ul style="list-style-type: none"> ● When releasing the brake of the vertically installed actuator, be careful not to let the actuator drop due to its dead weight, causing pinched hands or damaged load, etc. * Safety fences --- Indicate the movement range if safety fences are not provided.
6	Confirmation operation	<ul style="list-style-type: none"> ● After teaching or programming, carry out step-by-step confirmation operation before switching to automatic operation. ● When carrying out confirmation operation inside the safety fences, follow the specified work procedure just like during teaching. ● When confirming the program operation, use the safety speed. Failure to do so may result in an unexpected movement due to programming errors, etc., causing injury. ● Do not touch the terminal blocks and various setting switches while the power is supplied. Touching these parts may result in electric shock or malfunction.
7	Automatic operation	<ul style="list-style-type: none"> ● Before commencing automatic operation, make sure no one is inside the safety fences. ● Before commencing automatic operation, make sure all related peripherals are ready to operate in the auto mode and no abnormalities are displayed or indicated. ● Be sure to start automatic operation from outside the safety fences. ● If the product generated abnormal heat, smoke, odor or noise, stop the product immediately and turn off the power switch. Failure to do so may result in fire or product damage. ● If a power outage occurred, turn off the power switch. Otherwise, the product may move suddenly when the power is restored, resulting in injury or product damage.
8	Maintenance/ inspection	<ul style="list-style-type: none"> ● Whenever possible, work from outside the safety fences. If work must be performed inside the safety fences, prepare “work rules” and make sure the operator understands the procedures thoroughly. ● When working inside the safety fences, turn off the power switch, as a rule. ● When working inside the safety fences, the operator should carry a handy emergency stop switch so that the operation can be stopped any time when an abnormality occurs. ● When working inside the safety fences, appoint a safety watcher in addition to the operator so that the operation can be stopped any time when an abnormality occurs. The safety watcher must also make sure the switches are not operated inadvertently by a third party. ● Put up a sign saying “WORK IN PROGRESS” in a conspicuous location. ● Use appropriate grease for the guides and ball screws by checking the operation manual for each model. ● Do not perform a withstand voltage test. Conducting this test may result in product damage. ● When releasing the brake of the vertically installed actuator, be careful not to let the actuator drop due to its dead weight, causing pinched hands or damaged work part, etc. * Safety fences --- Indicate the movement range if safety fences are not provided.
9	Modification	<ul style="list-style-type: none"> ● The customer must not modify or disassemble/assemble the product or use maintenance parts not specified in the manual without first consulting IAI. ● Any damage or loss resulting from the above actions will be excluded from the scope of warranty.
10	Disposal	<ul style="list-style-type: none"> ● When the product becomes no longer usable or necessary, dispose of it properly as an industrial waste. ● When disposing of the product, do not throw it into fire. The product may explode or generate toxic gases.

Indication of Cautionary Information

The operation manual for each model denotes safety precautions under “Danger,” “Warning,” “Caution” and “Note,” as specified below.

Level	Degree of danger/loss	Symbol
Danger	Failure to observe the instruction will result in an imminent danger leading to death or serious injury.	 Danger
Warning	Failure to observe the instruction may result in death or serious injury.	 Warning
Caution	Failure to observe the instruction may result in injury or property damage.	 Caution
Note	The user should take heed of this information to ensure the proper use of the product, although failure to do so will not result in injury.	 Note

RC ROBO CYLINDER

1. Overview

1.1 Introduction

Thank you for purchasing the Easy All-in-One Robo Cylinder (hereinafter referred to as “ERC”). This manual explains the features and operating procedures of the product.

If not used or handled properly, even a brilliant product cannot fully demonstrate its function or may cause an unexpected breakdown or end its life prematurely. Please read this manual carefully and handle the product with utmost care while ensuring its correct operation. Keep this manual in a convenient place so the relevant sections can be referenced readily when necessary.

If you are also using the optional PC software or teaching pendant, also refer to the operation manual for the applicable item.

* We have made every effort to ensure accuracy of the information provided in this manual. Should you find an error, however, or if you have any comment, please contact IAI.
Keep this manual in a convenient place so it can be referenced readily when necessary.

1.2 Meaning of the Model Name

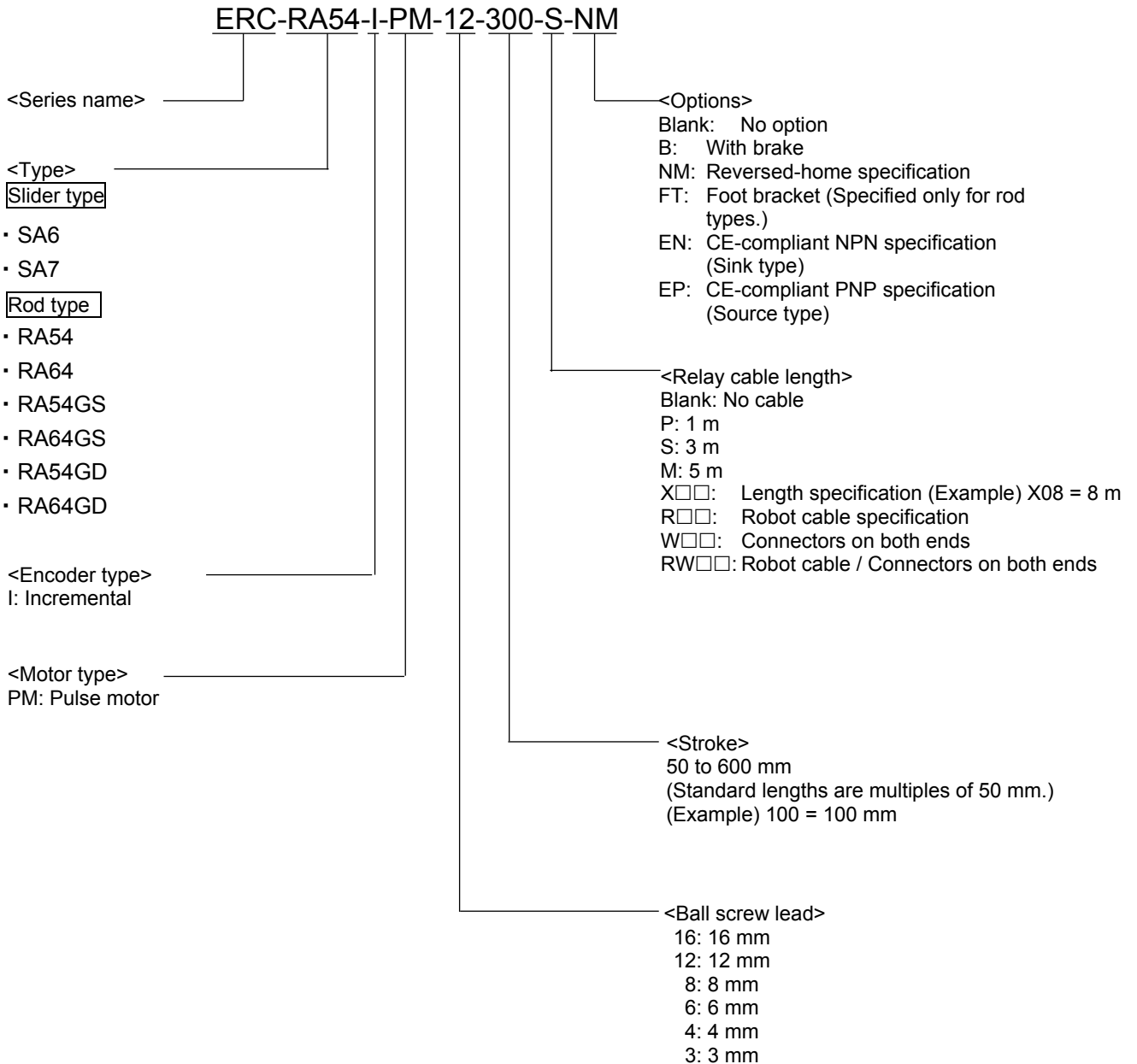

1.3 Specifications

	Model	Stroke (mm) and maximum speed (mm/sec) (Note 1)												Load capacity (Note 2)		Rated acceleration	
														Horizontal	Vertical	Horizontal	Vertical
		50	100	150	200	250	300	350	400	450	500	550	600	(kg)	(kg)	(G)	(G)
Slider type	ERC-SA6-I-PM-12-□□□	600											515	6~2	1.5~1	0.3	0.2
	ERC-SA6-I-PM-6-□□□	300											255	12	3~2.5	0.3	0.2
	ERC-SA6-I-PM-3-□□□	150											125	12	6~4	0.2	0.2
	ERC-SA7-I-PM-16-□□□	450 (400)												10~2	2.5~0.5	0.3	0.2
	ERC-SA7-I-PM-8-□□□	250												20~3.5	5~0.5	0.3	0.2
	ERC-SA7-I-PM-4-□□□	125												20	10~2	0.2	0.2
Rod type	ERC-RA54-I-PM-12-□□□	600											500	25~2.5	4.5~0.5	0.3	0.2
	ERC-RA54-I-PM-6-□□□	300											250	40~12	12~2.5	0.3	0.2
	ERC-RA54-I-PM-3-□□□	150											125	40	18~4	0.2	0.2
	ERC-RA64-I-PM-16-□□□	450 (400)												40~2	5~0.5	0.3	0.2
	ERC-RA64-I-PM-8-□□□	250 (200)												50~3.5	17.5~1	0.3	0.2
	ERC-RA64-I-PM-4-□□□	125												55~2.5	2.5~2	0.2	0.2
	ERC-RA54GS-I-PM-12-□□□	600											500	25~2.5	4.5~0.5	0.3	0.2
	ERC-RA54GS-I-PM-6-□□□	300											250	40~12	12~2.5	0.3	0.2
	ERC-RA54GS-I-PM-3-□□□	150											125	40	18~4	0.2	0.2
	ERC-RA64GS-I-PM-16-□□□	500												40~2	5~0.5	0.3	0.2
	ERC-RA64GS-I-PM-8-□□□	250												50~3.5	17.5~1	0.3	0.2
	ERC-RA64GS-I-PM-4-□□□	125												55~2.5	2.5~2	0.2	0.2
	ERC-RA54GD-I-PM-12-□□□	600											500	25~2.5	4.5~0.5	0.3	0.2
	ERC-RA54GD-I-PM-6-□□□	300											250	40~12	12~2.5	0.3	0.2
	ERC-RA54GD-I-PM-3-□□□	150											125	40	18~4	0.2	0.2
	ERC-RA64GD-I-PM-16-□□□	500												40~2	5~0.5	0.3	0.2
	ERC-RA64GD-I-PM-8-□□□	250												50~3.5	17.5~1	0.3	0.2
	ERC-RA64GD-I-PM-4-□□□	125												55~2.5	2.5~2	0.2	0.2

(Note 1) The figures in blank bands indicate the maximum speeds for respective strokes. The maximum speeds during vertical operation are shown in parentheses.

(Note 2) The load capacity is based on operation at the rated acceleration. In the case of a guide type, find the applicable load capacity in the above table and subtract the weight of the guide to obtain the effective load capacity.

1.3.1 Correlation Diagrams of Speed and Load Capacity – Slider Type

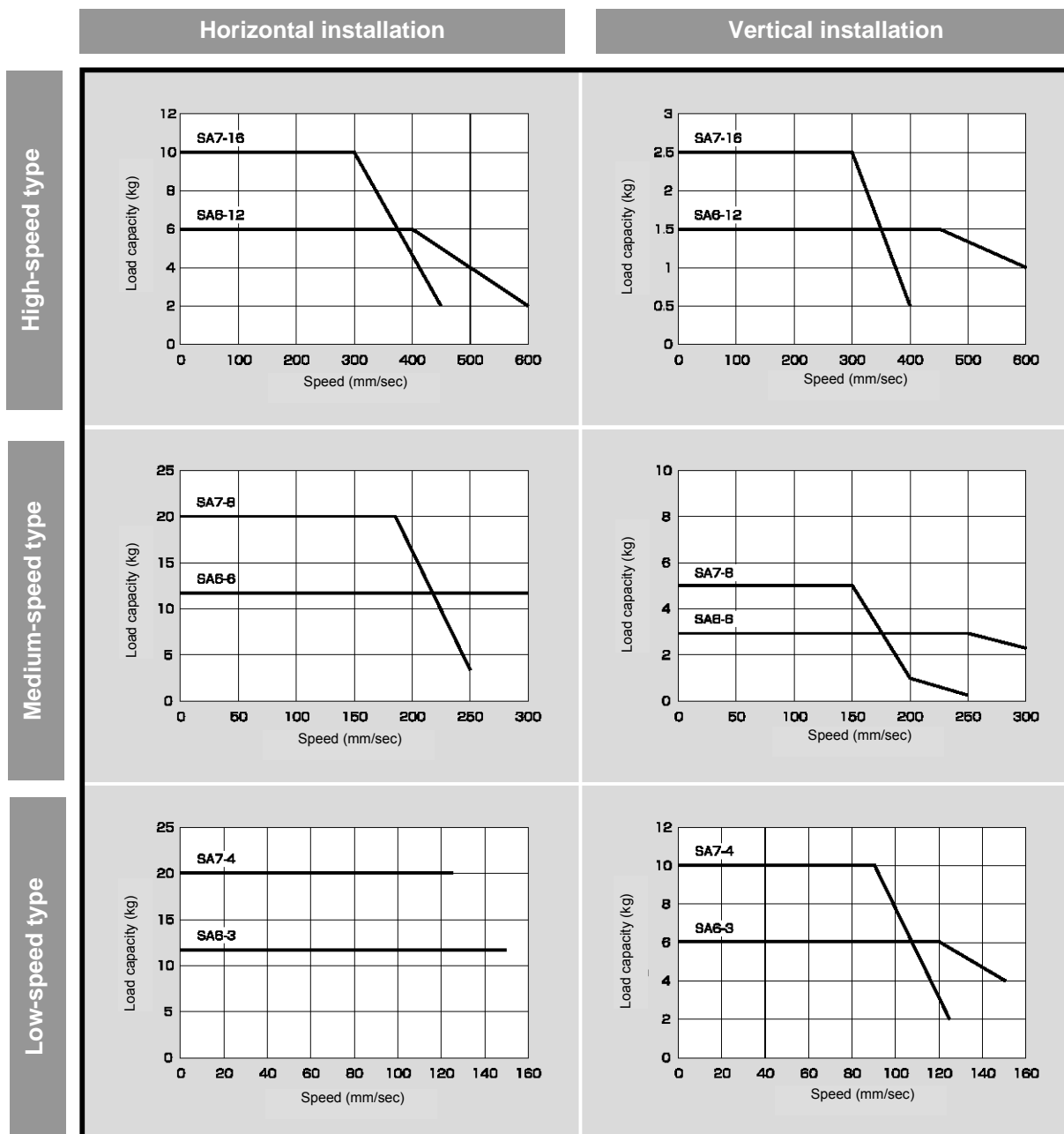

(Note) In the above graphs, the number after each type name indicates the lead.

1.3.2 Correlation Diagrams of Speed and Load Capacity – Rod Type

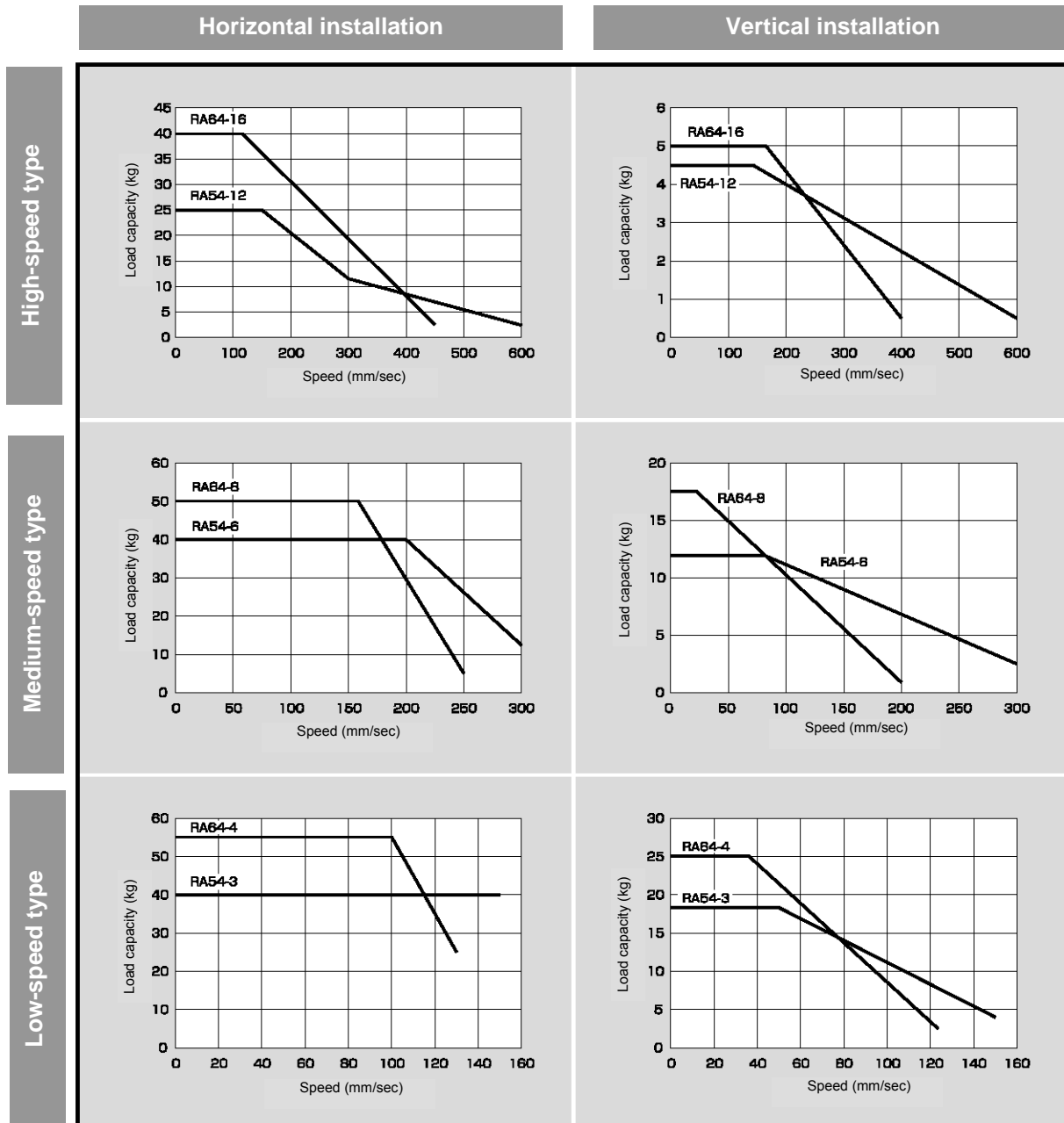

(Note) In the above graphs, the number after each type name indicates the lead.

⚠ Load Applied to the Actuator

(1) Slider type

- Keep the load applied to the slider below the value stated in the applicable specification item. In particular, pay attention to the moment applied to the slider, allowable overhung length and load capacity.
- If the slider is used in an overhung application with the load extending in the Y-axis direction, keep moments M_a and M_c to one-half the rated moment or less to prevent the base from deforming.

(2) Rod type

- Keep the load applied to the rod below the value specified in the catalog.
- Make sure the center of the rod axis corresponds to the moving direction of the load.

- Application of lateral load may cause an actuator damage or breakdown.
- If the rod is to be subjected to lateral load, provide a guide or other support in the moving direction of the load.

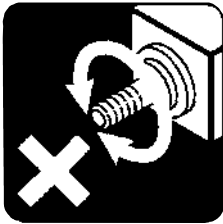

- Do not apply rotating torque to the rod (slide shaft).
* It will result in internal damages.

When tightening the nut at the tip of the rod, secure the rod using a wrench of size 13 (RA54 type) or 17 (RA64 type).

1.3.3 Sound Pressure Levels of This Product Will Not Exceed 70 dB.

1.4 Safety Precautions

Read the following information carefully and provide safety measures with due consideration.

This product has been developed as a drive component for automated machinery and the like, and is therefore designed not to generate excessive torque or speed beyond the levels needed to drive automated equipment. However, the following instructions must be strictly observed to prevent an unexpected accident.

1. Assume that the product cannot be handled or operated in any manner not specified in this manual, and do not attempt any such handling or operation.
2. Do not enter the operating range of the machine while the machine is operating or is able to operate (the controller power is ON). If the machine is used in a place accessible to other people, enclose its operating range using a safety cage, etc.
3. Always turn off the power supply to the controller before assembling/adjusting or maintaining/inspecting the machine. During assembly/adjustment or maintenance/inspection, put a plate or other visible sign in a conspicuous place indicating that work is in progress. Provide sufficient safety measures to prevent another person from inadvertently plugging in the cable during work.
4. If two or more persons work together, set signaling methods so each person can confirm the safety of other(s) during work. Especially when the work requires an axis or axes to be moved—with or without the power and by motor drive or manual operation—the person moving each axis should always call out beforehand to ensure safety.

1.5 Warranty Period and Scope of Warranty

The ERC you have purchased passed IAI's shipping inspection implemented under the strictest standards. The unit is covered by the following warranty:

1. Warranty Period

The warranty period shall be one of the following periods, whichever ends first:

- 18 months after shipment from our factory
- 12 months after delivery to a specified location

2. Scope of Warranty

If an obvious manufacturing defect is found during the above period under an appropriate condition of use, IAI will repair the defect free of charge. Note, however, that the following items are excluded from the scope of warranty:

- Aging such as natural discoloration of coating
- Wear of a consumable part due to use
- Noise or other sensory deviation that doesn't affect the mechanical function
- Defect caused by inappropriate handling or use by the user
- Defect caused by inappropriate or erroneous maintenance/inspection
- Defect caused by use of a part other than IAI's genuine part
- Defect caused by an alteration or other change not approved by IAI or its agent
- Defect caused by an act of God, accident, fire, etc.

The warranty covers only the product as it has been delivered and shall not cover any losses arising in connection with the delivered product. The defective product must be brought to our factory for repair.

Please read the above conditions of warranty carefully.

1.6 Transportation and Handling

1.6.1 Handling before Unpacking

Exercise due caution when transporting or handling the box containing the actuator, by not applying impact on the box as a result of collision or dropping.

- If the box is heavy, one person should not carry it by himself.
- Place the box in a level surface.
- Do not step on the box.
- Do not place on the box any heavy object that may cause the box to deform or other object with a section where loads will concentrate.

1.6.2 Handling after Unpacking

Once removed out of the box, hold the actuator by the frame if it is a rod type, or by the base if it is a slider type.

- When carrying the actuator, be careful not to allow it to collide with other objects. In particular, pay attention to the front bracket, motor bracket and motor cover.
- Do not exert excessive force on each part of the actuator. In particular, pay attention to the motor cover and cables.
- When unpacking, exercise due caution not to let the actuator drop and sustain damage to its mechanism.
- If the actuator is damaged during the shipment or any of the items is found missing, please contact IAI's Technical Support immediately.

Supplement) Refer to 2.1, "Name of Each Part," for the name of each part of the actuator.

1.7 Installation Environment and Noise Elimination

Pay due attention to the installation environment of the controller.

1.7.1 Installation Environment

The installation environment must satisfy the following conditions:

No.	Use environment/condition
[1]	Not exposed to direct sunlight.
[2]	The actuator is not subject to irradiated heat from a large heat source, such as a heat treatment furnace.
[3]	Ambient temperature of 0 to 40°C.
[4]	Humidity of 85% or less without condensation.
[5]	Not exposed to corrosive or flammable gases.
[6]	Normal environment for assembly and operation not subject to significant dust.
[7]	Not exposed to oil mist or cutting fluid.
[8]	Not subject to vibration exceeding 0.3 G.
[9]	Not exposed to strong electromagnetic waves, ultraviolet light or radiation.
[10]	Chemical resistance is not considered at all in the design of this product.
[11]	The actuator and cables are not subject to electrical noise.

In general, the installation environment shall be such that the operator can work without wearing any protective gears.

1.7.2 Storage Environment

The storage environment shall conform to the installation environment, but special caution is required to prevent condensation if the actuator is to be stored for a long period of time.

Unless otherwise specified, the actuator is shipped without any desiccating agent placed in the box. If the actuator is to be stored in an environment subject to condensation, provide a non-condensing measure from outside the box or directly inside the box.

The actuator is designed to withstand storage temperatures of up to 60°C for a short period of time. If the storage period will extend beyond one month, however, keep the ambient temperature below 50°C.

1.7.3 Power Supply

The control/motor-drive power supply specification is 24 VDC \pm 10% (2 A max).

1.7.4 Noise Elimination

This section explains how to eliminate noise in the use of the controller.

(1) Wiring and power supply

[1] Provide a dedicated class D grounding using a wire with a size of 0.75 mm² or larger.

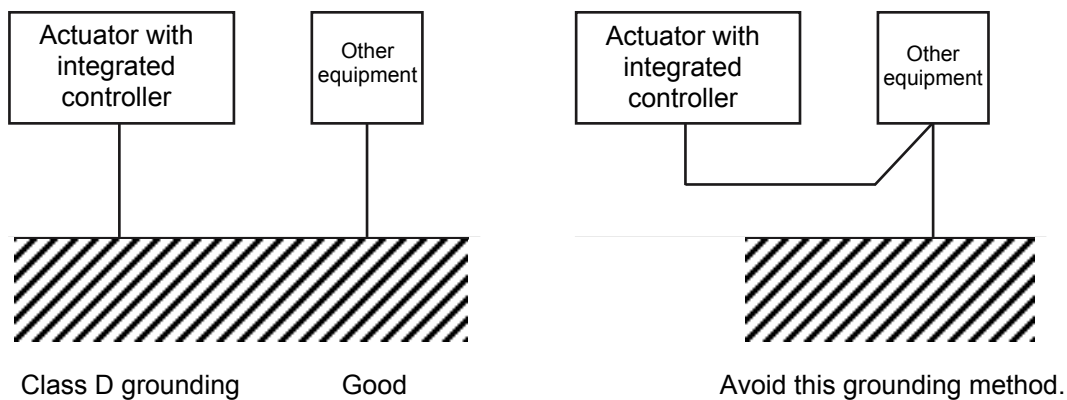

[2] Precautions regarding wiring method

Separate the controller cables from high-power lines such as a cable connecting to a power circuit. (Do not bundle together the controller cables with high-power lines or place them in the same cable duct.)

(2) Noise sources and elimination

Among the numerous noise sources, solenoid valves, magnet switches and relays are of particular concern when building a system. Noise from these sources can be eliminated by implementing the measures specified below.

[1] AC solenoid valves, magnet switches and relays

Measure: Install a surge absorber in parallel with the coil.

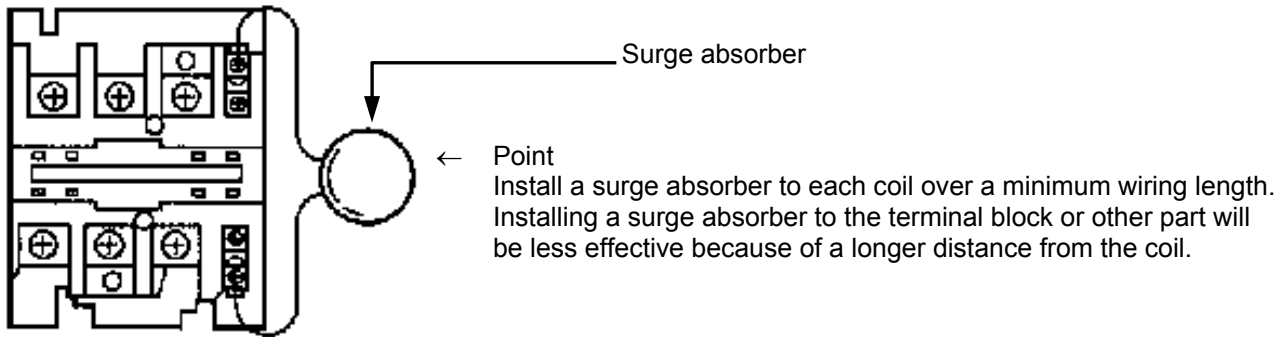

[2] DC solenoid valves, magnet switches and relays

Measure: Install a diode in parallel with the coil. Determine the diode capacity in accordance with the load capacity.

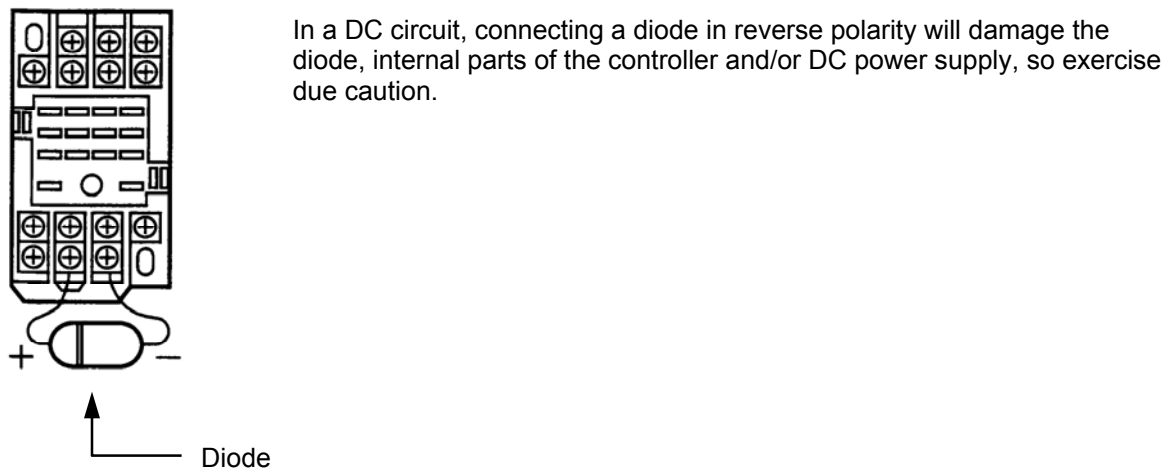

1.8 Cabling

- The standard relay cables have excellent flexibility to withstand fatigue from flexural loads, but they are not robot cables. Therefore, avoid storing the standard relay cables in movable cable ducts laid at a small radius. If they must be stored in movable cable ducts, use robot cables.
- In an application where the cable cannot be fixed, keep the cable from receiving a deflecting load exceeding its own weight, use a self-standing cable hose, provide a large bending radius along the wiring path, or provide other measure to minimize the load applied to the cable.
- Do not cut the cable for the purpose of extension, length reduction or reconnection.

If you intend to change the cable layout, please consult IAI.

Prohibited Handling of Cables

When designing an application system using this actuator, incorrect wiring or connection of each cable may cause unexpected problems such as a disconnected cable or poor contact, or even a runaway system. This section explains prohibited handling of cables. Read the information carefully to connect the cables properly.

1. Do not let the cable flex at a single point.

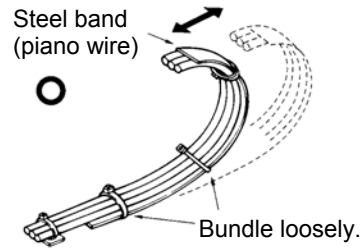
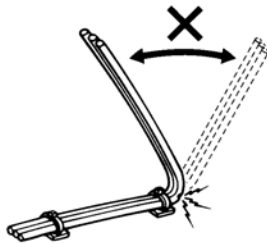

2. Do not let the cable bend, kink or twist.

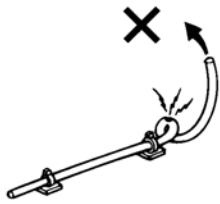

3. Do not pull the cable with a strong force.

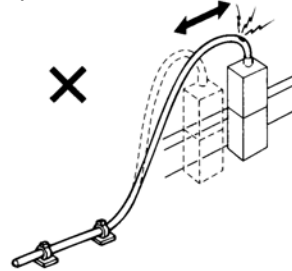

4. Do not let the cable receive a turning force at a single point.

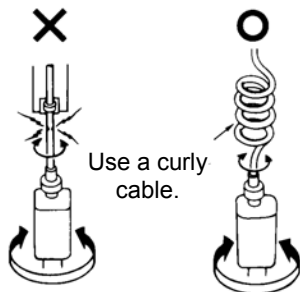

5. When fixing the cable, provide a moderate slack and do not tension it too tight.

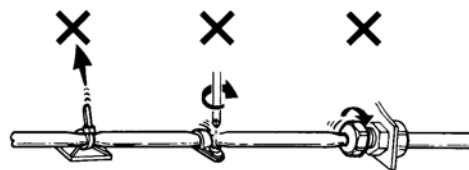

6. Do not pinch, drop a heavy object onto or cut the cable.

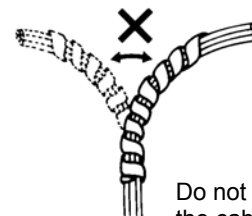
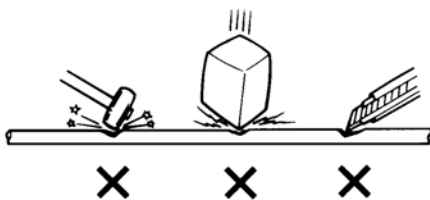

Do not use a spiral tube where the cable flexes frequently.

7. Notes on use of cable tracks

- The supplied cable is not a robot cable. Accordingly, never store this cable in a cable track.

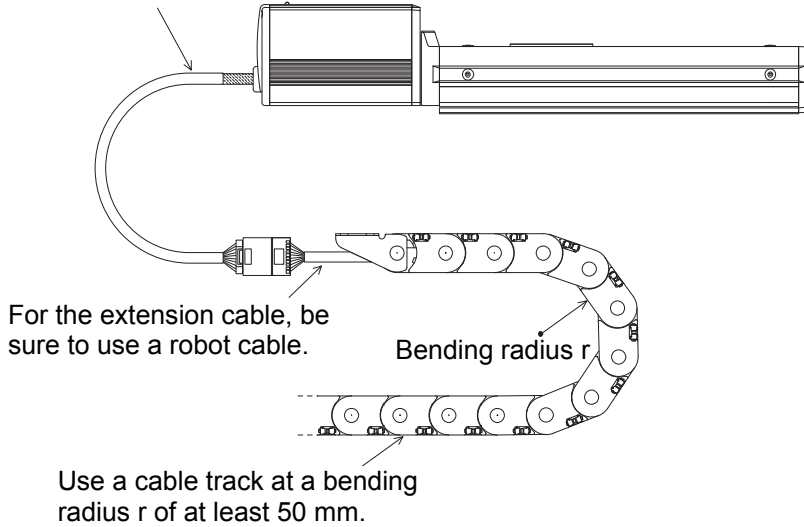

- PIO line, communication line, power and driving lines are to be put separately from each other and do not tie them together. Arrange so that such lines are independently routed in the duct.

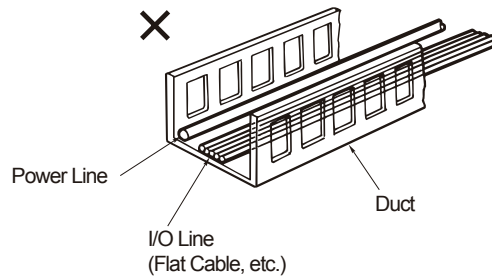

Follow the instructions below when using a cable track.

- If there is an indication to the cable for the space factor in a cable track, refer to the wiring instruction given by the supplier when storing the cable in the cable track.
- Avoid the cables to get twined or twisted in the cable track, and also to have the cables move freely and do not tie them up. (Avoid tension being applied when the cables are bent.) Do not pile up cables. It may cause faster abrasion of the sheaths or cable breakage.

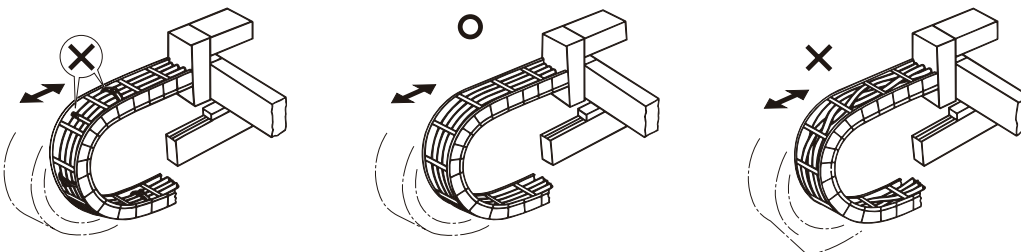

2. Installation

2.1 Name of Each Part

2.1.1 Slider Type (SA6/SA7)

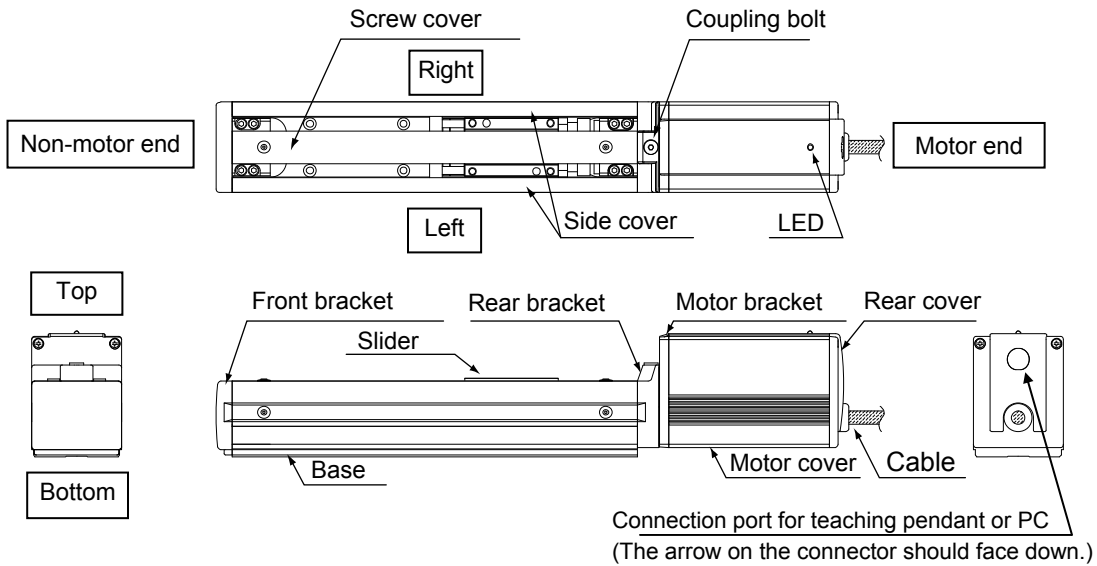

2.1.2 Rod Type (RA54/RA64)

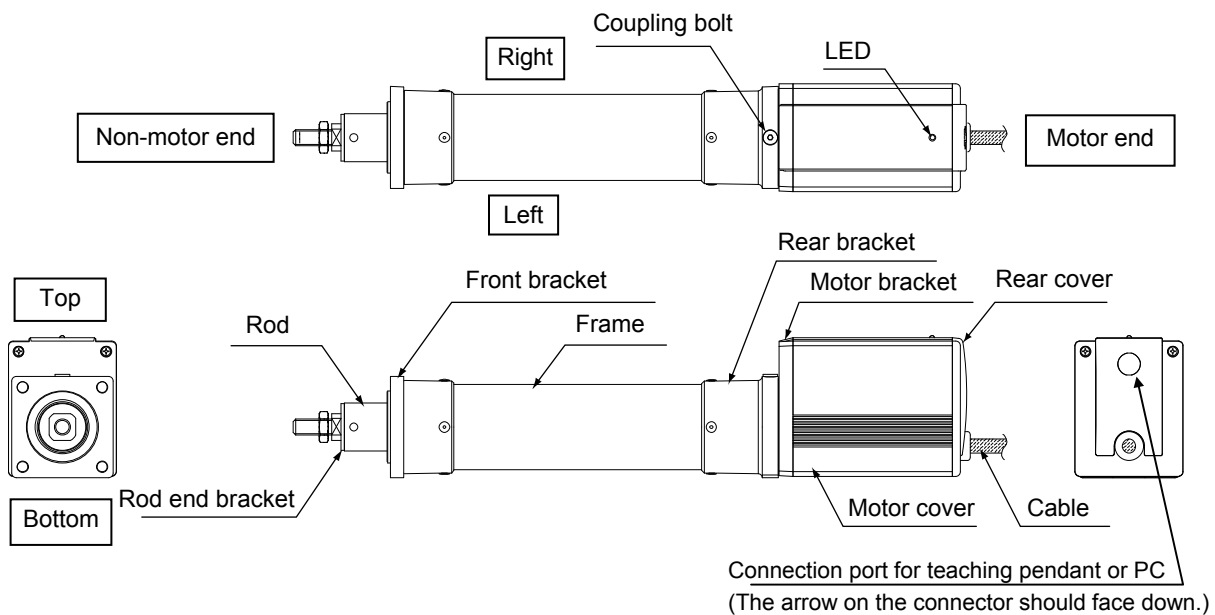

2.1.3 (1) Rod Type with a Single Guide (RA54GS/RA64GS)

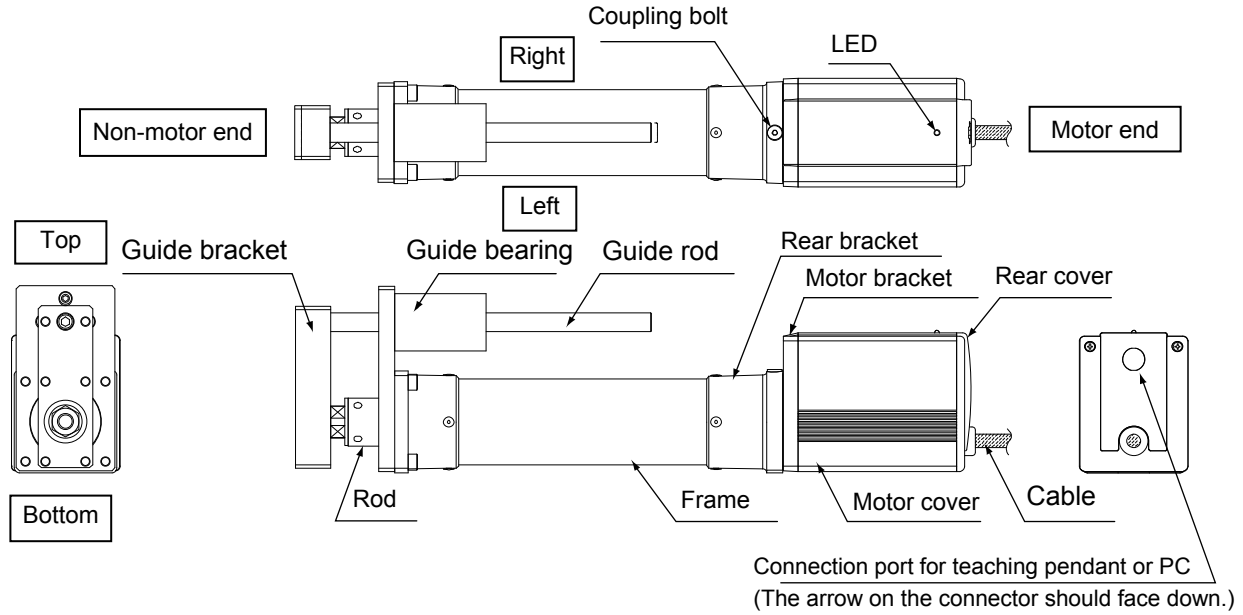

2.1.3 (2) Rod Type with Double Guides (RA54GD/RA64GD)

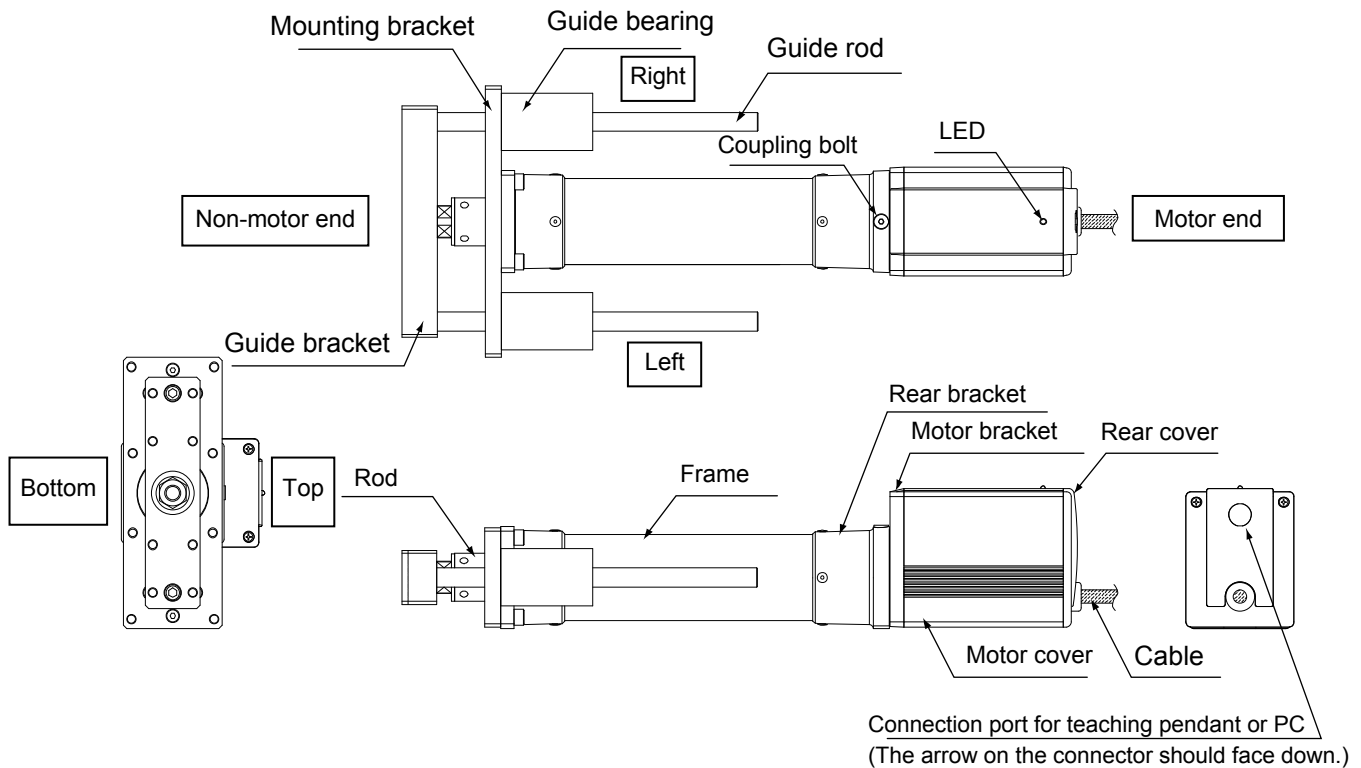

2.2 Installation

2.2.1 Slider Type

- Installing the actuator

The actuator-mounting surface must be a machined surface or have an equivalent flatness.

The side and bottom faces of the actuator base are parallel with the guides. If high slide accuracy is required, install the actuator by using these surfaces as references.

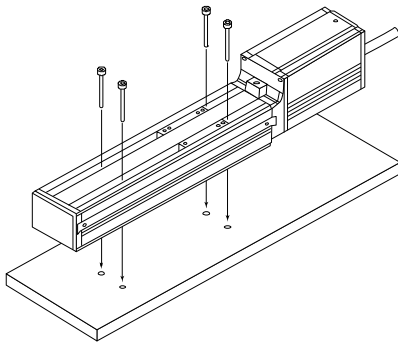

Install the actuator in the mounting holes provided in the base. Secure the actuator in place using M4 hex cap bolts.

Slider type

(Note) Reduced flatness due to installation of an overhung load will cause the base to deform and inhibit smooth movement of the slider. If the slider movement becomes heavier on the motor end or the slider begins generating noise, correct the flatness. Otherwise, the slider mechanism may end its life prematurely.

2.2.2 Rod Type

A rod-type actuator can be installed in the following two ways:

- Affixing with a flange

Install the actuator by tightening from the motor end side with hex cap bolts using the holes provided in the flange.

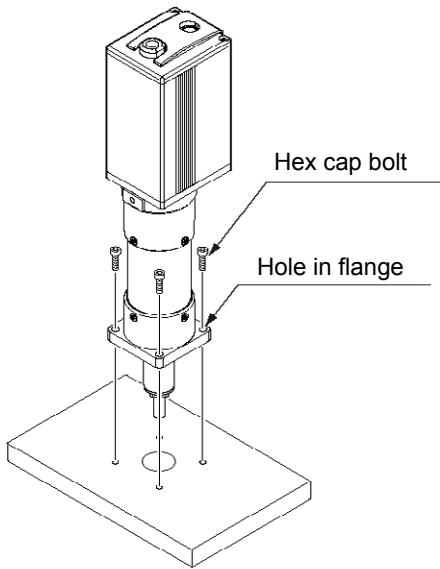

⚠ Caution: If the actuator is installed horizontally, exercise caution not to let the actuator receive excessive forces.

Flange tightening bolts

Model	Nominal thread size	Tightening torque
RA54	M5	3.4 N·m (0.35 kgf·m)
RA64	M6	5.4 N·m (0.55 kgf·m)

- Affixing through holes in a flange

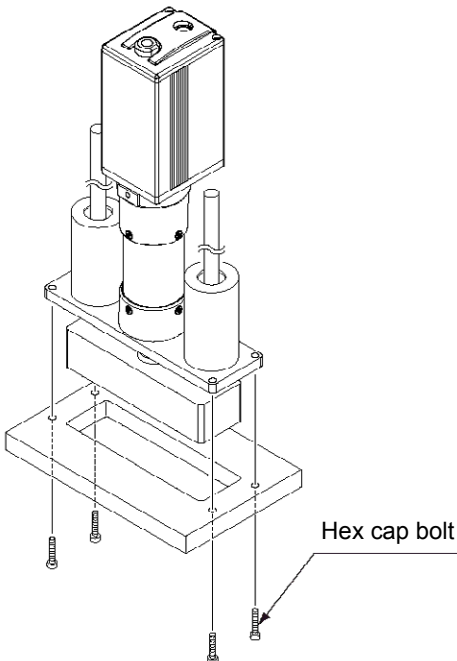

⚠ Caution: If the actuator is installed horizontally, exercise caution not to let the actuator receive excessive forces.

Flange tightening bolts

Model	Nominal thread size	Tightening torque
RA54GD	M5	Steel bolt-bearing surface: 7.3 N·m Aluminum bolt-bearing surface: 3.4 N·m
RA64GD	M6	Steel bolt-bearing surface: 12.3 N·m Aluminum bolt-bearing surface: 5.4 N·m

- Affixing with foot brackets (optional)

If optional foot brackets are used, install the foot brackets using hex cap bolts.

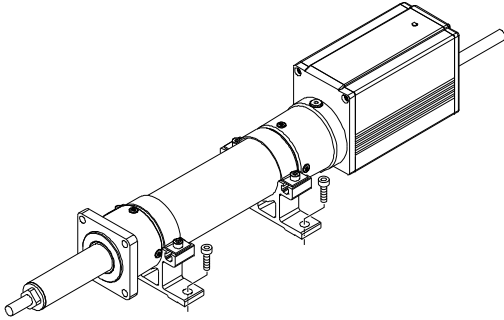

Foot-bracket tightening bolts

Model	Nominal thread size	Tightening torque
RA54 RA54GS RA54GD	M6	5.4 N·m (0.55 kgf·m)
RA64 RA64GS RA64GD	M8	11.5 N·m (1.17 kgf·m)

2.2.3 Installing the Load

- Slider Type

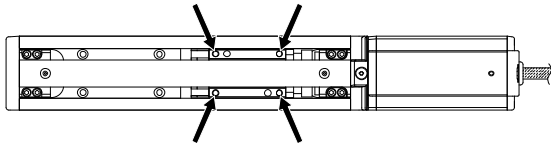

Four tapped holes are provided in the slider, so affix the load using these holes (indicated by arrows in the figure shown to the left).

Type	Slider mounting hole
SA6, SA7	M5, depth 9 mm

Nominal thread size	Tightening torque	
	Bolt bearing surface: steel	Bolt bearing surface: aluminum
M5	7.3 N·m (0.74 kgf·m)	3.4 N·m (0.35 kgf·m)

The affixing method of the load shall conform to the installation method of the actuator.

In an application where the actuator is moved with the slider fixed, install the load using the tapped holes in the slider in the same manner.

The slider has two reamed holes. Use these holes when high repeatability is required for load installation/removal. When fine-tuning the squareness of the load, etc., make adjustment by using one of these two reamed holes in the slider.

Type	Reamed hole
SA6, SA7	∅5, H10, depth 10 mm

● Rod Type

A bolt is attached on the rod end bracket, so use this bolt to affix the load. (Use the supplied nut, if necessary.)

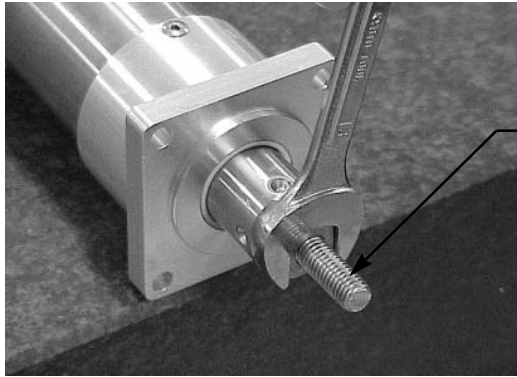

Rod end bracket

Model	Rod end bracket
RA54	M8, length 18 mm
RA64	M10, length 21 mm

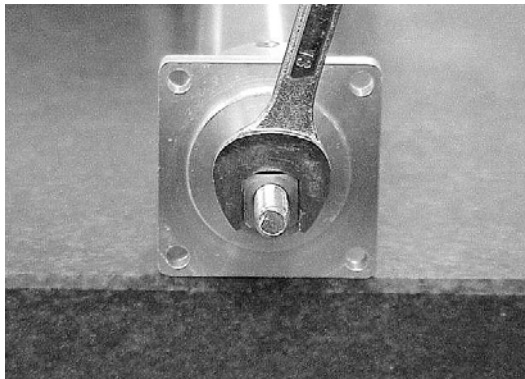

Note) Apply a spanner at the rod end bracket to prevent the rod from receiving any rotating moment when the load is installed.
 Applying excessive rotating moment to the rod may damage the rod.
 RA54: Width across flats 13 mm
 RA64: Width across flats 17 mm

● Rod type with a guide(s)

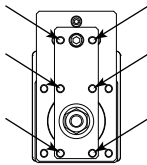

Single guide

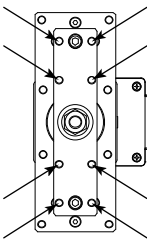

Double guides

Tapped holes are provided in the guide bracket. Affix the work using these holes (shown by the arrows in the figures at left).

Model	Nominal thread size
RA54GS	M5
RA54GD	M5
RA64GS	M6
RA64GD	M6

Nominal thread size	Tightening torque	
	Bolt bearing surface: steel	Bolt bearing surface: aluminum
M5	7.3 N·m (0.74 kgf·m)	3.4 N·m (0.35 kgf·m)
M6	12.3 N·m (1.26 kgf·m)	5.4 N·m (0.55 kgf·m)

3. Wiring

3.1 Basic Structure

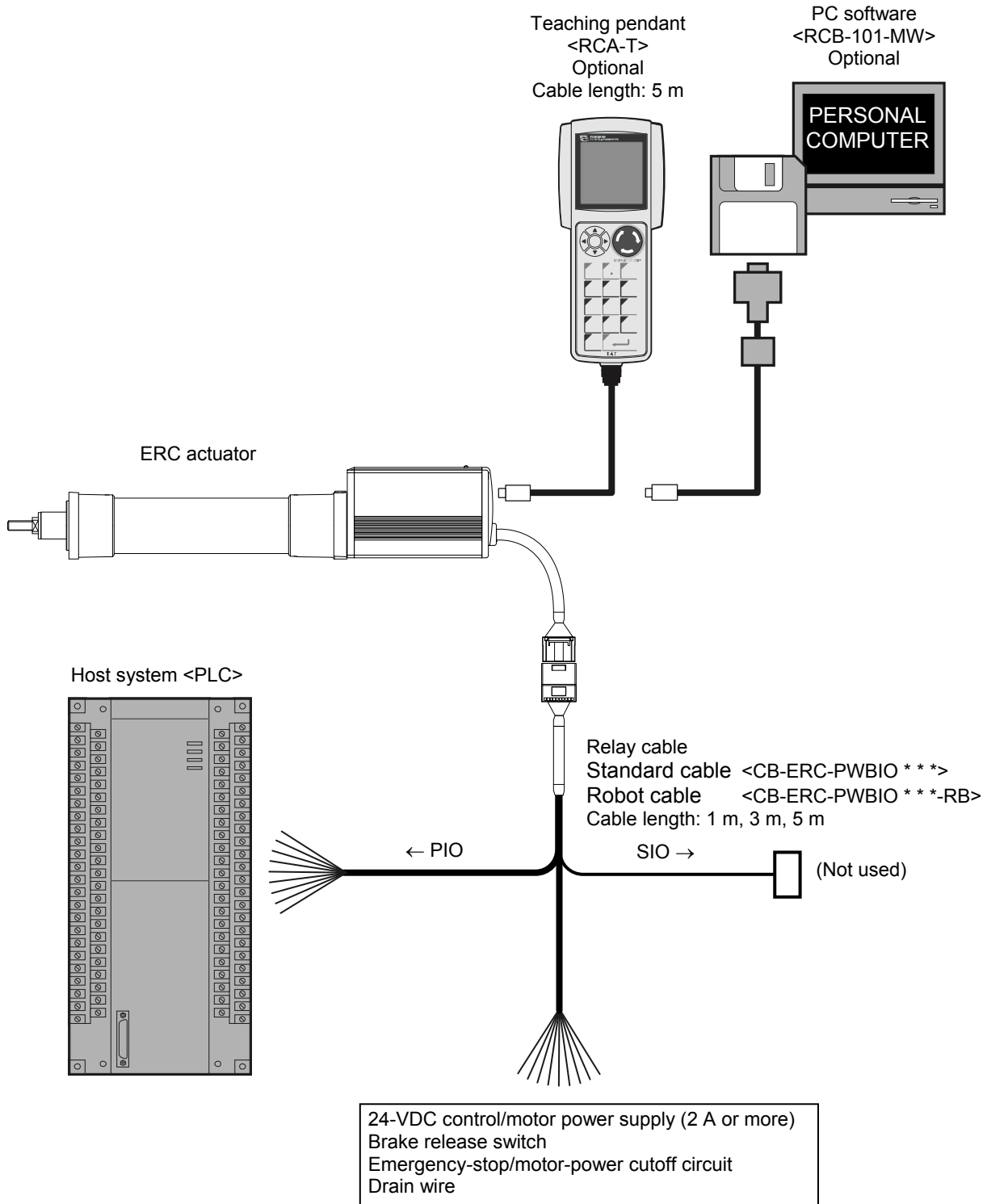

● Connection diagram

[1] When the control board is of the NPN specification [sink type]

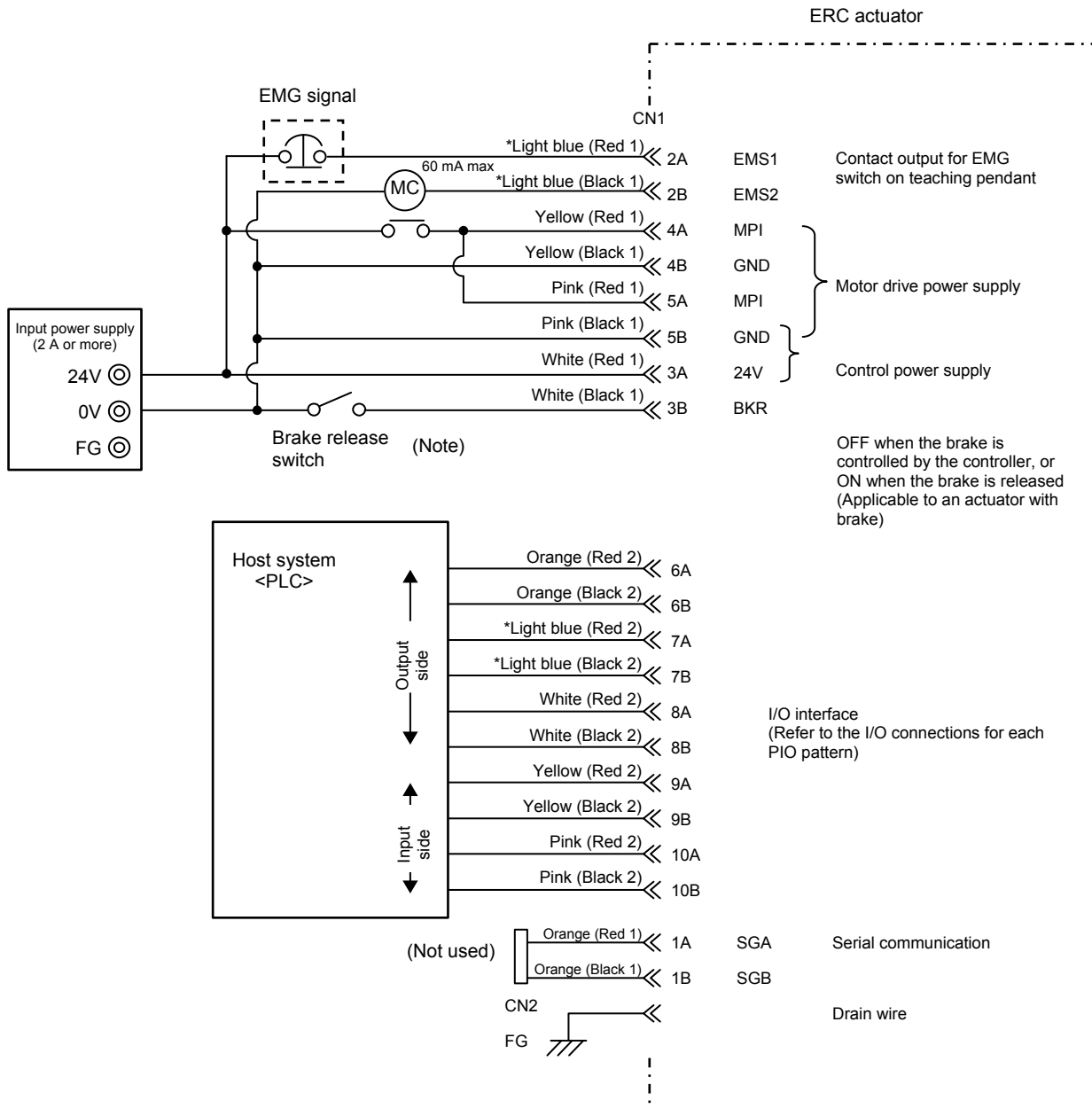

* In the case of a robot cable, the wire colors change as follows.

Wire color	Pin number
Gray (Red 1)	2A
Gray (Black 1)	2B
Gray (Red 2)	7A
Gray (Black 2)	7B

(Note) To release the brake, connect a switch between BKR and 0 V and turn on the switch.

3.2 I/O Connections for PIO Pattern 1 [3 Points] (Air Cylinder)

The following description assumes that the ERC is used in the place of an air cylinder. The number of positioning points is limited to three, but a direct command input and a position complete output are provided separately for the target position in line with the conventional practice of air cylinder control.

Note: The factory setting is “8 points,” so set parameter No. 25 to “1.” The pause signal can be disabled in parameter No. 15.

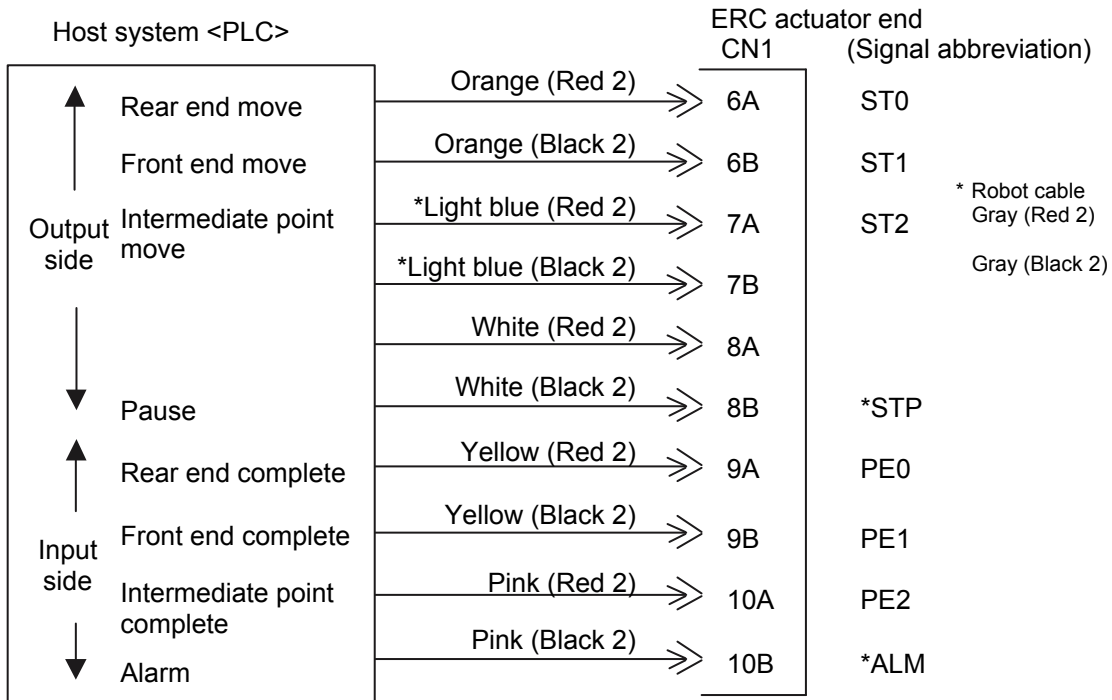

(Note) *STP and *ALM are always ON.

3.2.1 Explanation of I/O Signals

Category	Signal name	Signal abbreviation	Function overview
Input	Rear end move	ST0	The actuator starts moving to the rear end at the rise edge of the signal.
	Front end move	ST1	The actuator starts moving to the front end at the rise edge of the signal.
	Intermediate point move	ST2	The actuator starts moving to the intermediate point at the rise edge of the signal.
	*Pause	*STP	ON: The actuator can be moved, OFF: The actuator decelerates to a stop
Output	Rear end complete	PE0	The signal turns ON when the actuator completes moving to the rear end.
	Front end complete	PE1	The signal turns ON when the actuator completes moving to the front end.
	Intermediate point complete	PE2	The signal turns ON when the actuator completes moving to the intermediate point.
	*Alarm	*ALM	This signal remains ON while the controller is operating properly, and turns OFF when an alarm generates. The *ALM signal is synchronized with the green/red indication of the LED. (Note) The signal remains ON while the motor drive power is cut off.

3.2.2 Details of Input Signals

The input signals from this controller have an input time constant, in order to prevent malfunction caused by chattering, noise, etc.

Each input signal will switch the applicable setting when received continuously for 6 msec or more.

In other words, when a given input is switched from OFF to ON, the controller will recognize the ON state of the signal only after elapse of 6 msec.

The same applies to the switching of an input from ON to OFF. (Fig. 1)

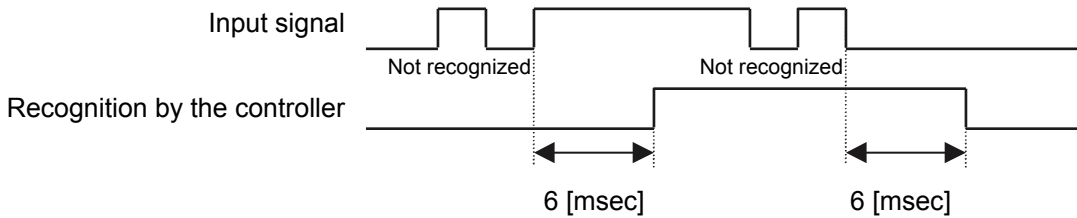

Fig. 1 Recognition of Input Signal

■ Movement to each position (ST0 to ST2)

When the OFF → ON rise edge of each movement signal is detected, the actuator will move to the target position corresponding to the applicable position data.

Before executing a command using any of these signals, make sure the target position, speed and other operation data are set in the position table using a PC or teaching pendant.

Input signal	Corresponding position number	Remarks
Rear end move (ST0)	0	Set the rear end position in position No. 0.
Front end move (ST1)	1	Set the front end position in position No. 1.
Intermediate point 1 move (ST2)	2	Set the intermediate point in position No. 2.

If a movement command is issued when the first home return is not yet completed after the power was input, home return will be performed automatically to establish the coordinates first, after which the actuator will move to the target position.

■ Pause (*STP)

When this signal turns OFF while the actuator is moving, the actuator will decelerate to a stop.

The remaining movement is retained and will be resumed when the signal is turned ON again.

The *STP signal can be used for the following purposes:

- [1] Provide a low-level safety measure to stop the axis while the servo is ON, such as a sensor that detects a person approaching the system
- [2] Prevent contact with other equipment
- [3] Perform positioning based on sensor or LS detection

(Note) If the *STP signal is input while the actuator is performing home return, the movement command will be retained if the actuator is yet to contact a mechanical end. If the signal is input after the actuator has reversed upon contacting a mechanical end, home return will be performed again from the beginning.

3.2.3 Details of Output Signals

■ Completion of each position (PE0 to PE2)

These signals indicate that the target position corresponding to each movement command (ST0, ST1 or ST2) has been reached, in the same way the reed switch signal does for an air cylinder.

Output signal	Meaning of the signal
Rear end complete (PE0)	The actuator has reached and stopped at the rear end (target position set in position No. 0).
Front end complete (PE1)	The actuator has reached and stopped at the front end (target position set in position No. 1).
Intermediate point complete (PE2)	The actuator has reached and stopped at the intermediate point (target position set in position No. 2).

(Note) Although these signals remain OFF while the motor drive power is cut off, once the power is reconnected the signal will return to the ON state if the current actuator position is within the in-position band over the target position. If the actuator is positioned outside the in-position band, the signal will remain OFF.

■ Alarm (*ALM)

This signal remains ON while the controller is operating properly, and turns OFF when an alarm generates. Monitor the OFF state on PLC and provide appropriate safety measures for the entire system. Refer to “9. Troubleshooting” for alarm details.

3.3 I/O Connections for PIO Pattern 0 [8 Points]

Note The factory setting is "8 points." The pause signal can be disabled in parameter No. 15.

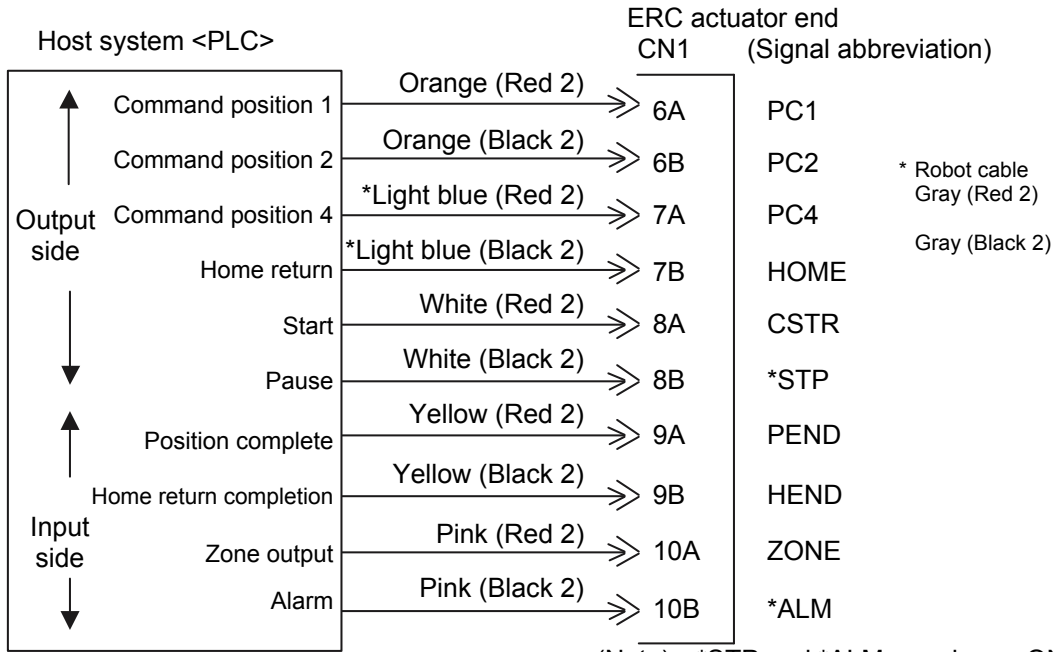

(Note) *STP and *ALM are always ON.

3.4 I/O Connections for PIO Pattern 2 [16 Points]

Note The factory setting is "8 points," so set parameter No. 25 to "2." The pause signal can be disabled in parameter No. 15.

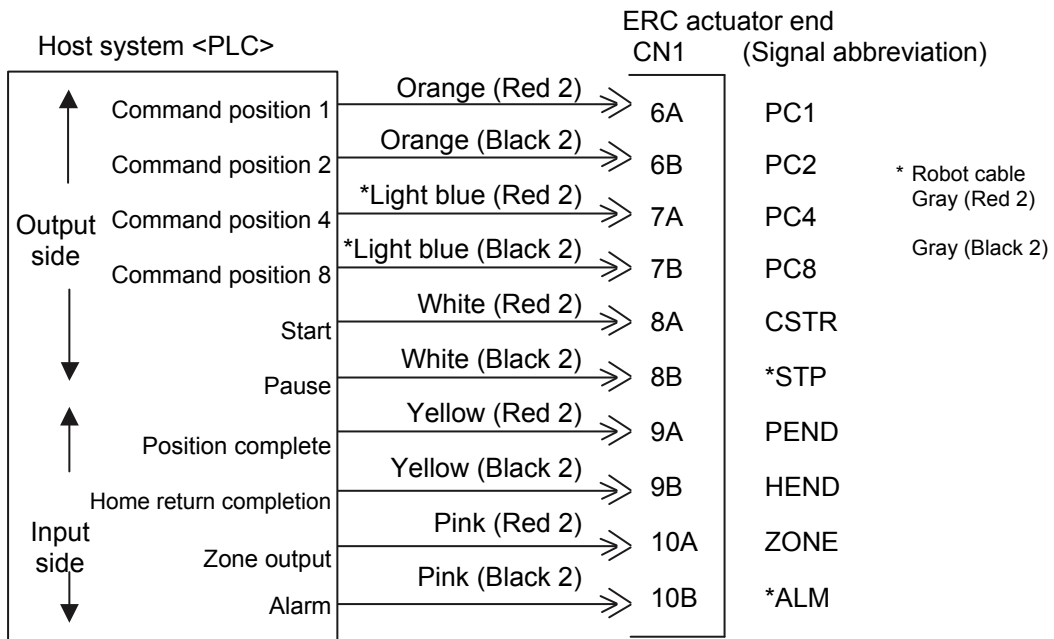

(Note) *STP and *ALM are always ON.

3.4.1 Explanation of I/O Signals

The following explains the signals used in the “8 points” and “16 points” patterns.

Category	Signal name	Signal abbreviation	Function overview
Input	Start	CSTR	Movement of the actuator starts at the rise edge of this signal.
	Command position number	PC1 PC2 PC4 PC8	This signal is used to input a position number that specifies movement. Be sure to set a command position number by 6 ms before the start signal (CSTR) is turned ON.
	*Pause	*STP	ON: The actuator can be moved, OFF: The actuator decelerates to a stop
	Home return	HOME	Home return starts at the rise edge of this signal.
Output	Position complete	PEND	This signal turns ON when the actuator has moved close enough to the target position and entered the in-position band. Used to determine if positioning has completed.
	Home return completion	HEND	This signal turns OFF when the power is input, and turns ON when home return completes.
	Zone	ZONE	This signal is output if the current actuator position is within the range set by the parameter upon completion of home return. Used as a limit switch for an intermediate point or a simple ruler for push & hold operation.
	*Alarm	*ALM	This signal remains ON while the controller is operating properly, and turns OFF when an alarm generates. The *ALM signal is synchronized with the green/red indication of the LED. (Note) The signal remains ON while the motor drive power is cut off.

3.4.2 Details of Input Signals

The input signals from this controller have an input time constant, in order to prevent malfunction caused by chattering, noise, etc.

Each input signal will switch the applicable setting when received continuously for 6 msec or more.

In other words, when a given input is switched from OFF to ON, the controller will recognize the ON state of the signal only after elapse of 6 msec.

The same applies to the switching of an input from ON to OFF. (Fig. 1)

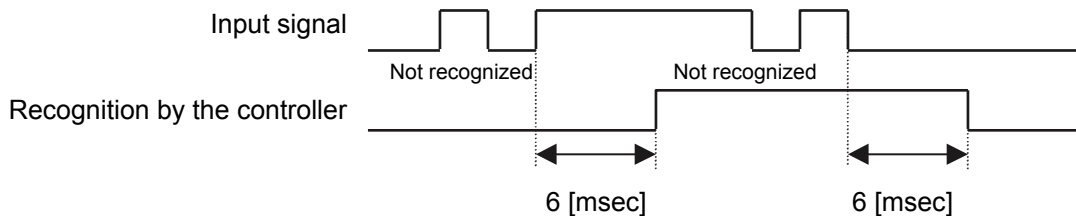

Fig. 1 Recognition of Input Signal

■ Start (CSTR)

When the OFF → ON rise edge of this signal is detected, the controller will read the target point number as the 3-bit binary code consisting of signals PC1 to PC4 (or 4-bit code consisting of signals PC1 to PC8 if the “16 points” pattern is selected), and perform positioning to the target position specified by the corresponding position data.

Before executing a command using the start signal, make sure the target position, speed and other operation data are set in the position table using a PC or teaching pendant.

If a start command is issued when the first home return is not yet completed after the power was input, home return will be performed automatically to establish the coordinates, after which the actuator will move to the target position.

■ Command position number (PC1 to PC8)

When a movement command is effected upon OFF → ON of the start signal, the four-bit binary code consisting of signals PC1 to PC8 will be read as the command position number.

(Conventional type: 3-bit code consisting of signals PC1 to PC4)

The weight of each bit is as follows: 2^0 for PC1, 2^1 for PC2, 2^2 for PC4, and 2^3 for PC8. A desired position number from 0 to 16 (maximum) can be specified.

■ Pause (*STP)

When this signal turns OFF while the actuator is moving, the actuator will decelerate to a stop.

The remaining movement is retained and will be resumed when the signal is turned ON again.

The *STP signal can be used for the following purposes:

- [1] Provide a low-level safety measure to stop the axis while the servo is ON, such as a sensor that detects a person approaching the system
- [2] Prevent contact with other equipment
- [3] Perform positioning based on sensor or LS detection

(Note) If the *STP signal is input while the actuator is performing home return, the movement command will be retained if the actuator is yet to contact a mechanical end. If the signal is input after the actuator has reversed upon contacting a mechanical end, home return will be performed again from the beginning.

■ Home return (HOME)

The controller will start home return operation upon detection of an OFF → ON edge of this signal.

When the home return is complete, the HEND signal will be output. The HOME signal can be input as many times as required.

(Note) The HOME signal is not an absolute requirement, because even if home return has not yet been performed after the power was input, the controller will automatically perform home return operation before positioning to the target position.

3.4.3 Details of Output Signals

■ Position complete (PEND)

This signal indicates that the target position was reached and positioning has completed.

When the controller becomes ready after the power was input and the servo has turned ON, this signal will turn ON if the position deviation is within the in-position band.

Then, when a movement command is issued by turning ON the start signal, the PEND signal will turn OFF. It will turn ON again when the deviation from the target position falls within the in-position band.

Once turned ON, the PEND signal will not turn OFF even when the position deviation subsequently exceeds the in-position range.

(Note) If the start signal remains ON, the PEND signal will not turn OFF even when the deviation from the target position falls within the in-position range: it will turn ON when the start signal turns OFF. Even when the motor is stopped, the PEND signal will remain OFF if the pause signal is input or the servo is OFF.

■ Home return completion (HEND)

This signal is OFF immediately after the power is input, and turns ON in either of the following two conditions:

- [1] Home return operation has completed with respect to the first movement command issued with the start signal.
- [2] Home return operation has completed following an input of the home return signal.

Once turned ON, this signal will not turn OFF until the input power is cut off or the home return signal is input again.

The HEND signal can be used for the following purposes:

- [1] Check prior to establishing the home if movement toward the home direction is permitted, in cases where an obstacle is located in the direction of the home
- [2] Use as a condition for enabling the zone output signal

■ Zone (ZONE)

Use a ZONE signal as a limit switch at an intermediate point or as a simple ruler.

This signal will turn ON when the current position is inside the range specified by parameter Nos. 1 and 2, and turn OFF if the current position is outside this range.

(Note) The ZONE signal is enabled after the coordinate system is established following a completion of home return. It will not be output simply by turning on the power.

As long as home return has completed, the ZONE signal remains enabled while the motor drive power is cut off.

■ Alarm (*ALM)

This signal remains ON while the controller is operating properly, and turns OFF when an alarm has generated. Provide an appropriate safety measure for the entire system by allowing the PLC to monitor the OFF status of this signal.

For details of alarms, refer to 9, “Troubleshooting.”

(Reference) Output Signal Changes in Each Mode

Mode classification	PEND	HEND
Actuator is stopped with the servo ON after the power was input	ON	OFF
Home return is in progress following an input of the home return signal	OFF	OFF
Home return has completed following an input of the home return signal	ON	ON
Actuator is moving in the positioning/push & hold mode	OFF	ON
Actuator is paused in the positioning/push & hold mode	OFF	ON
Positioning has completed in the positioning mode	ON	ON
Actuator has stopped after contacting the load in the push & hold mode	ON	ON
Actuator has stopped after missing the load (no load) in the push & hold mode	OFF	ON
Motor drive power is cut off after home return	OFF	ON

(Note) Use PEND to determine whether the actuator has stopped after contacting the load or missing the load in the push & hold mode.

3.5 Configuration Using a SIO Converter

If any of the following conditions applies, use a SIO converter to connect the teaching pendant, PC or PLC's communication module:

- [1] The actuator's rear cover cannot be reached and therefore the teaching pendant or PC cannot be connected.
- [2] Want to execute movement operation or parameter edit for all axes when multiple axes are connected to the single equipment.
- [3] Want to operate the actuator via serial communication using the PLC's communication module.

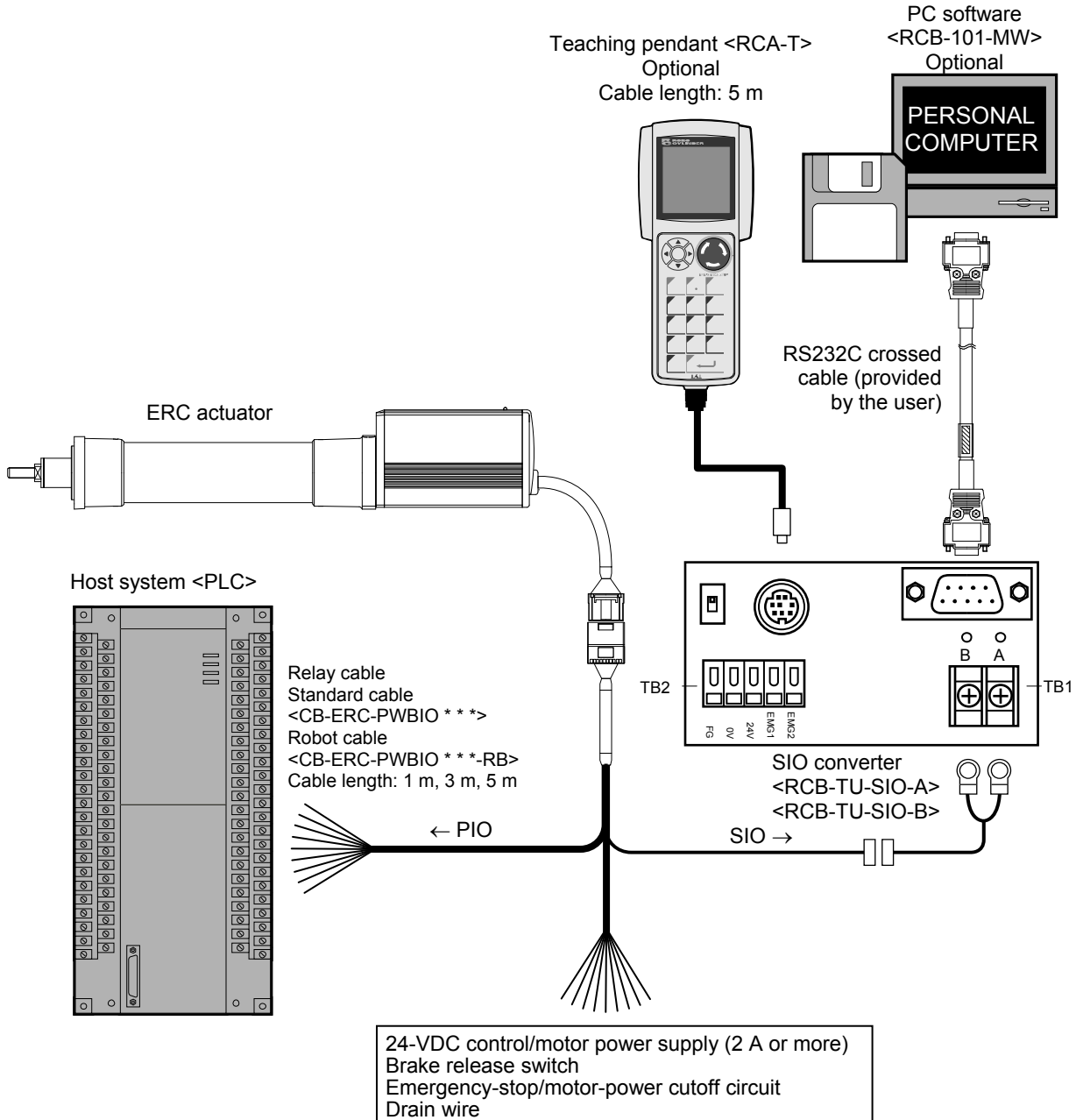

Note: Do not connect a teaching pendant and a PC at the same time. If both are connected at the same time, a communication error (message level) will occur.

● Connection diagram

[1] When the control board is of the NPN specification [sink type]

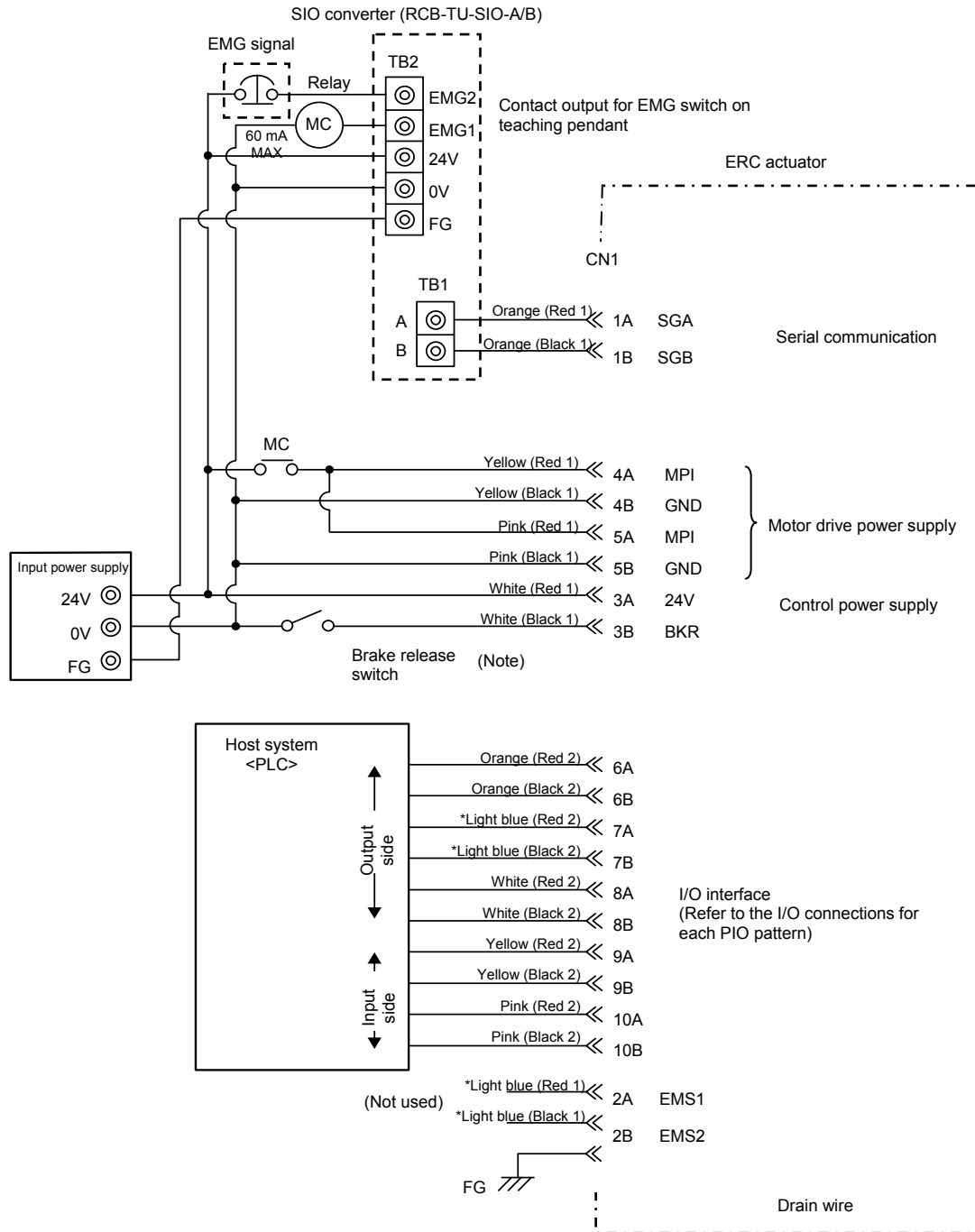

* In the case of a robot cable, the wire colors change as follows.

Wire color	Pin number
Gray (Red 1)	2A
Gray (Black 1)	2B
Gray (Red 2)	7A
Gray (Black 2)	7B

(Note) To release the brake, connect a switch between BKR and 0 V and turn on the switch.

[2] When the control board is of the PNP specification [source type]

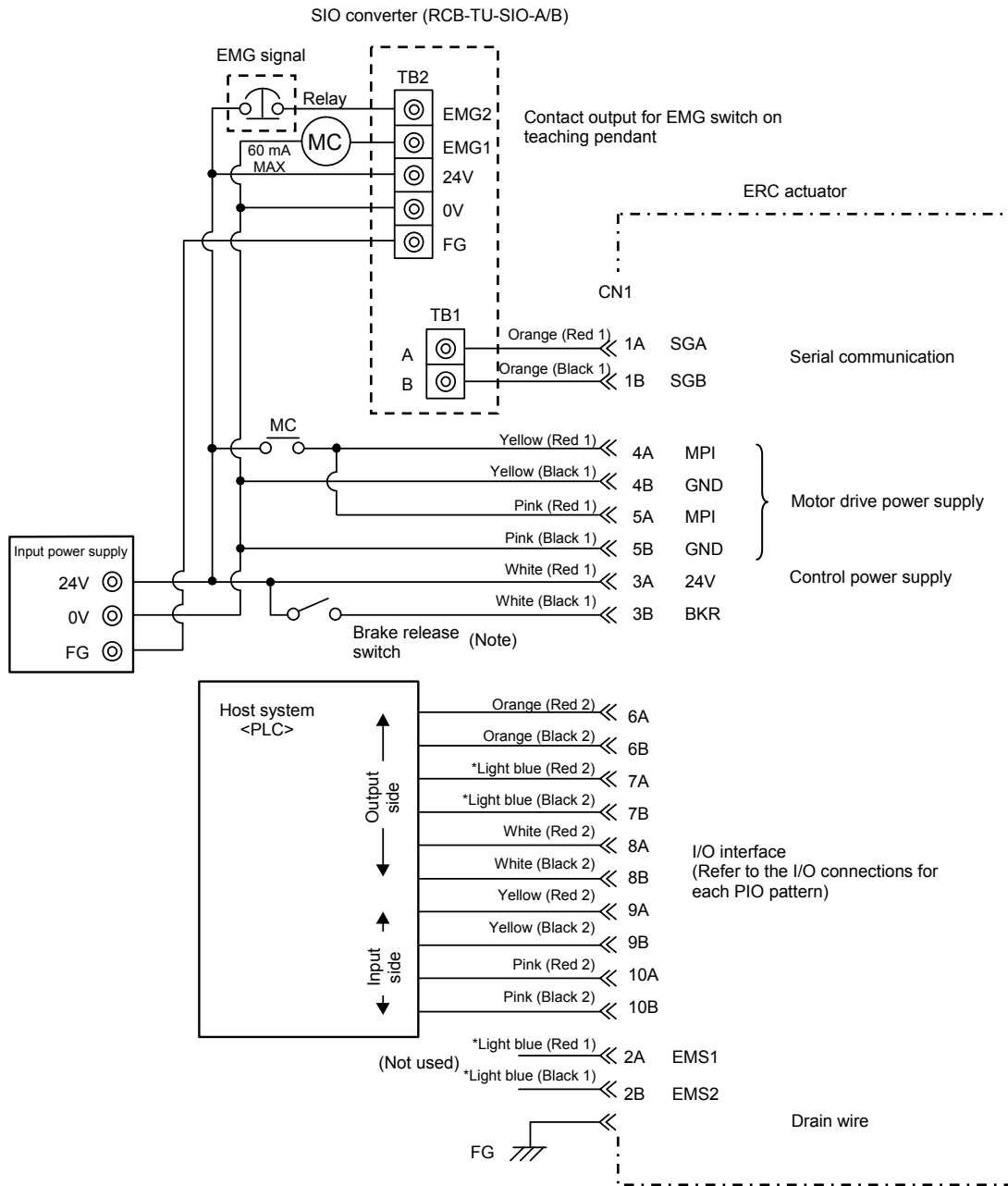

* In the case of a robot cable, the wire colors change as follows.

Wire color	Pin number
Gray (Red 1)	2A
Gray (Black 1)	2B
Gray (Red 2)	7A
Gray (Black 2)	7B

(Note) To release the brake, connect a switch between BKR and 24 V and turn on the switch.

3.6 Configuration Using an Insulated PIO Terminal Block

If either of the following conditions applies, use an insulated PIO terminal block:

- [1] Want to insulate the control power supply from the PIO power supply.
- [2] Want to change the I/O logic of the control board

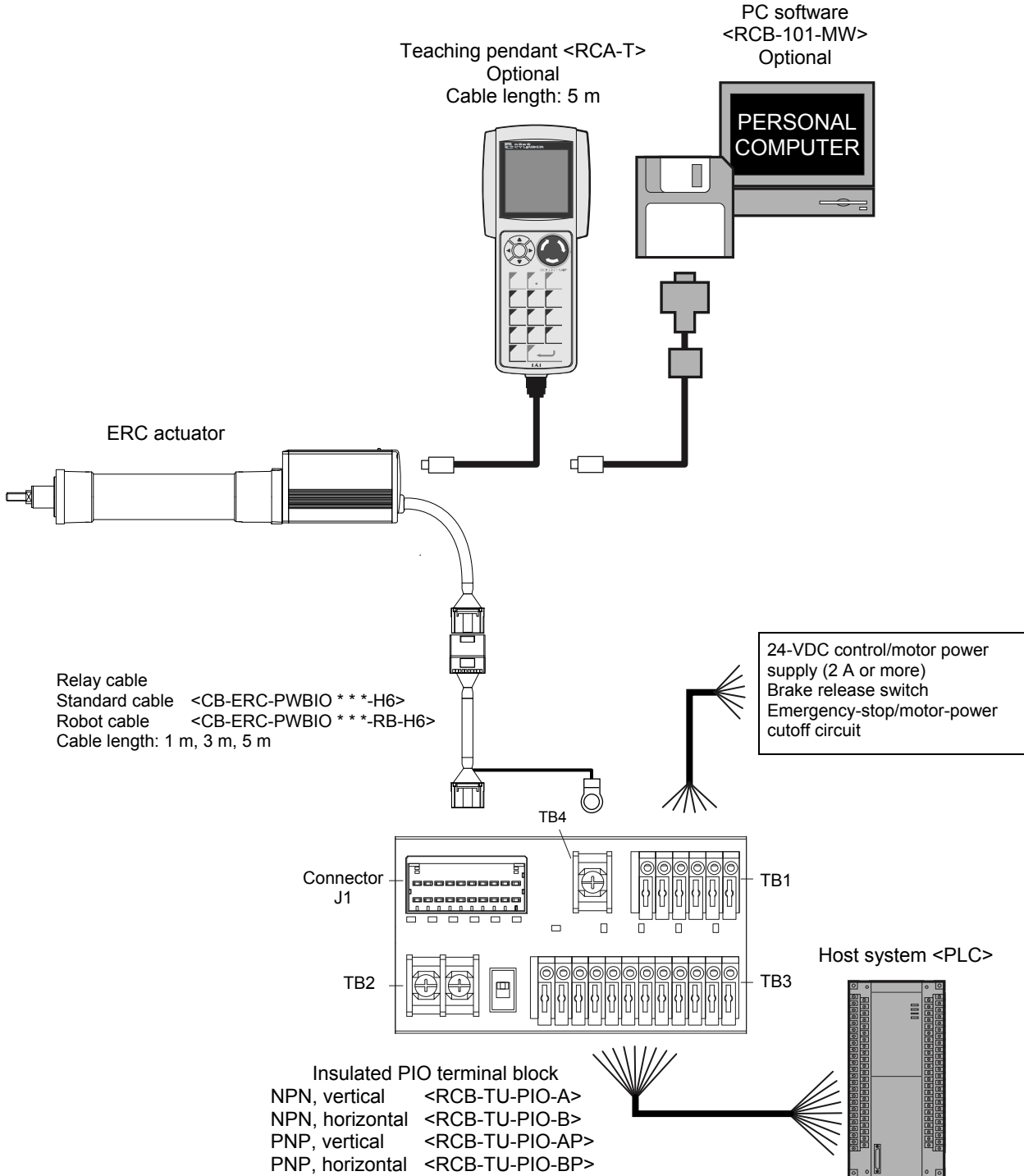

● Connection diagram

[1] When the control board is of the NPN specification [sink type]

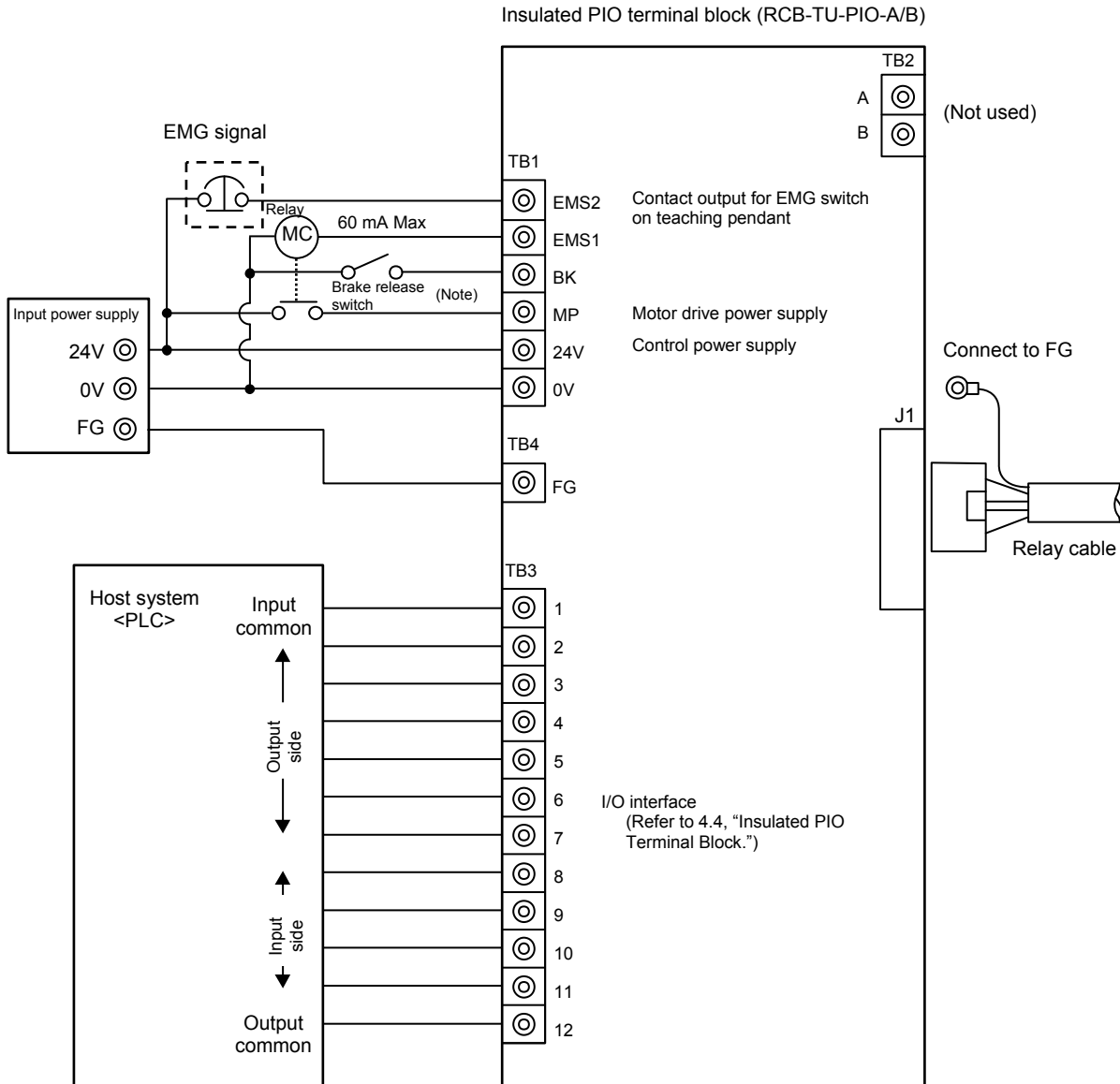

	[1] Insulate the power supply	[2] Change to PNP
Input common	24 V	0 V
Output common	0 V	24 V

(Note) To release the brake, connect a switch between the TB1-BK terminal and 0 V and turn on the switch.

[2] When the control board is of the PNP specification [source type]

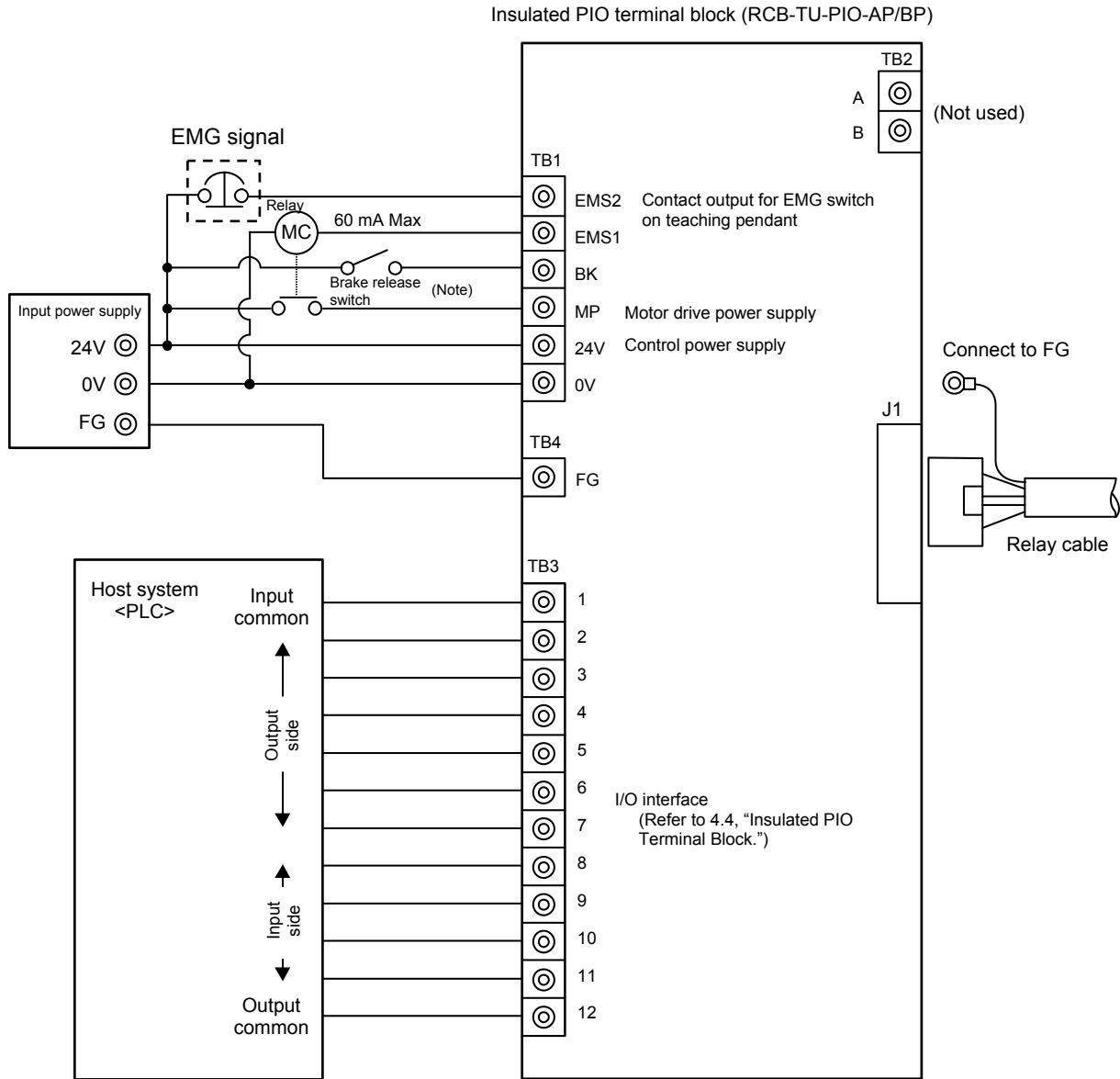

	[1] Insulate the power supply	[2] Change to NPN
Input common	0 V	24 V
Output common	24 V	0 V

(Note) To release the brake, connect a switch between the TB1-BK terminal and 24 V and turn on the switch.

RC ROBO CYLINDER

3.7 Configuration Using Both SIO Converter and Insulated PIO Terminal Block

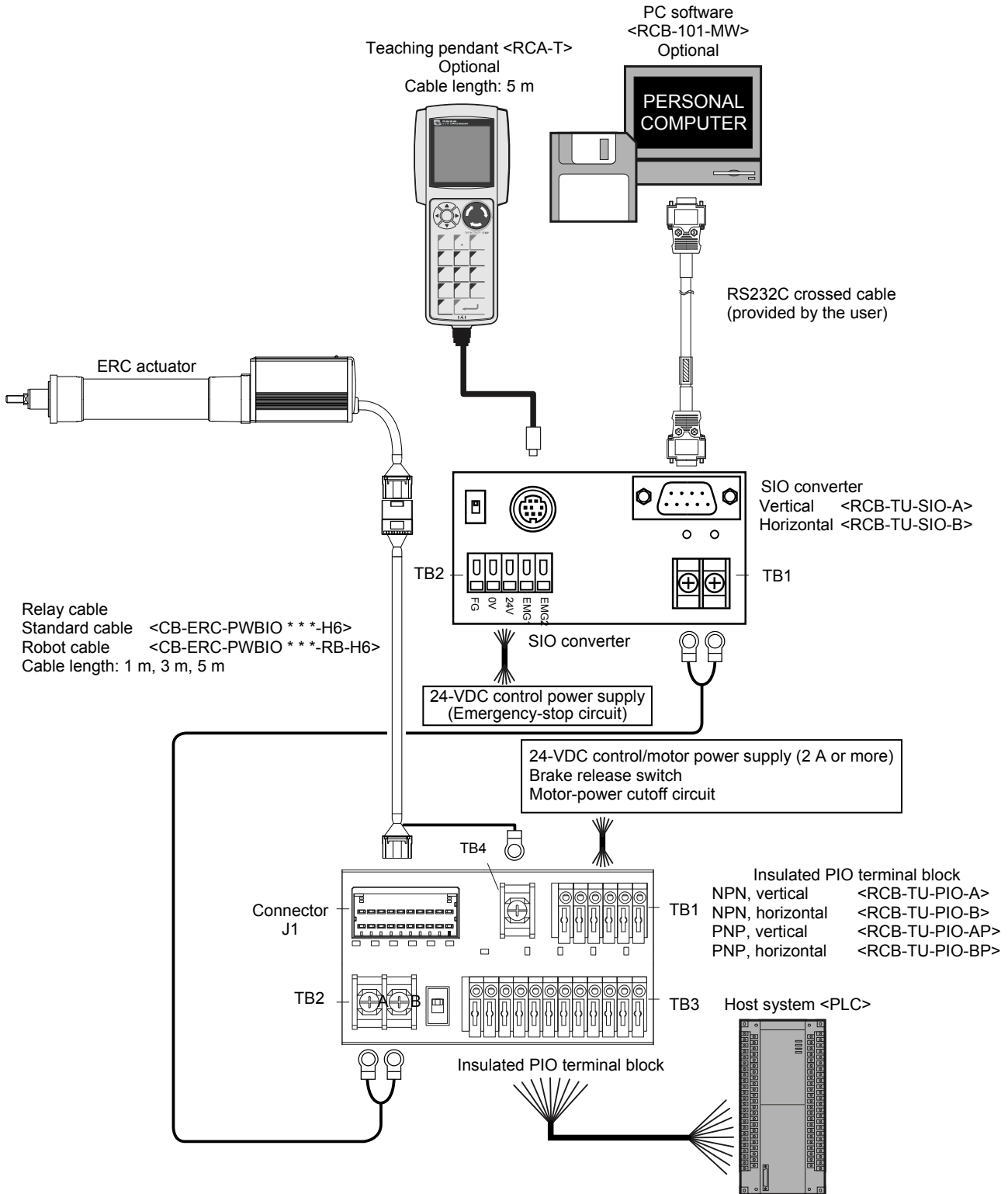

Note: Do not connect a teaching pendant and a PC at the same time. If both are connected at the same time, a communication error (message level) will occur.

● Connection diagram

[1] When the control board is of the NPN specification [sink type]

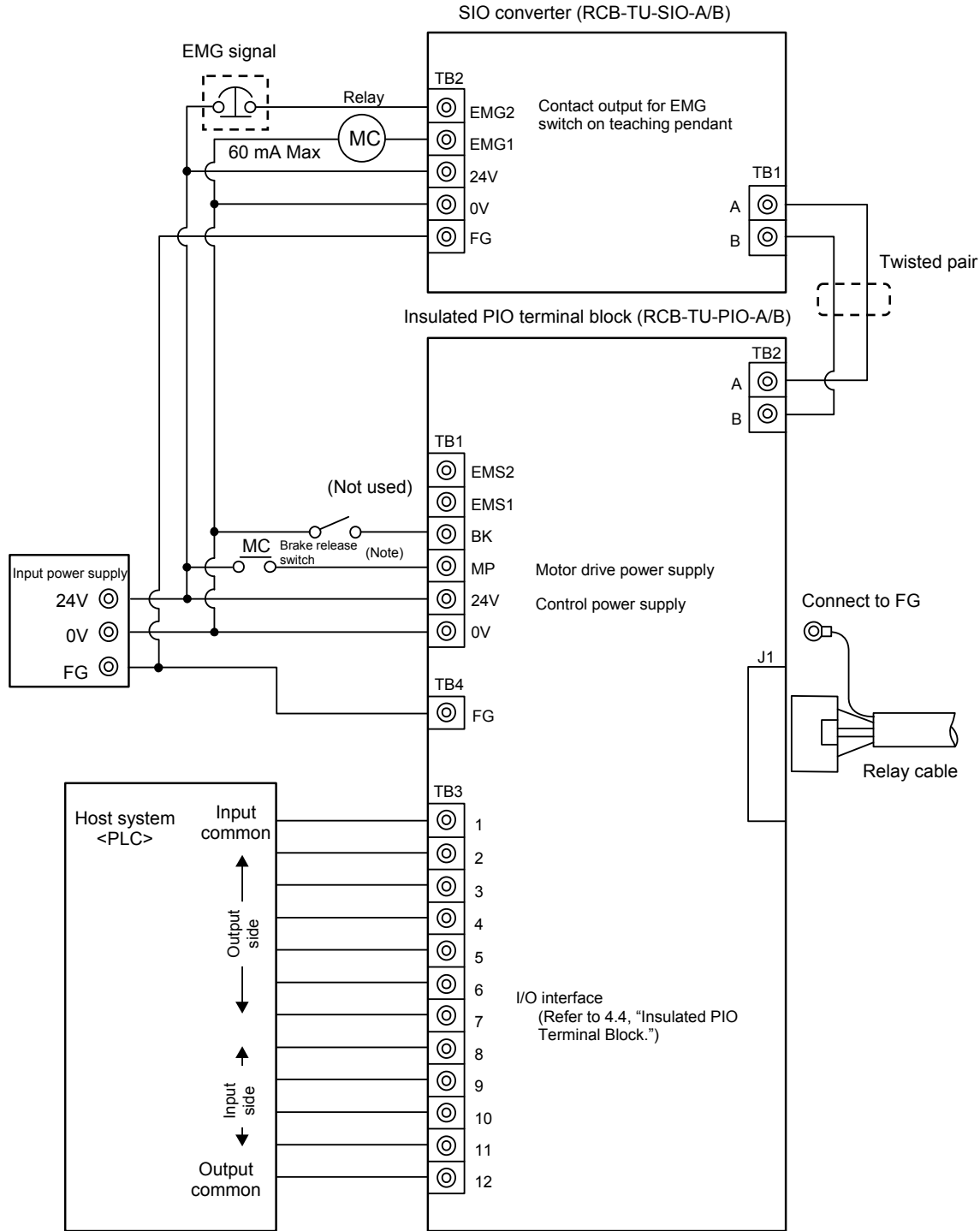

	[1] Insulate the power supply	[2] Change to PNP
Input common	24 V	0 V
Output common	0 V	24 V

(Note) To release the brake, connect a switch between the TB1-BK terminal and 0 V and turn on the switch.

[2] When the control board is of the PNP specification [source type]

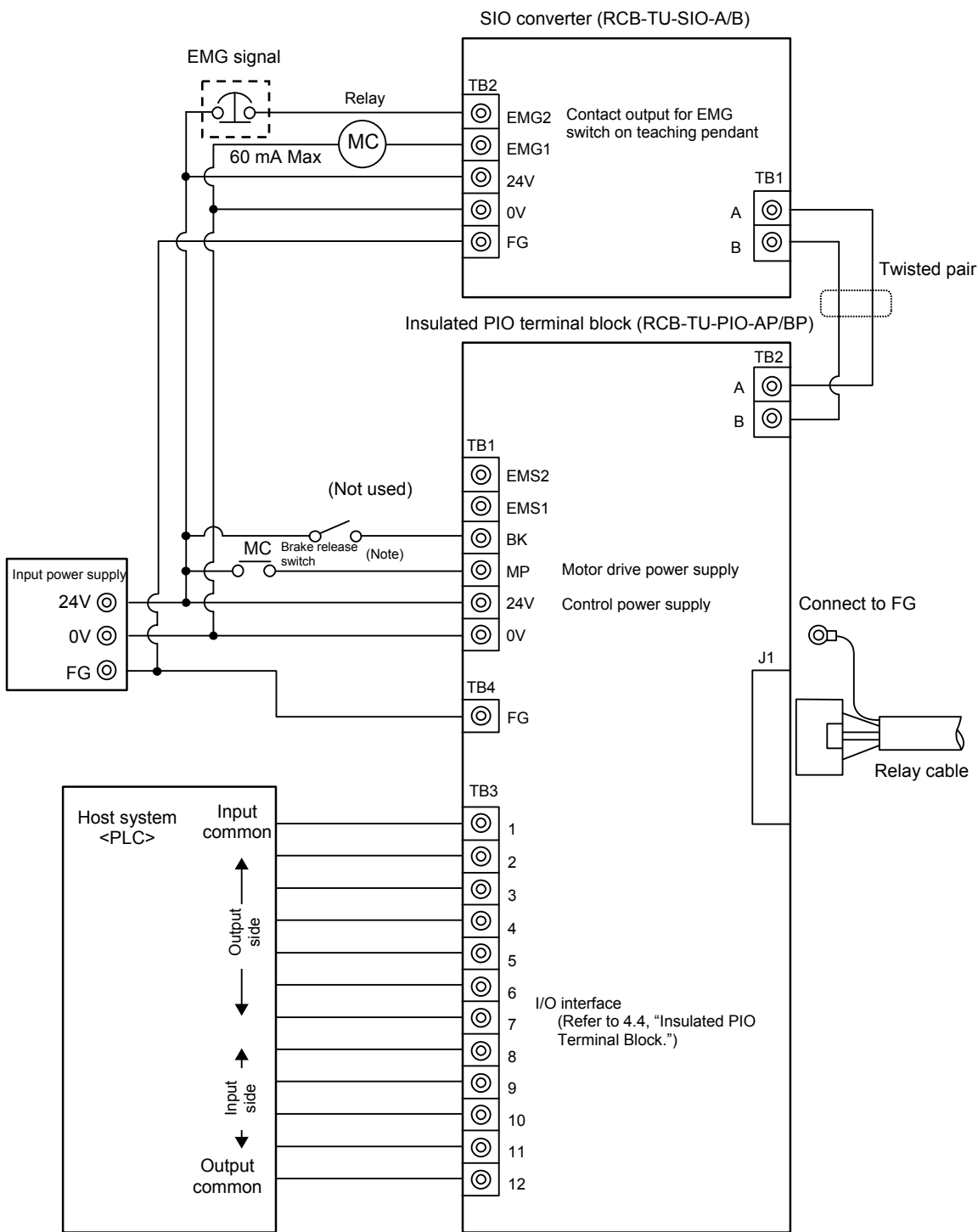

	[1] Insulate the power supply	[2] Change to NPN
Input common	0 V	24 V
Output common	24 V	0 V

(Note) To release the brake, connect a switch between the TB1-BK terminal and 24 V and turn on the switch.

3.8 Controlling Multiple Axes via Serial Communication

The following operations become possible if multiple axes are controlled:

- [1] Executing movement operations or parameter edit to all axes by connecting teaching pendant or PC via SIO converter.
- [2] Performing operations via serial communication with the PLC's communication module as a host by way of a SIO converter.

3.8.1 Basic Specifications

Specification item	Description
Communication format	RS485
Transmission speed	115200 bps (9600 bps, 19200 bps or 38400 bps may also be selected)
Maximum number of units that can be connected	16 axes
Maximum cable length	100 m or less
Terminal resistor	120 Ω (built into the SIO converter/insulated PIO terminal block); required if the cable length is 10 m or more.

3.8.2 Address Assignment

In a linked configuration where multiple axes are connected via serial communication, the host (teaching pendant, PC or communication module) assigns an address to each axis in order to recognize the corresponding actuator.

Assign addresses in the setting screen of the teaching pendant or PC.

- Overview of operation on the PC
 - [1] Open the main window → [2] Click **Setup (S)** → [3] Bring the cursor to **Controller Setup (C)** → [4] Bring the cursor to **Assign Address (N)** and click the mouse → [5] Enter an appropriate number in the address table.
- Overview of operation on the teaching pendant RCA-T
 - [1] Open the User Adjustment screen → [2] Use the ► key to bring the cursor to **Address No.** → [3] Enter an appropriate address and press the ENTER key → [4] Enter "2" under **Adjustment No.** and press the ENTER key → [5] Restart the actuator.
- Overview of operation on the simple teaching pendant RCA-E
 - [1] Open the User Adjustment screen → [2] Press the ENTER key to open the screen showing **Address No.** → [3] Enter an appropriate address and press the ENTER key → [4] Enter "2" under **Adjustment No.** and press the ENTER key → [5] Restart the actuator.
- Overview of operation on the jog teacher RCB-J
 - [1] Press the ON/OFF and RUN keys together to turn on the power → [2] Press the – key to open the screen showing **Axis No.** → [3] Use the + and – keys to set an appropriate address → [4] Press the SET key → [5] Restart the actuator.

Refer to the operation manual for the teaching pendant or PC software for the specific operating procedure.

In the actual process of assigning addresses, the teaching pendant or PC and the target actuator must have a one-on-one link. Therefore, disconnect the communication cables (SGA/SGB) from other axes to tentatively provide a condition where not more than one axis is connected.

3.8.3 Wiring Examples for Linking Multiple Axes

- Using only a SIO converter
(The same wiring applies to a configuration for automatic operation via serial communication.)

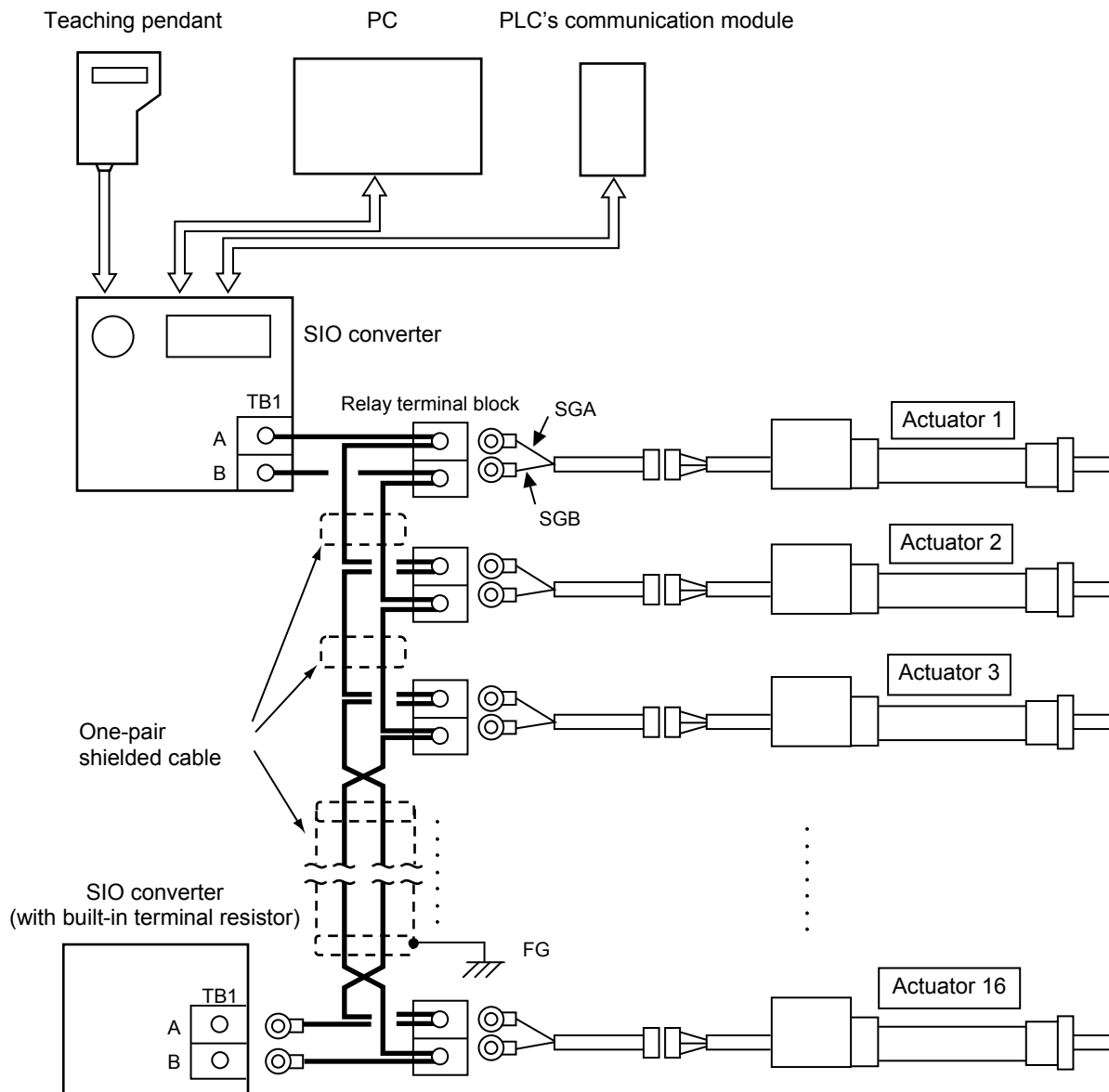

- (Note 1) If a communication error occurs when the overall length of communication cable is 10 m or more, connect a SIO converter to the last axis.
- (Note 2) If the actuators use different power supplies, align 0 [V] on all power supplies.
- (Note 3) Connect the shielded wire of each axis to FG.
- (Note 4) If the overall length of link cable exceeds 30 m, use wire of 22AWG or larger size.

- Using both SIO converter and insulated PIO terminal block
(Communication with the PLC is performed via parallel I/O connection.)

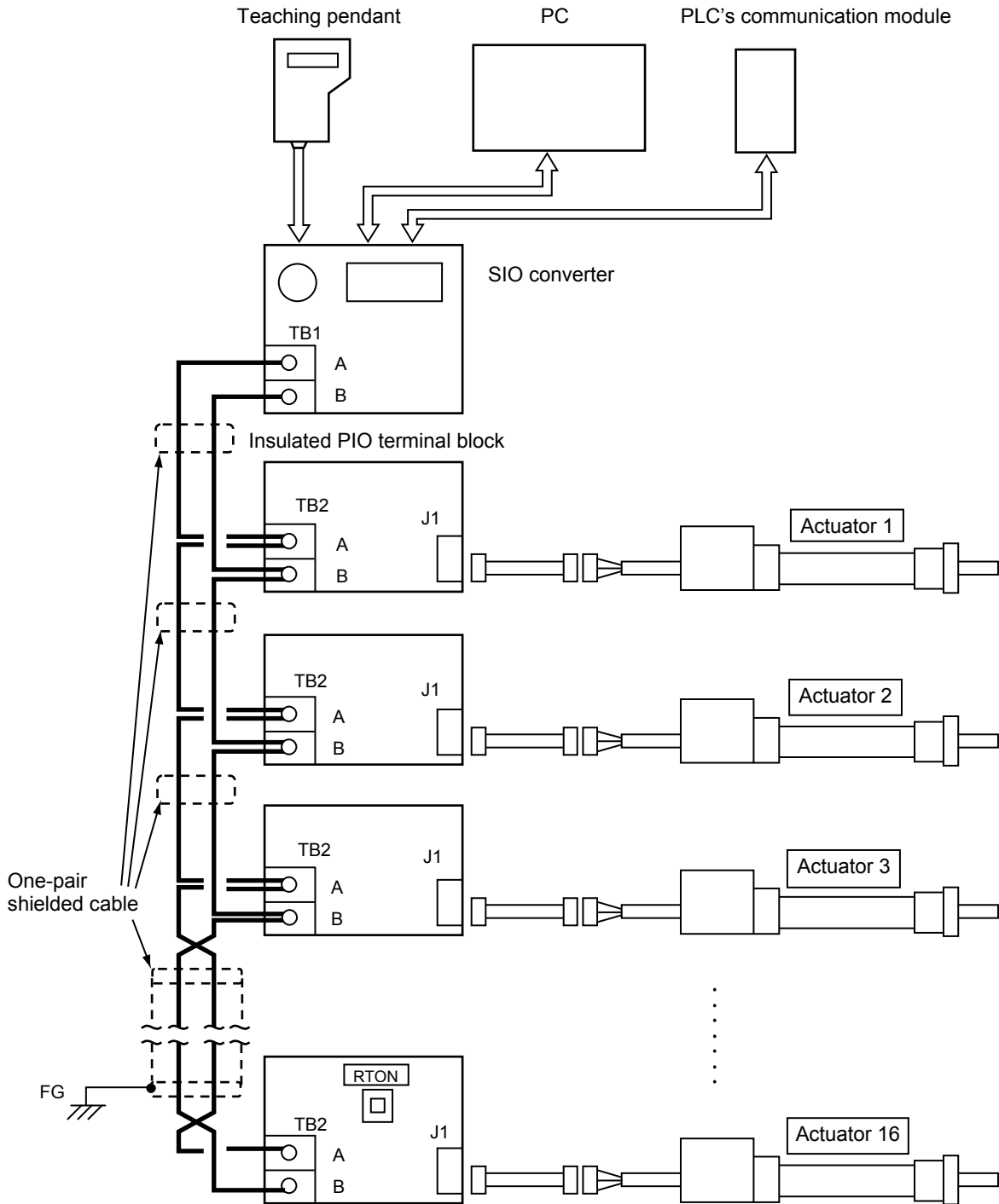

- | | |
|----------|---|
| (Note 1) | Only on the last axis set the terminal-resistor connection switch to the [RTON] side. |
| (Note 2) | If the actuators use different power supplies, align 0 [V] on all power supplies. |
| (Note 3) | Connect the shielded wire of each axis to FG. |
| (Note 4) | If the overall length of link cable exceeds 30 m, use wire of 22AWG or larger size. |

3.9 Emergency-Stop Circuit

Examples of internal circuit and recommended circuit are shown below.

For auxiliary relays, use relays with a diode for absorbing coil surge.

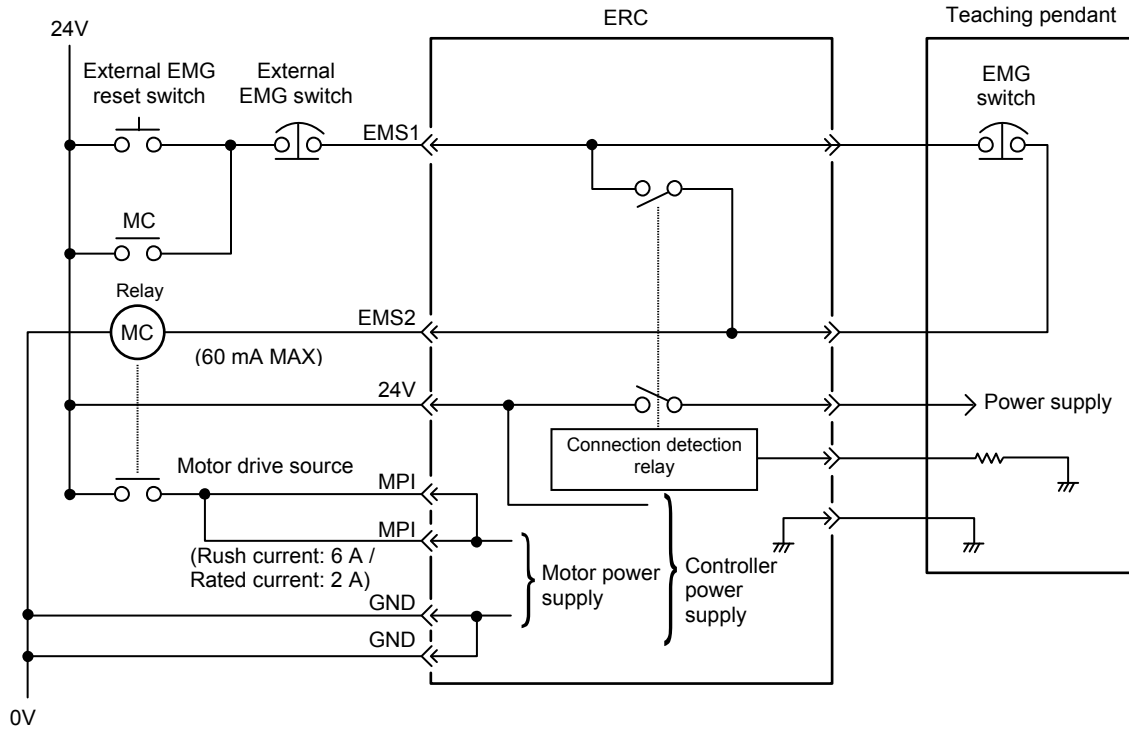

[Reference] Recommended relays are listed below. Use this information as a reference when selecting a relay.

Manufacturer	Product name
Omron	LY Series
Panasonic	HC Relay Series

For the detailed specifications of each product, check the specification sheet issued by the manufacturer.

- Example of multi-axes circuit allowing each axis to be connected/disconnected to the teaching pendant

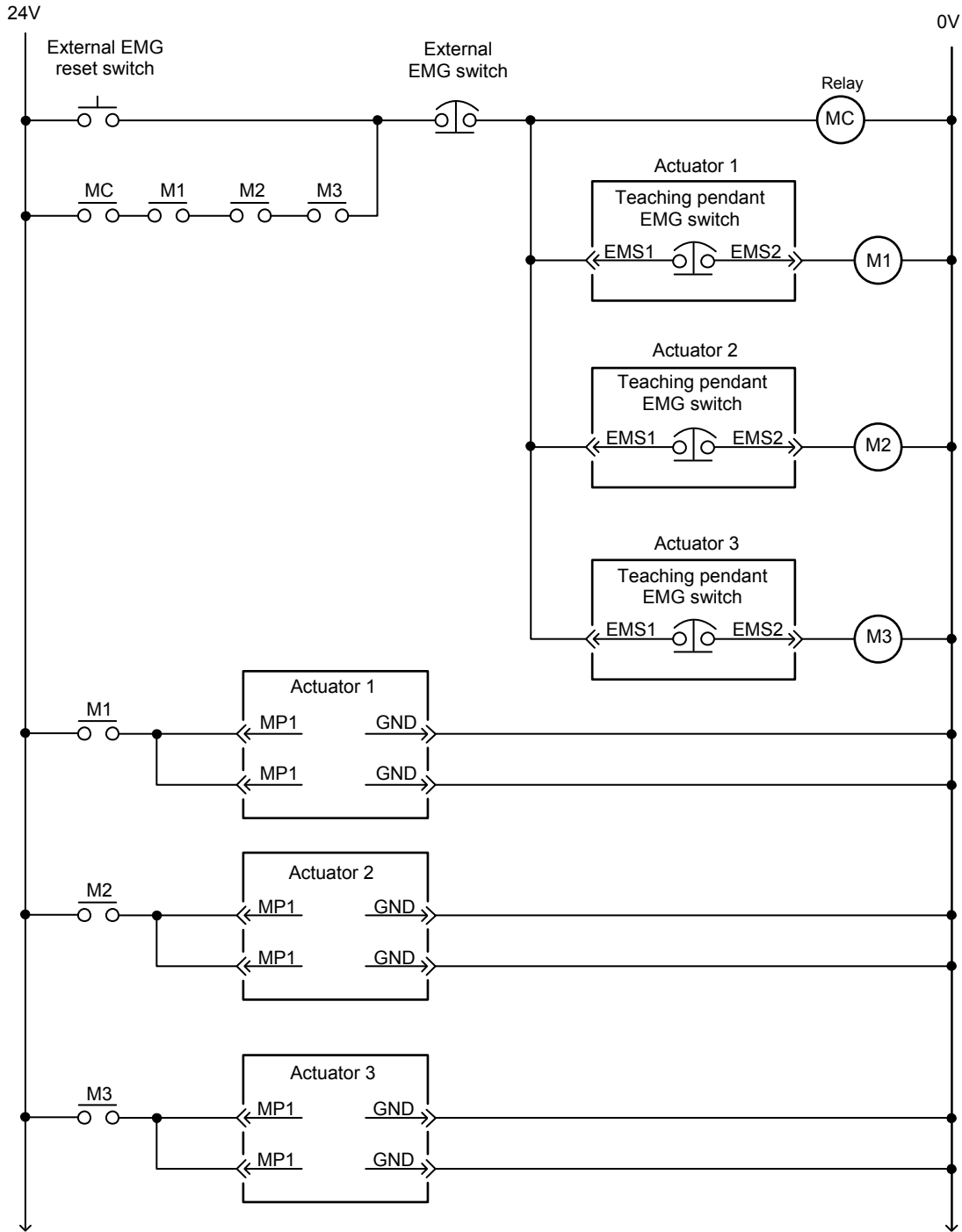

3.10 Relay Cable

- No connector on the counter-actuator end (When connecting the actuator directly to a host system)

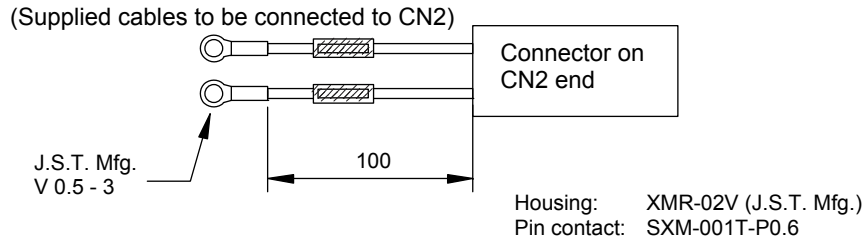
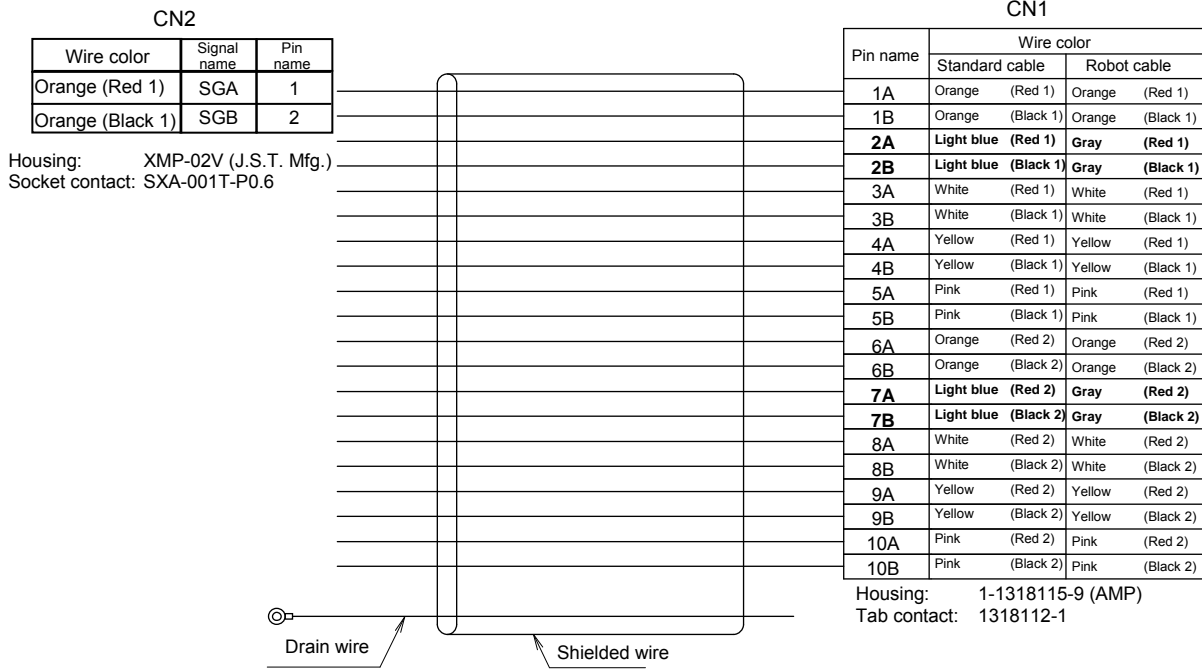
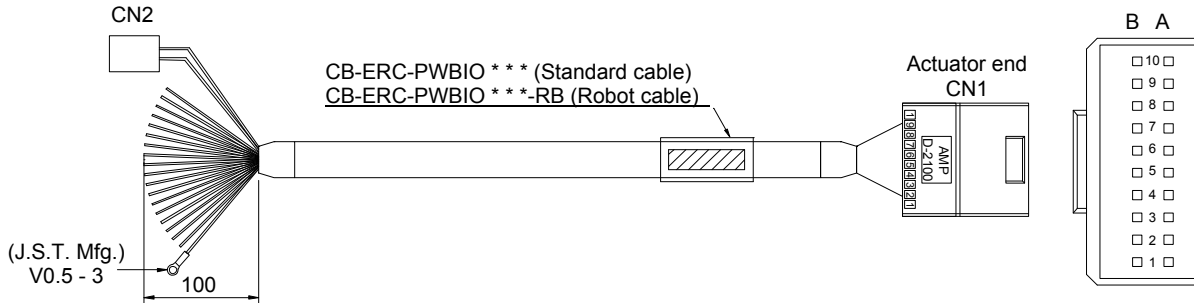

Wire color	Signal name	Pin name
Red	SGA	1
Black	SGB	2

(Note) Connecting 24V to the SGA/SGB serial-communication lines will cause a breakdown. To prevent miswiring, a two-pin connector is installed at the ends of the applicable lines. If multiple axes are linked, connect these supplied cables to the CN2 connector and extend as required, or cut them off at the base of the CN2 connector and install crimp terminals directly.

- Connectors on both ends (When using an insulated PIO terminal block)

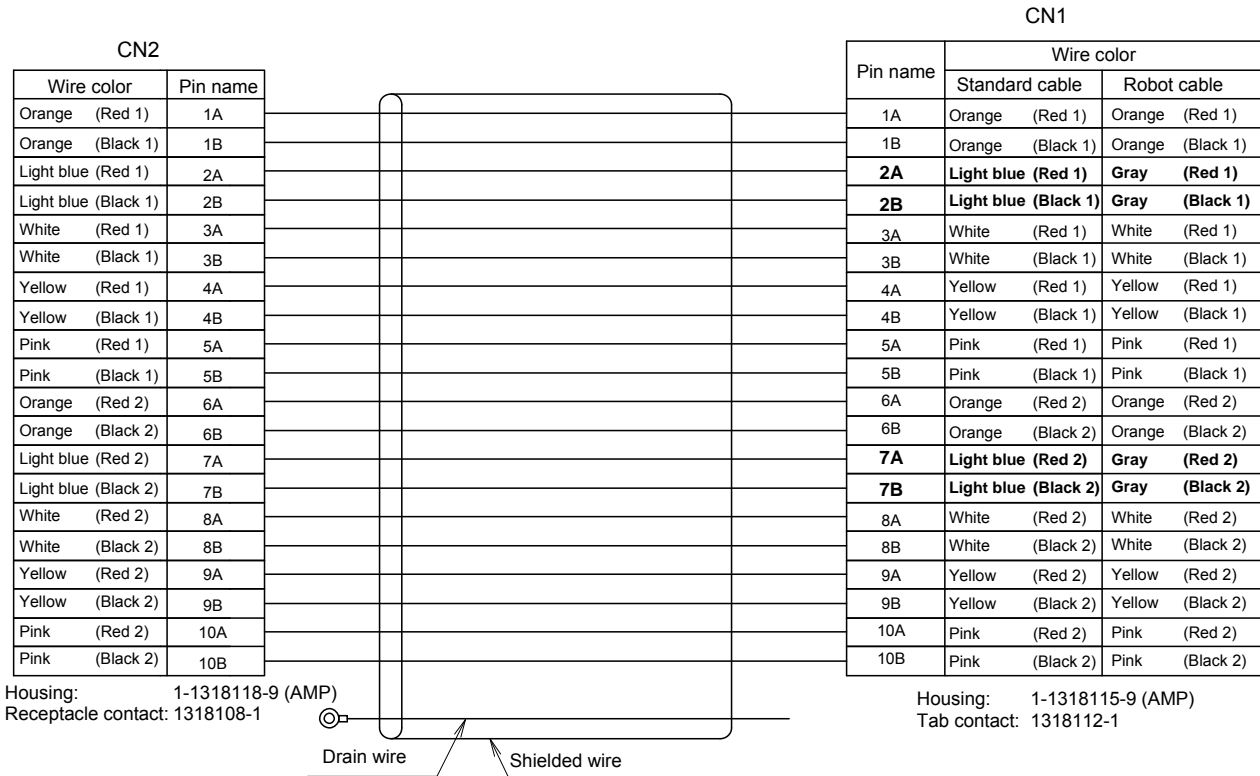
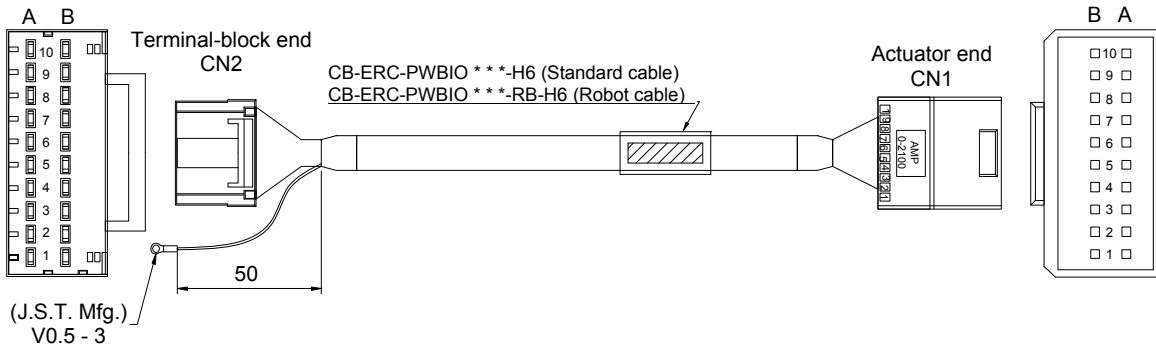

4. Electrical Specifications

4.1 Controller

Specification item		Description
Number of controlled axes		1 axis/unit
Supply voltage		24 VDC \pm 10%
Supply current		2 A max.
Control method		Weak field-magnet vector control (patent pending)
Positioning command		Position number specification
Position number		Maximum 16 points
Backup memory		Position number data and parameters are saved in nonvolatile memory. Serial EEPROM can be rewritten 100,000 times.
PIO		6 dedicated inputs/4 dedicated outputs
LED indicator		Servo ON (green)/Alarm (red)
Communication		RS485 1 channel (terminated externally)
Electromagnetic brake Release		The user must provide a selector switch. (Current consumption: 0.15A max.)
Relay cable length		10 m or less
Insulation strength		500 VDC, 10 M Ω
Environment	Operating temperature	0 to 40°C
	Operating humidity	85%RH or less (non-condensing)
	Operating environment	No contact with corrosive gases.
	Storage temperature	-10 to 65°C
	Storage humidity	90%RH or less (non-condensing)
	Vibration resistance	10 to 57 Hz in XYZ directions / Pulsating amplitude: 0.035 mm (continuous), 0.075 mm (intermittent)
	Protection class	IP20
Weight		Approx. 32 g
External dimensions		109 W x 40 D (mm), printed circuit board

4.2 I/O Signal Interface Circuit

4.2.1 External Input Specifications

Item	Specification
Number of input points	6 points
Input voltage	24 VDC \pm 10%
Input current	4 mA/point
Leak current	1 mA/point or less
Operating voltage	ON voltage: 18 V min. (3.5 mA) OFF voltage: 6 V max. (1 mA)

[NPN specification]

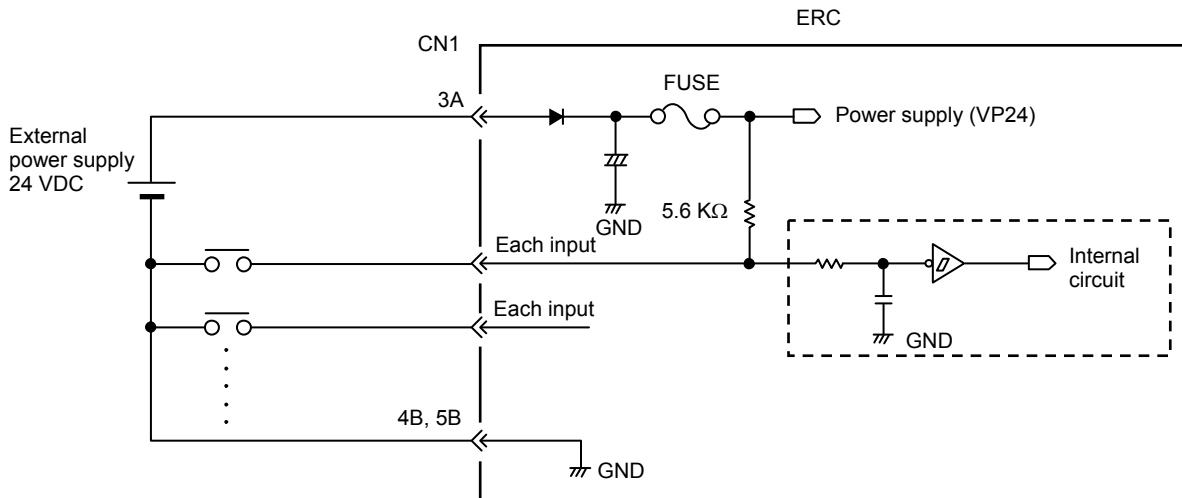

[PNP specification]

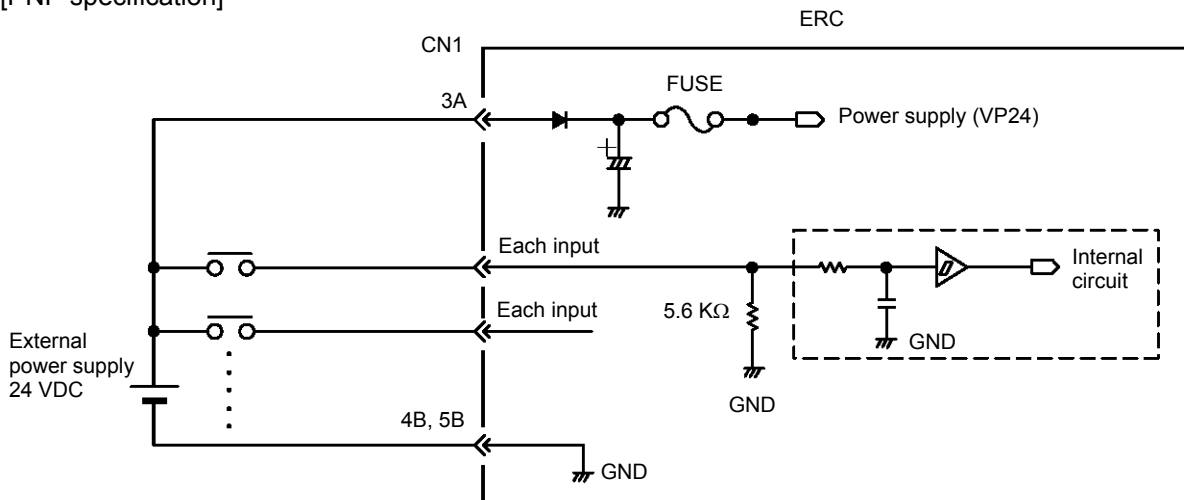

4.2.2 External Output Specifications

Item	Specification
Number of output points	4 points
Rated load voltage	24 VDC
Maximum current	60 mA/point
Residual voltage	2 V or less
Shorting/reverse-voltage protection	Fusing resistor (27 Ω, 0.1 W)

[NPN specification]

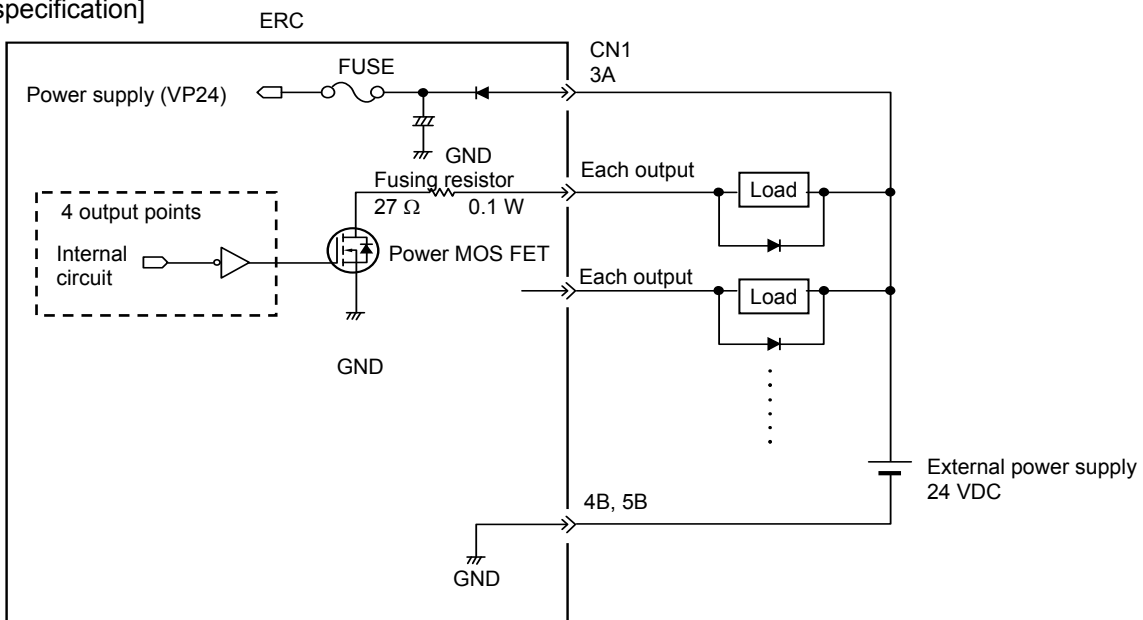

[PNP specification]

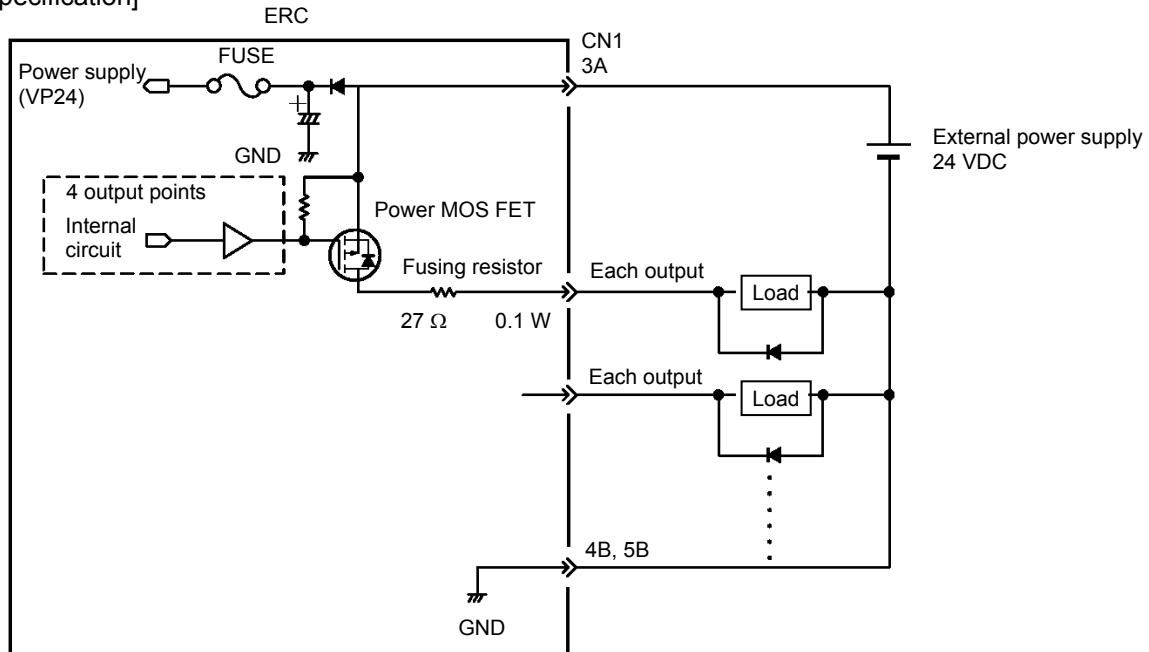

4.3 SIO Converter (Optional)

Model: RCB-TU-SIO-A (Vertical installation)
RCB-TU-SIO-B (Horizontal installation)

This unit is required if any of the following conditions applies:

- [1] The actuator's rear cover cannot be reached and therefore the teaching pendant or PC cannot be connected.
- [2] Want to execute movement operation or parameter edit for all axes when multiple axes are connected to the single equipment.
- [3] Want to operate the actuator via serial communication using the PLC's communication module.

● Explanation of functions

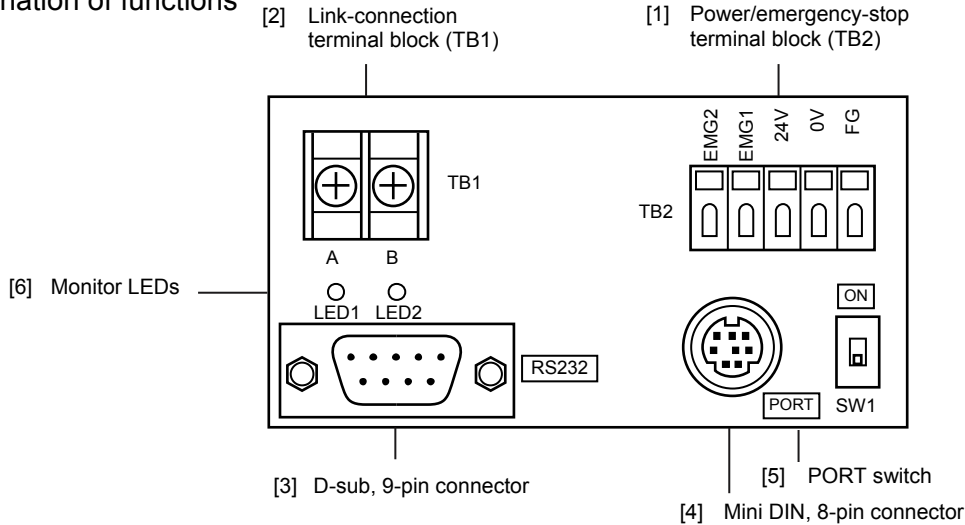

[1] Power/emergency-stop terminal block (TB2)

EMG1, EMG2	Provide a contact output for the emergency-stop switch on the teaching pendant (RCA-T/E). EMG1 and EMG2 connect to the emergency-stop switch on the teaching pendant when the PORT switch is ON, or are shorted when the PORT switch is OFF. These terminals comprise an interlock with a safety circuit provided by the user.
24V	Positive side of the 24-V power supply (Power supply for the teaching pendant and conversion circuit Current consumption: 0.1 A max.)
0V	
FG	Negative side of the 24-V power supply FG of the 24-V power supply

[2] Link-connection terminal block (TB1)

A connection port for linking the controller.

“A” on the left side connects to SGA (wire color: orange/red 1) in the relay cable or “A” on the insulated PIO terminal block TB2.

“B” on the right side connects to SGB (wire color: orange/black 1) in the relay cable or “B” on the insulated PIO terminal block TB2.

(Note) Be sure to use twisted pair wires for the above two lines (SGA/SGB).

[3] D-sub, 9-pin connector

A connection port with the host PC or PLC's communication module.

[4] Mini DIN, 8-pin connector

A connection port with the teaching pendant.

[5] PORT switch

A switch for enabling/disabling the teaching pendant.

Set the switch to ON when a teaching pendant is used, or OFF when teaching pendant is not used.

[6] Monitor LEDs

LED1 --- Lit when the controller is transmitting

LED2 --- Lit when the RS232 is transmitting

(Reference) Connection drawing of a RS232C crossed cable

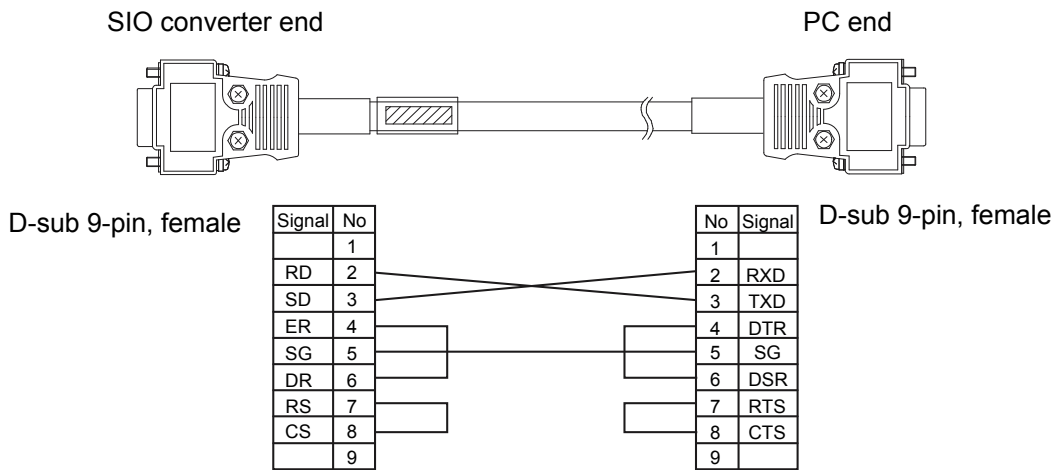

4.4 Insulated PIO Terminal Block (Optional)

- Model: RCB-TU-PIO-A (Combined with a NPN control board: Vertical installation)
 RCB-TU-PIO-B (Combined with a NPN control board: Horizontal installation)
 RCB-TU-PIO-AP (Combined with a PNP control board: Vertical installation)
 RCB-TU-PIO-BP (Combined with a PNP control board: Horizontal installation)

This unit is required if either of the following conditions applies:

- [1] Want to insulate the control power supply from the PIO power supply.
- [2] Want to change the I/O logic of the control board.
 - Control board: NPN (sink type) → Host system: PNP (source type)
 - Control board: PNP (source type) → Host system: NPN (sink type)

● Explanation of functions

[External view of RCB-TU-PIO-A/B]

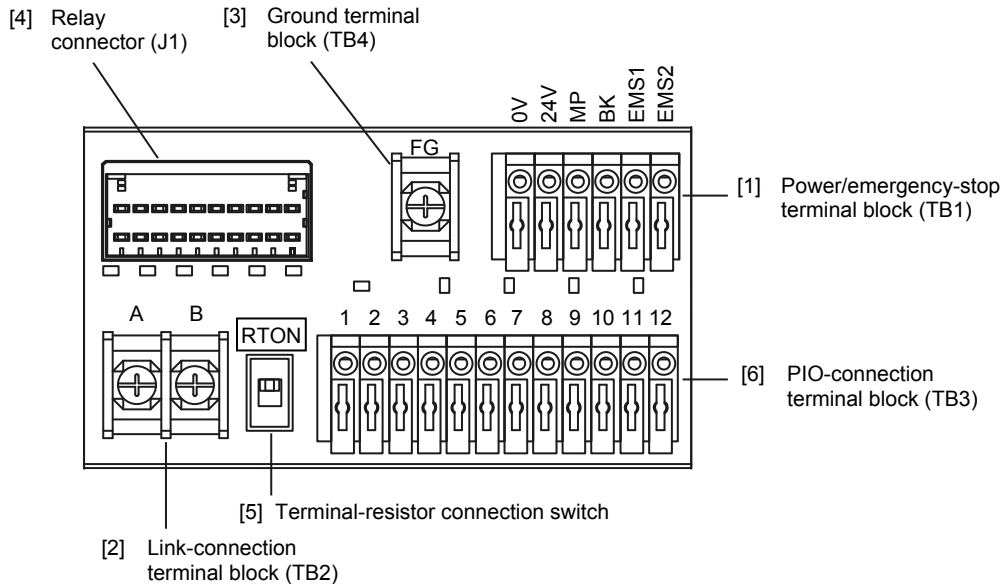

[External view of RCB-TU-PIO-AP/BP]

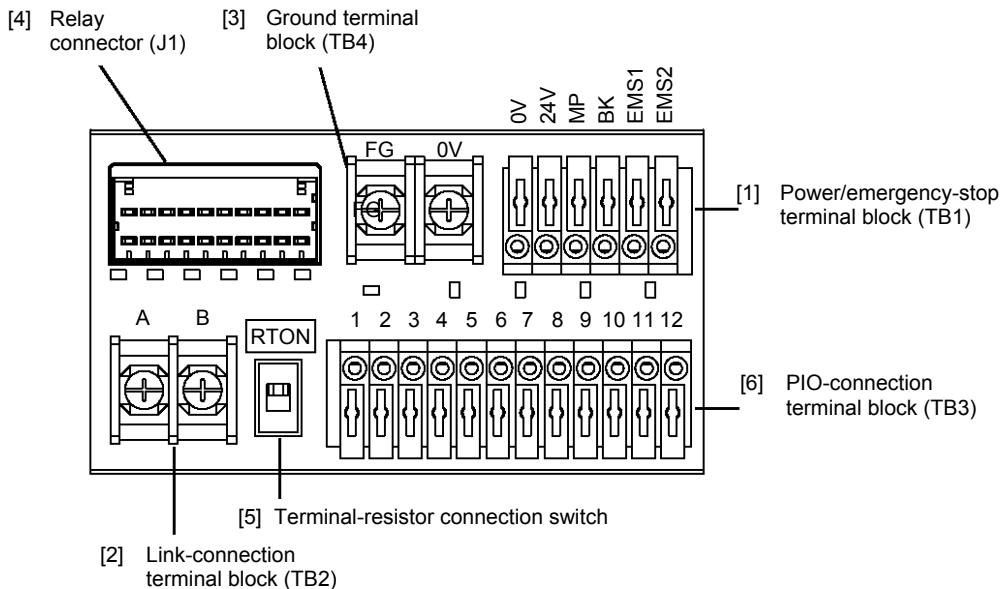

[1] Power/emergency-stop terminal block (TB1)

EMS1, EMS2	Provide a contact output for the emergency-stop switch on the teaching pendant (RCA-T/E). EMS1 and EMS2 are provided to comprise an interlock with a safety circuit provided by the user when a teaching pendant with emergency-stop switch is connected to the connector on the rear cover.
BK	Connection port for the brake release switch
MP	Motor power supply port
24V	Positive side of the 24-V control power supply
0V	Negative side of the 24-V control power supply

[2] Link-connection terminal block (TB2)

A connection port for linking a SIO converter, if used.

“A” on the left side connects to link-connection terminal block (A) on the SIO converter.

“B” on the right side connects to link-connection terminal block (B) on the SIO converter.

(Note) Be sure to use twisted pair wires for the above two lines (SGA/SGB).

[3] Frame-ground/ground terminal block (TB4)

- Frame-ground terminal (FG) . . . (1) A connection port for the relay cable’s shielded wire (drain wire).
(2) A connection port for the ground wire leading to the enclosure.
- Ground terminal (0 V) . . . Use this terminal as a relay port to connect a different power-supply line to the same grounding point.

[4] Relay connector (J1)

A connector port for the relay cable (CB-ERC-PWBIO-***-H6).

[5] Terminal-resistor connection switch

If a SIO converter is used and the link cable is long (10 m or more, as a guideline), a terminal resistor will be required to prevent signal reflection.

This unit can be used in the above application, because the TB2 terminal block has a built-in terminal resistor.

Setting the switch to the [RTON] side will connect the terminal resistor of approx. 120 Ω.

[6] PIO connection terminal block (TB3)
A PLC connection port. Detailed signal specifications are shown below.

[1] RCB-TU-PIO-A/B (When the control board is of the NPN specification)

TB3	PIO pattern			Remarks
	0 (8-point type)	1 (3-point type)	2 (16-point type)	
1	Input common (In-COM) 24 [V] (Note 1)			LED 11 illuminates when 24 V is supplied.
2	Command position 1 (PC1)	Move to rear end (ST0)	Command position 1 (PC1)	LED1 illuminates when this signal turns ON.
3	Command position 2 (PC2)	Move to front end (ST1)	Command position 2 (PC2)	LED2 illuminates when this signal turns ON.
4	Command position 4 (PC4)	Move to intermediate point (ST2)	Command position 4 (PC4)	LED3 illuminates when this signal turns ON.
5	Home return (HOME)		Command position 8 (PC8)	LED4 illuminates when this signal turns ON.
6	Start (CSTR)		Start (CSTR)	LED5 illuminates when this signal turns ON.
7	*Pause (*STP)	*Pause (*STP)	*Pause (*STP)	LED6 illuminates when this signal turns ON.
8	Position complete (PEND)	Rear end (PE0)	Position complete (PEND)	LED7 illuminates when this signal turns ON.
9	Home-return completion (HEND)	Front end (PE1)	Home-return completion (HEND)	LED8 illuminates when this signal turns ON.
10	Zone output (ZONE)	Intermediate point (PE2)	Zone output (ZONE)	LED9 illuminates when this signal turns ON.
11	*Alarm (*ALM)	*Alarm (*ALM)	*Alarm (*ALM)	LED10 illuminates when this signal turns ON.
12	Output common (Out-COM) 0 [V] (Note 1)			

(Note 1) The input common and output common become 0 [V] and 24 [V], respectively, in the PNP specification.

[2] RCB-TU-PIO-AP/BP (When the control board is of the PNP specification)

TB3	PIO pattern			Remarks
	0 (8-point type)	1 (3-point type)	2 (16-point type)	
1	Input common (In-COM) 0 [V] (Note 2)			LED 11 illuminates when 24 V is supplied.
2	Command position 1 (PC1)	Move to rear end (ST0)	Command position 1 (PC1)	LED1 illuminates when this signal turns ON.
3	Command position 2 (PC2)	Move to front end (ST1)	Command position 2 (PC2)	LED2 illuminates when this signal turns ON.
4	Command position 4 (PC4)	Move to intermediate point (ST2)	Command position 4 (PC4)	LED3 illuminates when this signal turns ON.
5	Home return (HOME)		Command position 8 (PC8)	LED4 illuminates when this signal turns ON.
6	Start (CSTR)		Start (CSTR)	LED5 illuminates when this signal turns ON.
7	*Pause (*STP)	*Pause (*STP)	*Pause (*STP)	LED6 illuminates when this signal turns ON.
8	Position complete (PEND)	Rear end (PE0)	Position complete (PEND)	LED7 illuminates when this signal turns ON.
9	Home-return completion (HEND)	Front end (PE1)	Home-return completion (HEND)	LED8 illuminates when this signal turns ON.
10	Zone output (ZONE)	Intermediate point (PE2)	Zone output (ZONE)	LED9 illuminates when this signal turns ON.
11	*Alarm (*ALM)	*Alarm (*ALM)	*Alarm (*ALM)	LED10 illuminates when this signal turns ON.
12	Output common (Out-COM) 24 [V] (Note 2)			

(Note 1) The input common and output common become 24 [V] and 0 [V], respectively, in the NPN specification.

- Internal connection diagram
- [1] RCB-TU-PIO-A/B

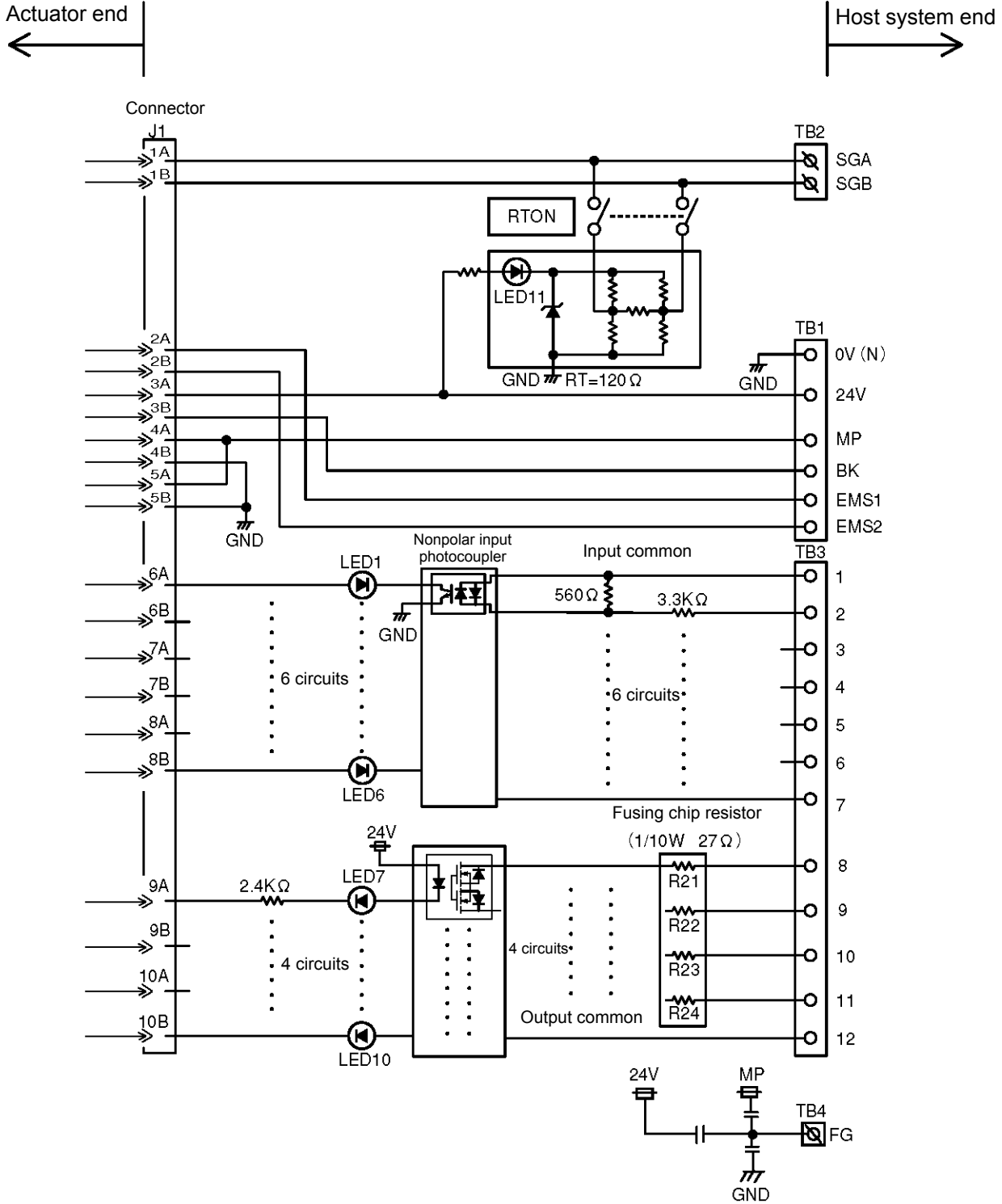

[2] PCB-TU-PIO-AP/BP

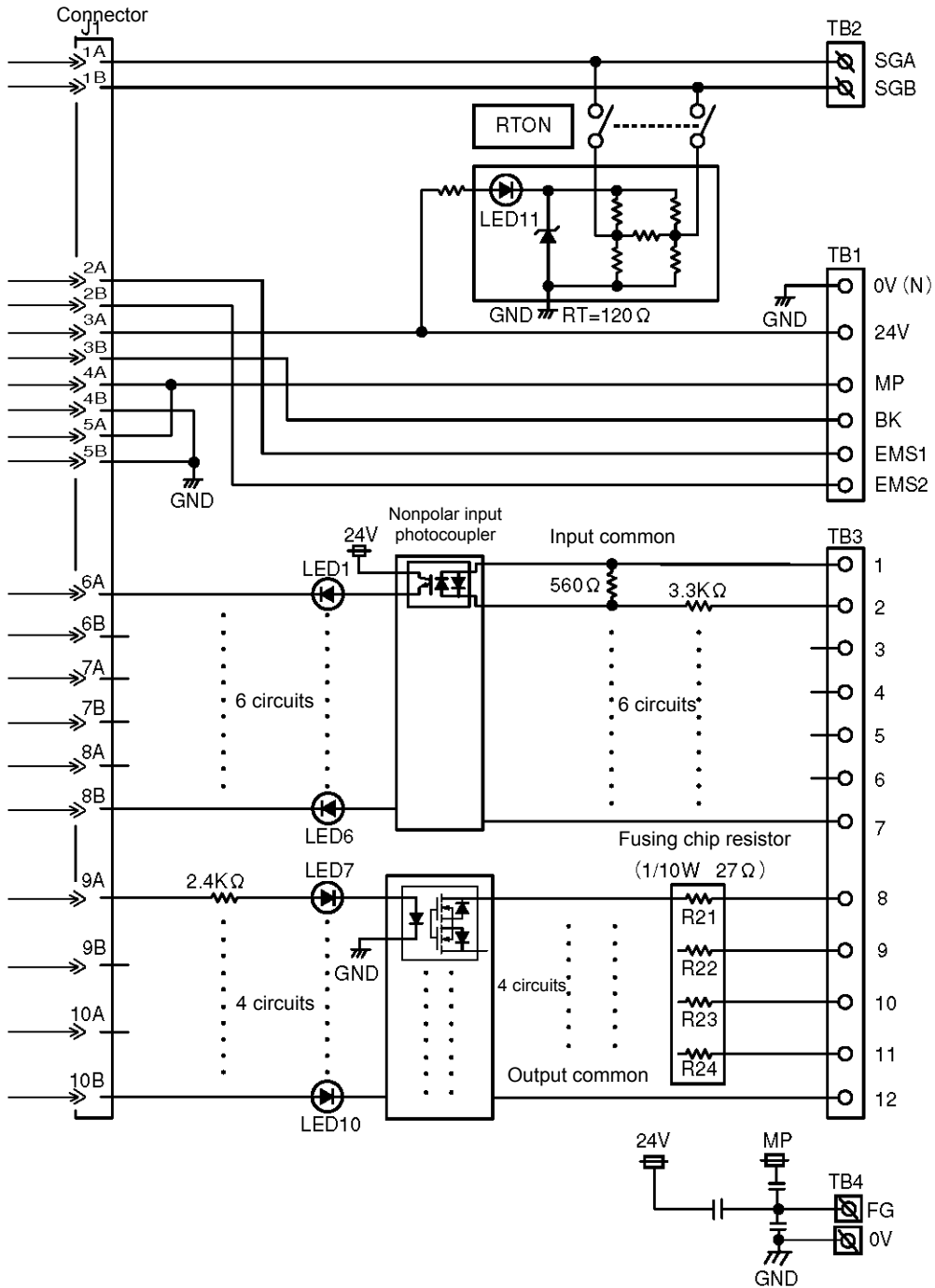

- I/O interface specifications

Input Specifications

Specification item	Description
Number of input points	6 points
Input voltage	$\pm 24\text{VDC} \pm 10\%$
Input current	7 mA/point (bipolar)
Allowable leak current	1 mA/point (approx. 2 mA at normal temperature)
Operating voltage	ON voltage: 16 V min. (4.5 mA) OFF voltage: 5 V max. (1.3 mA)

Output Specifications

Specification item	Description
Number of output points	4 points
Rated load voltage	24VDC
Maximum current	60 mA/point
Residual voltage	2 V or less/60 mA
Shorting/overcurrent protection	Fusing resistor (27 Ω , 0.1 W)

5. Data Entry <Basics>

This actuator doesn't use command words, so there is no need to create a program.

All you need is to enter the target position in the position-data table, and the actuator will move to the specified position.

Position data consists of number (No.), target position (Position), speed (Speed), acceleration/deceleration (ACC), push (Push), positioning band (Pos. band), and acceleration only MAX (ACC MAX). The description in parentheses is as displayed on the teaching pendant.

The target position can be specified in two different modes: by absolute coordinate specification (absolute mode) in which the distance from the home is entered, or by relative coordinate specification (incremental mode) in which the incremental movement from the current position is entered.

Position-data table

No.	Position <small>Note</small>	Speed	Acceleration/ deceleration	Push	Positioning band	Acceleration only MAX
0	0	100	0.3	0	0.1	0
1	30	100	0.3	0	0.1	0
2	10	100	0.3	0	0.1	0
·	·	·	·	·	·	·
·	·	·	·	·	·	·
15	100	100	0.3	0	0.1	0

When data is entered in the position column of the position-data table, the default values will be automatically entered in the remaining columns. Change the default values as necessary.

To change a default value, change the corresponding parameters starting with "Default."

The default values vary depending on the actuator type.

This indicates that the incremental mode is active. (This symbol is displayed only on the teaching pendant. Separate columns for incremental specification are provided in the PC software.)

Note: Enter position data first. Any attempt to enter other data before position data will be rejected. You can enter position data containing two decimal places. However, the controller only recognizes position data as a multiple of its minimum resolution. The minimum resolution of the controller varies depending on the actuator lead. For the above reason, the second decimal place in the entered position data may be rewritten in accordance with the actuator lead.

Example: Entered value Stored value
 50.01 → 50.03

5.1 Description of Position-Data Table

(1) No.

- Indicate the position data number.
To enter an incremental movement, press the minus key in this column.
On the teaching pendant, a “=” will be displayed between the number and position columns.
The minus key need not be pressed in the absolute mode.

(2) Target position (Position)

- Enter the target position to move the actuator to, in [mm].
Absolute mode: Enter the distance to the target actuator position from the home.
Incremental mode: Enter the distance to the target actuator position from the current position. A negative value can also be entered (for movement in the negative direction along the displayed coordinate axis).

No.	Position
0	30
1 =	10
2 =	-10
3	100

Absolute mode 30 mm from the home
Incremental mode +10 mm from the current position
Incremental mode -10 mm from the current position
Absolute mode 100 mm from the home

(3) Speed (Speed)

- Enter the speed at which the actuator will be moved, in [mm/sec].
The default value varies depending on the actuator type.

(4) Acceleration/deceleration (ACC)

- Enter the acceleration/deceleration at which the actuator will be moved, in [G].
Use the rated acceleration specified in the catalog, as a rule.
This product can be used at higher accelerations to shorten the takt time, but only if the actual use conditions are such that the “load is significantly more than the rating.”
To support the above function, the acceleration field in the position table accepts values greater than the rated acceleration.

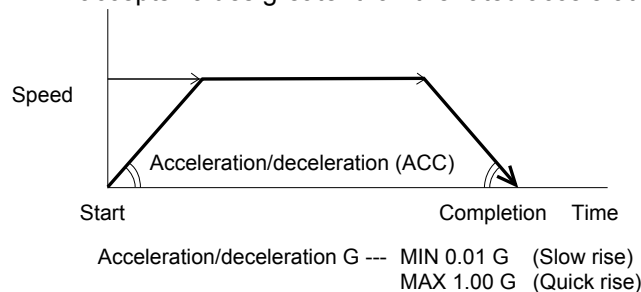

Note: Enter appropriate values for speed and acceleration/deceleration by referring to 1.3, “Specifications” and considering the installation conditions and shape of the load, to make sure the actuator will not receive excessive impact or vibration.
Whether or not the values of speed and acceleration/deceleration should be raised has a lot to do with the transferring mass and how the actuator characteristics will change also varies depending on the model. Consult IAI’s Sales Engineering Section for the maximum values of speed and acceleration/deceleration you can enter.

(5) Push (Push)

- Select the positioning mode or push & hold mode.
The default value is "0."
0: Positioning mode (= Normal operation)
Other than 0: Push & hold mode [%]
- To select the push & hold mode, enter the current-limiting value for the servo motor during push & hold operation. Enter an appropriate value up to 70% in accordance with the actuator type.

Be sure to refer to 5.1.1, "Relationship of Push Force at Standstill and Current-Limiting Value" that specifies the relationship of the push force to be applied to the load at standstill [kgf] on one hand, and the current-limiting value on the other, for each actuator type.

Note: If the push force is too small, a false detection of push & hold condition may occur due to slide resistance, etc., so exercise caution.

(6) Positioning band
(Pos. band)

- The function of the positioning band varies depending on whether the push & hold setting in (5) is "0" or "other than 0."
(A) Push = 0 (Positioning mode)
- In the positioning mode, enter the position-complete detection width (distance to the target position), in [mm].
- The distance to the target position indicates the range prior to the target position, upon entry of the actuator in which range a position complete signal will be output.
The default value is "0.1 [mm]" (Fig. A).
- (B) Push = Other than 0 (Push & hold mode)
- Enter the maximum push amount (distance from the target) in the push & hold mode, in [mm] (Fig. B).
- If the push direction corresponds to the negative direction along the displayed coordinate axis, add a - (minus) sign to the entered value.

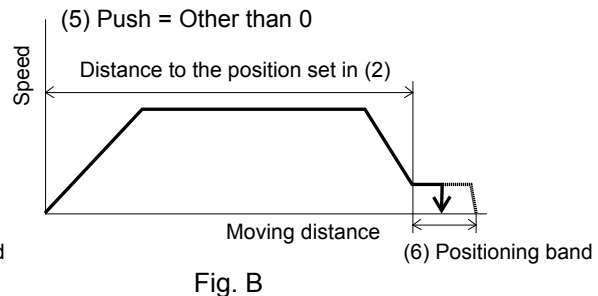
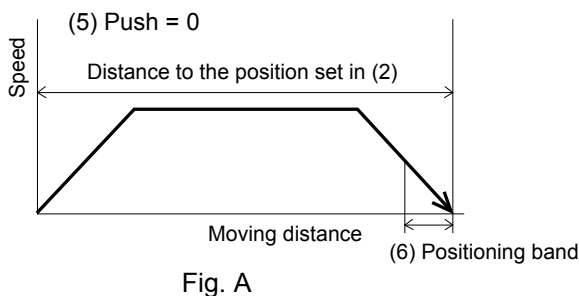

(7) Acceleration only MAX (ACC MAX)

- Select the specified acceleration or maximum acceleration by entering “0” or “1.”
The default value is “0.”

0: Specified acceleration ---

The value entered in (4) becomes the actual acceleration/deceleration.

1: Maximum acceleration ---

The maximum acceleration is applied only during acceleration.

During deceleration, the value input in (4) is used.

(7) Acceleration only MAX = 0

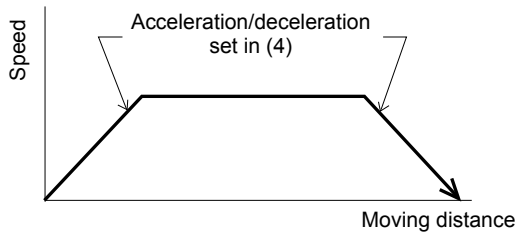

(7) Acceleration only MAX = 1

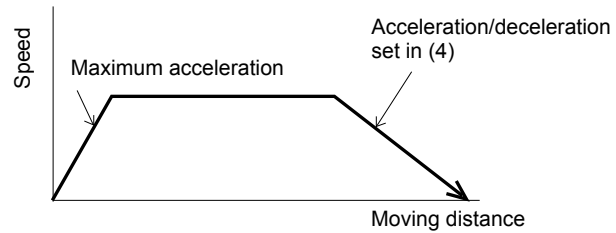

Note: A rough guide for enabling the acceleration only MAX function is when the actual payload capacity is one-third the load rating or less.
Check the payload rating by referring to 1.3, “Specifications.”

RC ROBO CYLINDER

5.1.1 Relationship of Push Force at Standstill and Current-Limiting Value

When performing operation in the push & hold mode, enter the current-limiting value (%) in the push column of the position-data table.

Determine the current-limiting value (%) from the push force to be applied to the load at standstill.

The graphs below illustrate the relationship of push force at standstill and current-limiting value for each actuator type:

- Slider type

(1) SA6 type

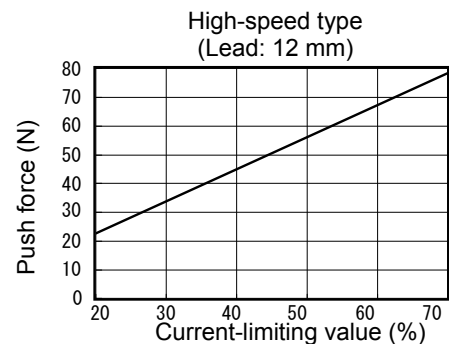
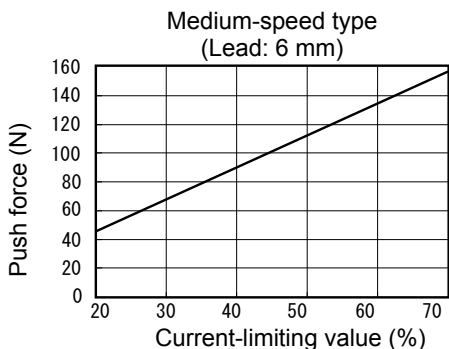
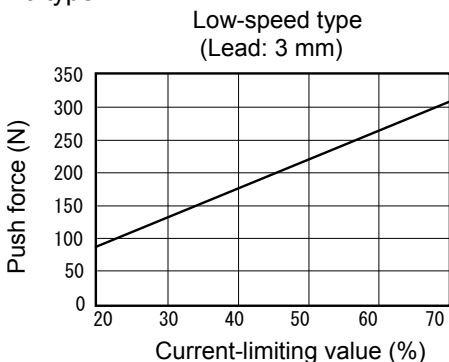

(2) SA7 type

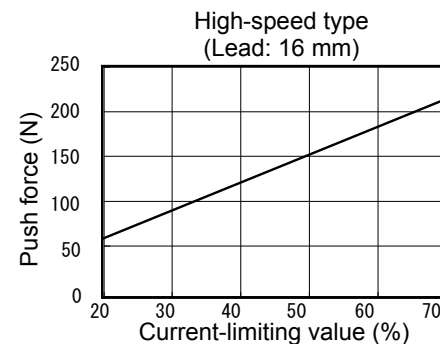
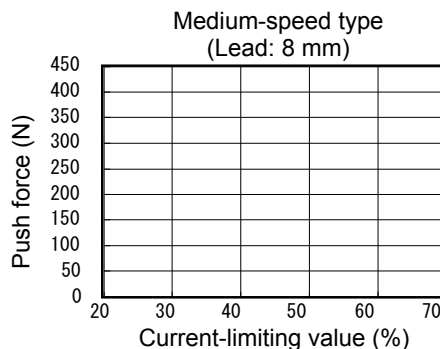
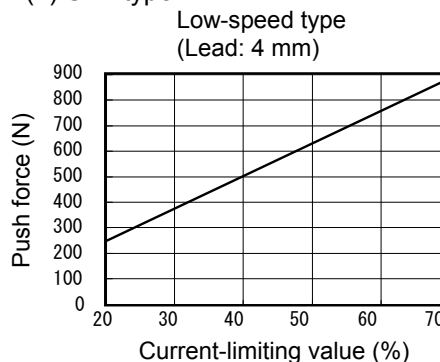

Note: The accuracy of push force at standstill is not guaranteed. The above graphs are provided for reference purposes only. If the push force is too small, malfunction may occur during push & hold operation due to slide resistance, etc., so exercise caution. The maximum current-limiting value is shown in the above graphs. The minimum value is 20%.

- Rod type

(1) RA54 type

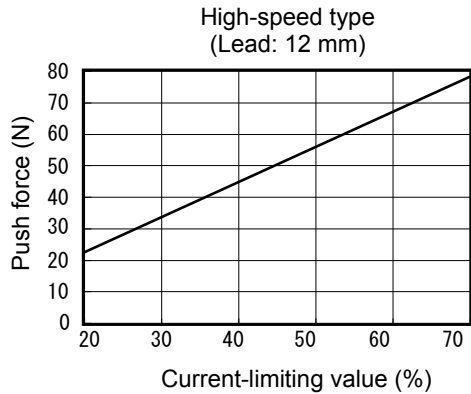
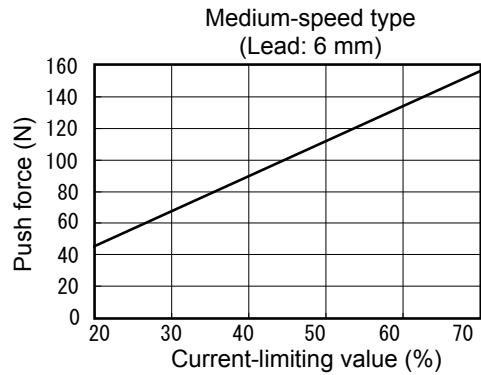
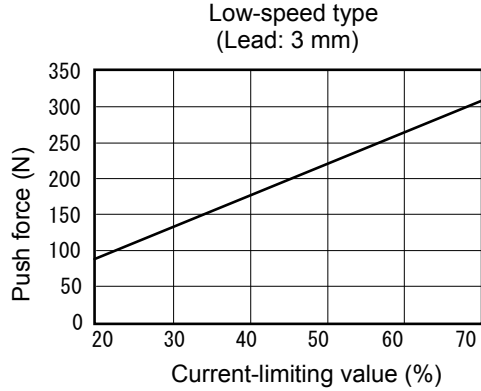

(2) RA64 type

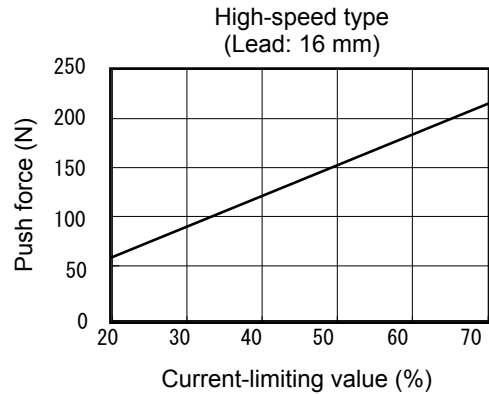
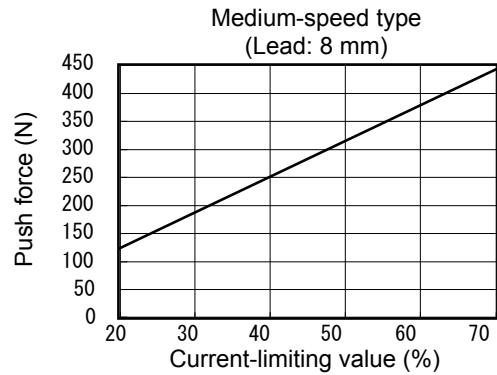
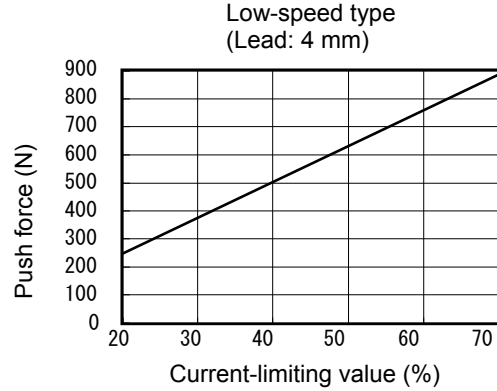

Note: The accuracy of push force at standstill is not guaranteed. The above graphs are provided for reference purposes only. If the push force is too small, malfunction may occur during push & hold operation due to slide resistance, etc., so exercise caution.
The maximum current-limiting value is shown in the above graphs. The minimum value is 20%.

5.2 Explanation of Modes

5.2.1 Positioning Mode Push = 0

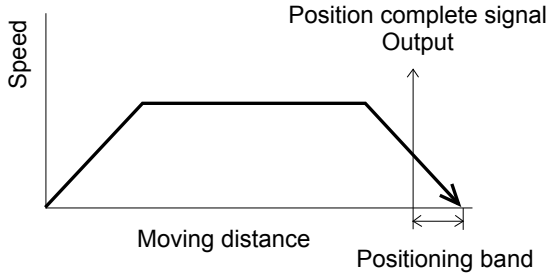

(1) The position complete output will turn ON at a position preceding the target position by the positioning band.

5.2.2 Push & Hold Mode Push = Other than 0

(1) Load was contacted successfully

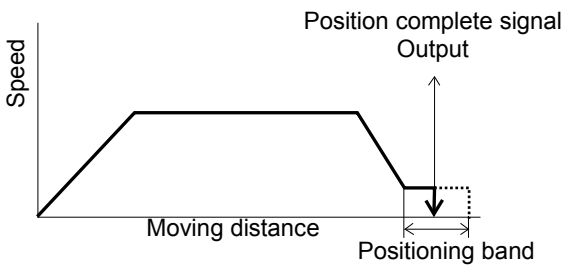

(1) After reaching the target position, the actuator will move at low speed (75 rpms). When the Pos. band set in the data table (see Note) is reached after the actuator contacts the load and the stepper motor current has reached the current-limiting value, the position complete output will turn ON.

Note: Set the parameter "Push & hold stop judgment period." The default value of "255 [msec]" is already entered.

The actuator is holding the load in position while pushing it.

Warning

The actuator continues to push the load at the push force at standstill determined by the current-limiting value. Since the actuator is not inactive, exercise due caution when handling the machine in this condition.

The push speed is set as follows in accordance with the speed set in the position-data table:

	Set speed	
	20 mm/sec or more	Less than 20 mm/sec
Push speed	20 mm/sec	Set speed

(2) Load was not contacted (missed)

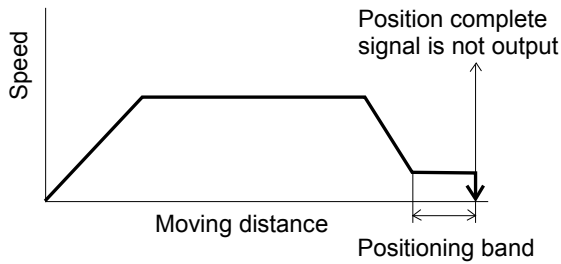

(1) After reaching the target position, the actuator will move at low speed. Even after contacting the load, the actuator will move to the end of the positioning band if the stepper motor current is yet to reach the current-limiting value. The position complete output will not turn ON even when the end of the positioning band is reached. (Provide a timeout check process after a sufficient period with a PLC.)

(3) Load moves during push & hold operation
(a) Load moves in the pushed direction

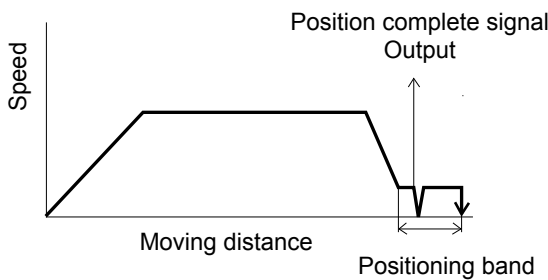

If the load moves in the pushed direction after the position complete output has turned ON, the actuator will push the load within the positioning band. If the current drops below the limiting value, the position complete signal will turn OFF. The signal will turn ON when the current rises to or above the limiting value.

(b) Load moves in the opposite direction
(Actuator is pushed back by the reactive force of the load)

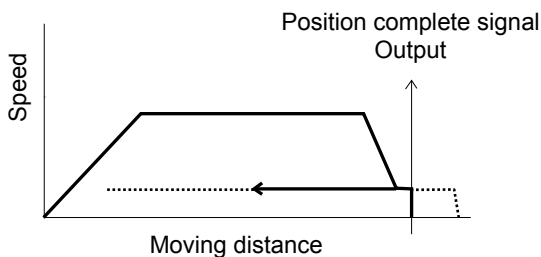

If the actuator is pushed back after the position complete output has turned ON because the actuator thrust is smaller than the reactive force of the load, the actuator will be pushed back all the way until its thrust balances out with the reactive force of the load. The position complete output will remain ON.

(4) Positioning band was entered with a wrong sign

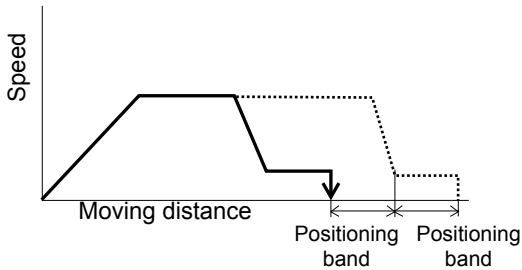

If the positioning band is entered with a wrong sign, the position will deviate by twice the positioning band, as shown to the left, so exercise due caution.

5.2.3 Speed Change during Movement

Speed control involving multiple speed levels is possible in a single operation. The actuator speed can be decreased or increased at a certain point during movement. However, the position at which to implement each speed change must be set.

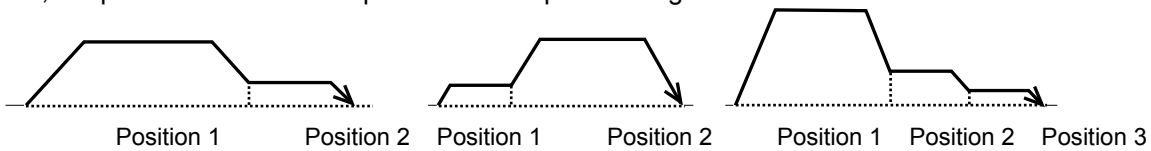

5.2.4 Operation at Different Acceleration and Deceleration Settings

The actuator will accelerate and decelerate at different speeds if "1" is entered under "Acceleration only MAX" in the position data.

The acceleration will conform to the maximum acceleration set according to the load, while the deceleration will conform to the value entered in "Acceleration/deceleration" of the position data.

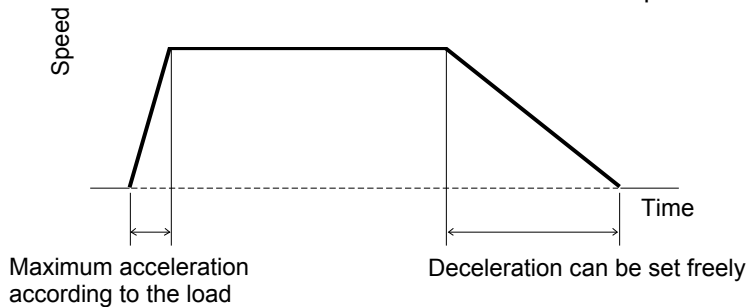

Note: The maximum acceleration varies from actuator to actuator, but the limit is generally three times the rated acceleration. Accordingly, enable this function only when the transferring mass is one-third the rating or less and you want to decelerate the actuator over a gradual acceleration curve when stopping. If this function is enabled when the transferring mass is equal to the rating, an overload error may occur. Exercise due caution because even if an overload error does not occur, the actuator will receive an excessive impact load and its life will be negatively affected. Check the payload rating by referring to 1.3, "Specifications."

5.2.5 Pause

The actuator can be paused during movement using an external input signal (*pause). The pause signal uses the contact B logic (always ON) to ensure safety. Turning OFF the *pause input will cause the actuator to decelerate to a stop, while turning it ON will allow the actuator to complete the remaining operation.

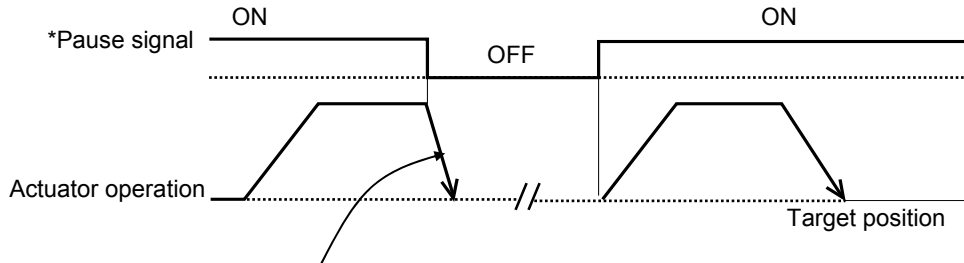

(Note) During deceleration, the acceleration/deceleration set in the position table under the currently executed position number is used.

5.2.6 Zone Signal Output

A signal will be output when the actuator enters the specified zone. The zone signal will turn ON when the actuator enters the zone predefined by the applicable parameters. (The zone can be set arbitrarily.)

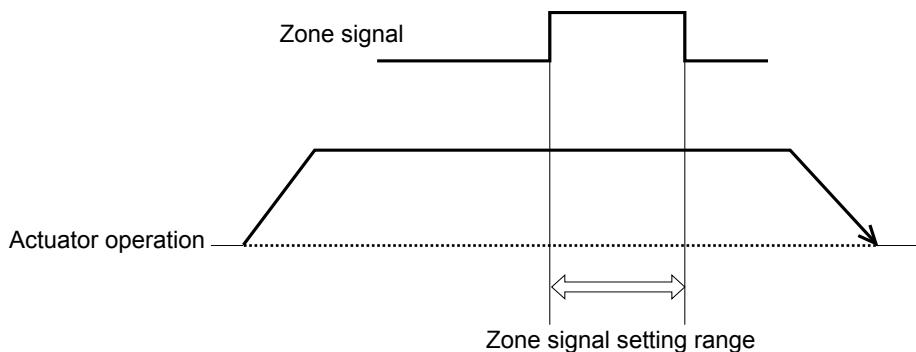

5.2.7 Home Return

After the power is turned on, home return must be executed to establish the home. Upon occurrence of a cold-start level error, the power must be reconnected to restore the system. In this case, home return is also required after the reconnection of power.

Which home return method is used will vary depending on the PIO pattern selected.

- Home return using a dedicated input [PIO pattern = 0 (8 points)]
Home return can be executed using the home return (HOME) input. Turning ON this input will execute home return regardless of whether or not it has already been executed once.
When the home return is complete, the home return completion (HEND) output will turn ON.
 - Home return not using a dedicated input [PIO pattern = 2 (16 points)]
Even if home return has not been executed yet, issuing a start command by specifying a position will cause the actuator to return to the home before moving to the specified position.
- ★ For details, refer to 7.2, "How to Execute Home Return."

6. Operation in the “3 Points (Air Cylinder)” Mode <Practical Operation>

6.1 Overview of the “3 Points” Mode

This mode provides a control method adjusted to that of an air cylinder by assuming that the ERC is used as an air cylinder.

The key differences between the ERC and an air cylinder are summarized below. Perform proper control by referring to this table.

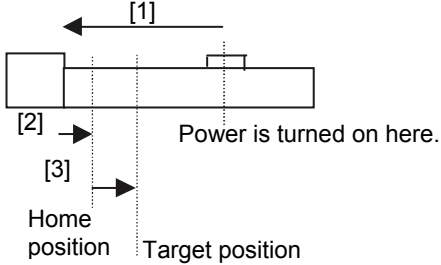
Item	Air cylinder	ERC
Drive method	Air pressure supplied via electromagnetic valve control	Ball screw/timing belt driven by a motor
Target position setting	Mechanical stopper (including shock absorber)	Desired coordinates are entered in the [Target position] field of the position table. The coordinates can be typed in from the number keys on the PC keyboard or on the teaching pendant, or set directly by moving the actuator to the target position.
Target position detection	An external detection sensor, such as a reed switch, is installed.	Determined based on the internal coordinates provided by the position information from the position detector (encoder). Accordingly, external detection sensor is not required.
Speed setting	Adjusted by a speed controller.	A desired feed speed is entered in the [Speed] field of the position table (unit: mm/sec). Note that the rated speed is automatically set as the initial value.
Acceleration/ deceleration setting	Determined in accordance with the load, supplied air volume, as well as the performance of the speed controller and electromagnetic valve.	A desired acceleration/deceleration is entered in the [Acceleration/deceleration] field of the position table (unit: 0.01 G). (Reference) 1 G = Gravitational acceleration Note that the rated acceleration/deceleration is automatically set as the initial value. Since the acceleration/deceleration can be set in fine steps, a gradual acceleration/deceleration curve can be programmed.
Position check upon power ON	Determined by an external detection sensor, such as a reed switch.	Immediately after the power is turned on, the controller cannot identify the current position because the mechanical coordinates have been lost. Therefore, when the first movement command is issued after the power has been input, the controller will automatically perform home return before moving the actuator to the target position.  <ul style="list-style-type: none"> [1] The actuator moves at the home return speed toward the mechanical end on the motor side. [2] The actuator hits the mechanical end and turns back, and then stops temporarily at the home position. [3] The actuator moves to the target position at the speed specified in the [Speed] field of the position table. <p>(Note) Pay attention not to allow any obstacle in the travel path of the actuator during home return.</p>

The relationships of movement command inputs/position complete outputs and corresponding position numbers are shown below.

For easier identification, each input/output signal has a name similar to the naming convention used with air cylinders.

However, note that the target position is determined by the value set in the [Target position] field under each position number. Therefore, changing the magnitude correlation of the settings in Nos. 0 to 2 will change the meanings of the corresponding input/output signals.

Accordingly, the settings in the respective position numbers should match the semantic meanings of the corresponding signal names used in this operation manual, unless doing so will pose a problem.

Input signal	Output signal	Target position
Rear end move (ST0)	Rear end complete (PE0)	Setting in the [Target position] field under position No. 0 Example: 5 mm
Front end move (ST1)	Front end complete (PE1)	Setting in the [Target position] field under position No. 1 Example: 390 mm
Intermediate point move (ST2)	Intermediate point complete (PE2)	Setting in the [Target position] field under position No. 2 Example: 200 mm

- Positioning relationships on the Robo Cylinder
This example assumes the use of a slider type actuator with a 400 mm stroke.

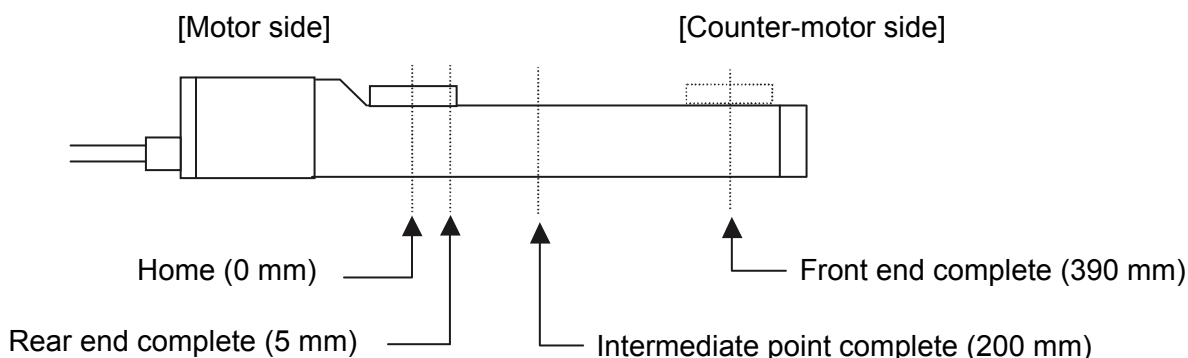

- Position table (Field(s) within thick line must be entered.)

No.	Position	Speed	Acceleration/deceleration	Push	Positioning band	Acceleration only MAX
0	5	500	0.3	0	0.1	0
1	390	500	0.3	0	0.1	0
2	200	500	0.3	0	0.1	0

6.2 How to Start

- (1) Confirm that the connector end (CN1) of the relay cable is firmly plugged into the connector on the actuator cable.
- (2) Connect the PLC and the parallel I/O.
- (3) If the actuator has brake, set the brake release switch to OFF.
- (4) Supply 24 VDC to the control power supply.
Cut off the motor-drive power supply (actuate an emergency stop) beforehand.
- (5) Confirm that the slider or rod is not contacting the mechanical end. If the slider or rod is contacting the mechanical end, or when the slider or rod is positioned between the mechanical end and home, move the slider/rod away from the home position toward the direction opposite to the mechanical end.
If the actuator is equipped with a brake, move the slider/rod after releasing the brake by turning on the brake release switch. At this time, pay attention to prevent the work from falling by its dead weight and protect your hand, robot, and the work from injuries/damages.
If the screw lead is short and you cannot adjust it manually, set the excited-phase signal detection direction in parameter No. 28 to opposite the mechanical end.

 **Warning:** Turning on the servo while the slider or rod is still contacting the mechanical end may disable accurate detection of the excited phase, resulting in malfunction or excitation detection error.

- (6) Connect a PC or teaching pendant and set the minimum parameters required.
 - If the pause input is not used, set parameter No. 15 “Pause input disable selection” to “1.”
 - Set parameter No. 25 “PIO pattern selection” to “1” (this setting is required).
 - If you want to use the movement command input based on the “edge mode,” set parameter No. 27 to “1.”Refer to 8, “Parameters” for details.
- (7) Cancel the emergency stop so that the motor drive power will be supplied.
 - ★ The controller servo will be turned on and a green LED lamp will illuminate on the motor cover.
- (8) If the pause signal (*STP) is enabled, turn the signal ON from the PLC.
 - ★ A red LED lamp indicates an alarm. Remove the cause of the alarm.For details, refer to 9, “Troubleshooting.”
- (9) Perform home return.
 - Overview of operation on the teaching pendant
 - On the RCA-T, select the Edit/Teach screen, bring the cursor to ***Home** in the sub-display area, and then press the ENTER key.
 - On the RCA-E, select the Teach/Play screen, scroll the pages until ***Home Return** is shown, and then press the ENTER key.
 - On the RCB-J, the screen showing **RUN Key → Home Return** is displayed automatically. Press the RUN key.
 - Overview of operation in the PC software
 - In the main window, select the applicable position data, and then click **Home**.

For details of each operation, refer to the operation manual for the applicable teaching pendant or PC software.

If the actuator does not perform home return, confirm that the *pause signal is ON, the motor-drive power supply is receiving power, and no error messages are displayed, among others.

- (10) Set the target position, speed, acceleration/deceleration, positioning band and other data in the position table. For details on how to set data in the position table, refer to the operation manual for the teaching pendant or PC software, whichever is applicable.
Now, you can operate the actuator automatically via control from the PLC.

Note: Move the actuator to the target position after confirming that the *ALM output is ON and the motor drive power is supplied.

Timing chart at start

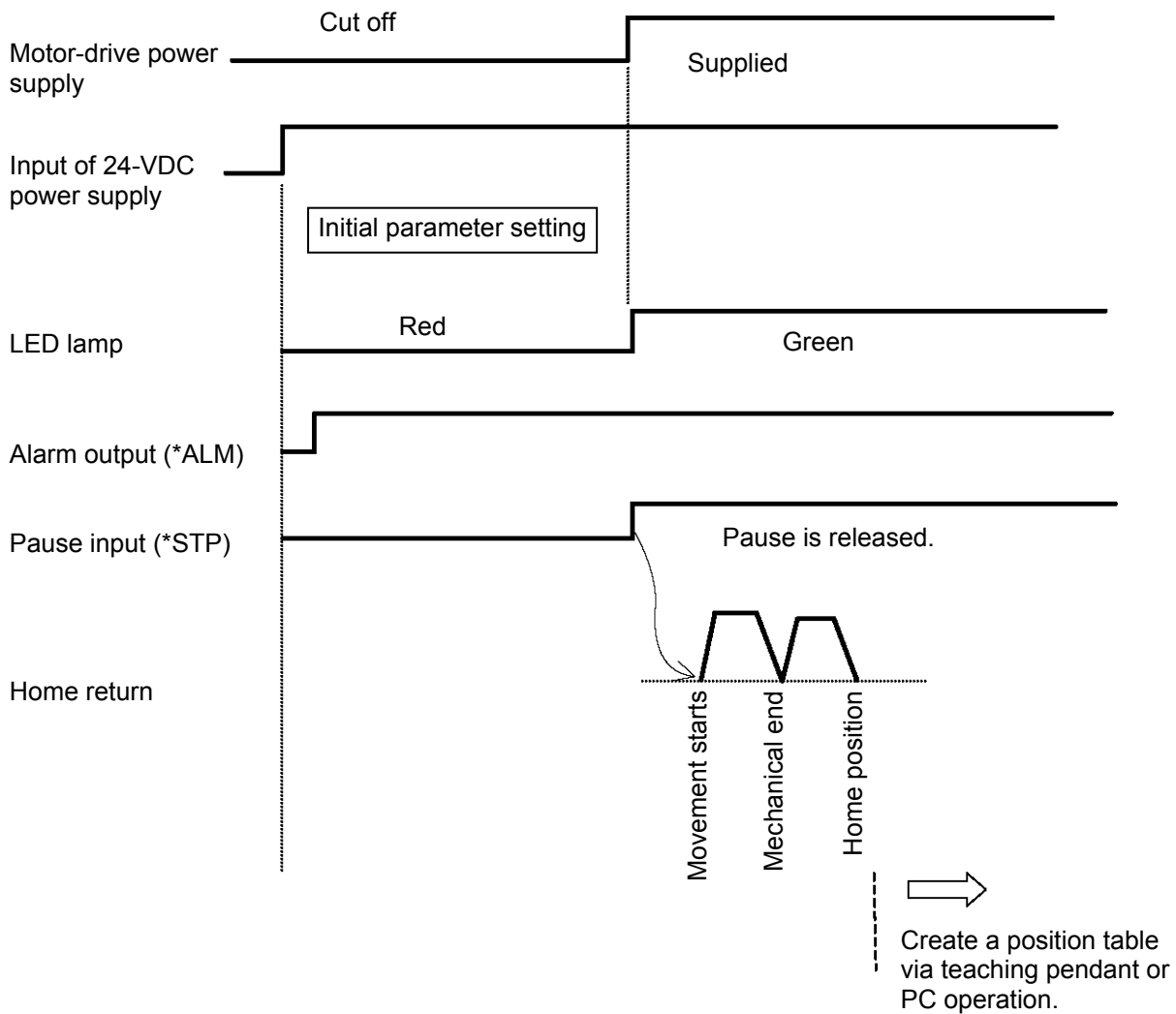

6.3 Moving Operation

First, make the controller ready to accept movement commands by referring to 6.2, "How to Start."

Example of use in operation) Turn on the power, and then cause the actuator to move back and forth between the rear end (5 mm) and front end (390 mm) via an intermediate point (200 mm).

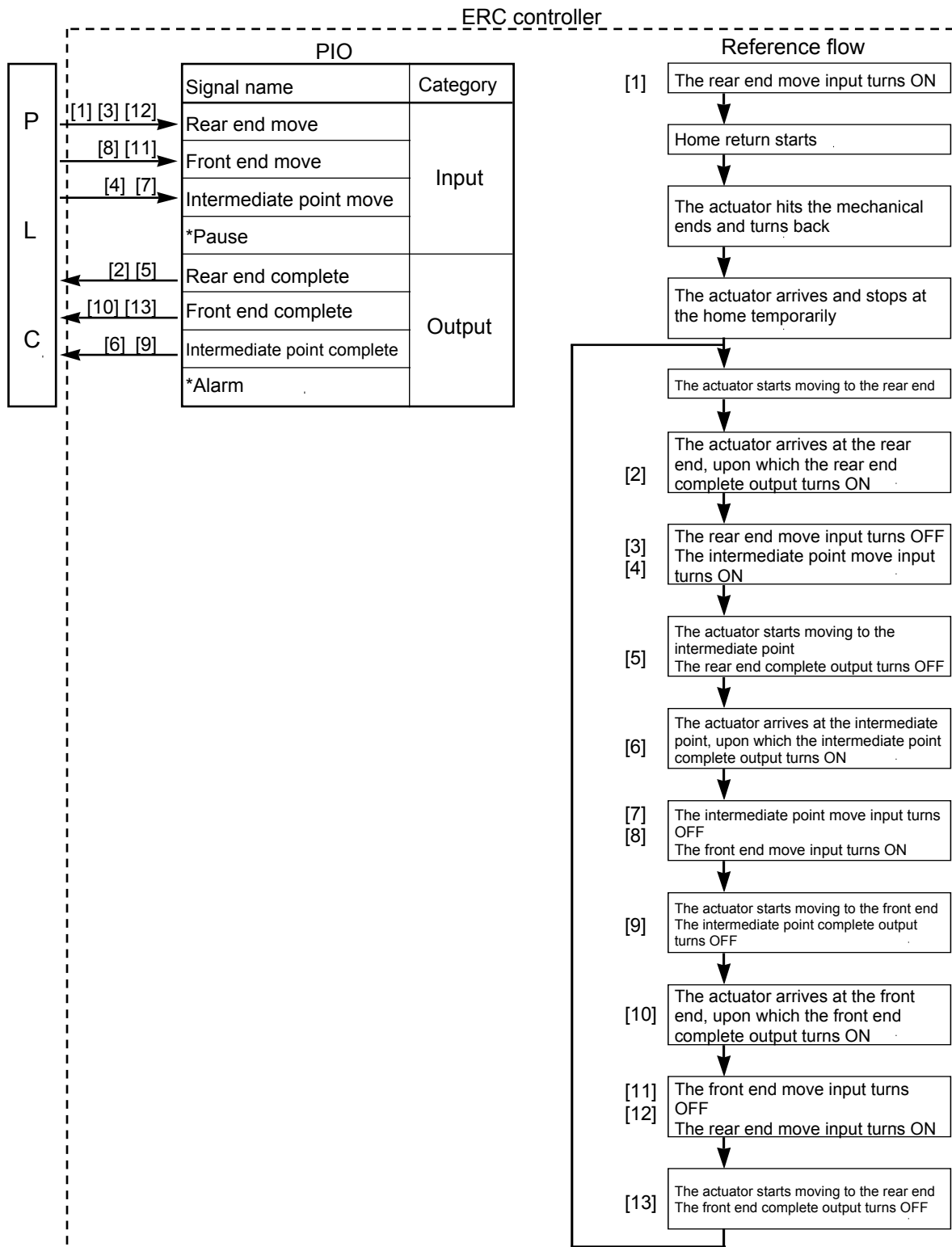

[Operation timings]

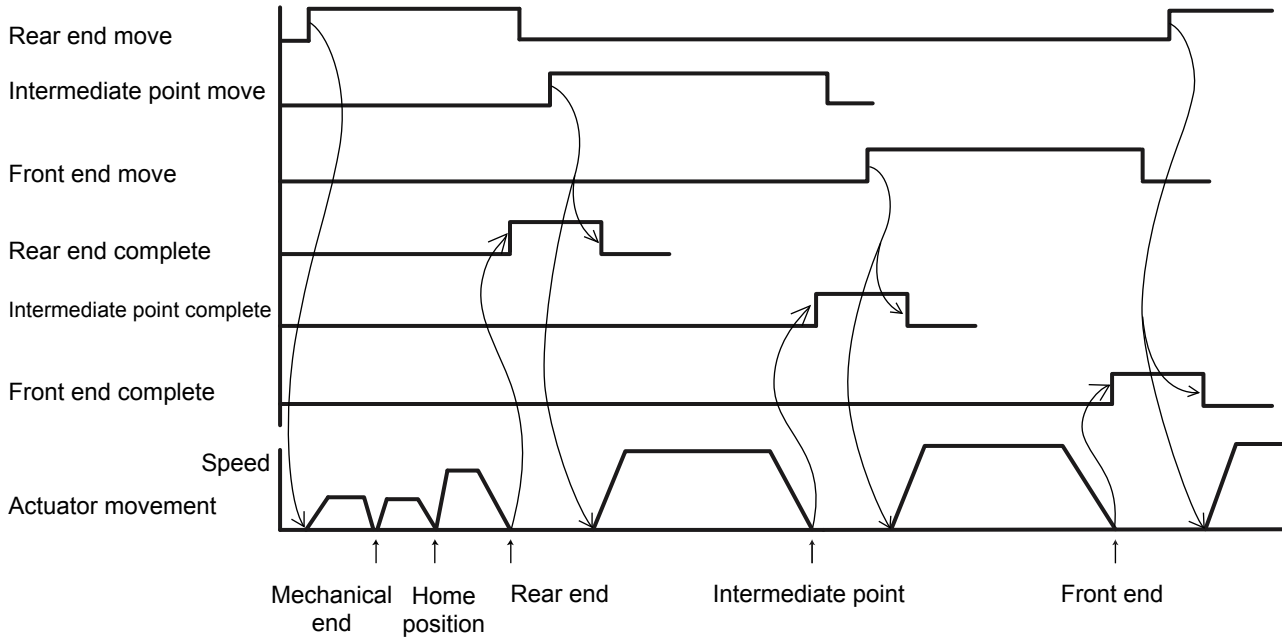

Note: Movement commands are executed based on the rise edge, so input each signal continuously for 6 msec or more.
 If two or more movement commands are input simultaneously, they will be executed according to the following priorities:
 Priorities: [1] Rear end, [2] Front end, [3] Intermediate point
 The sequence circuit on the PLC side must ensure only one command is input at a time.

- The movement command input operates in two modes.
You can select the operation condition of the movement command input (ST0 to ST2) in parameter No. 27.
The factory setting is "0: [Level mode]."

Description of the movement command input	Setting
Level mode: The actuator starts moving when the input signal turns ON. When the signal turns OFF during the movement, the actuator will decelerate to a stop and complete its operation.	0
Edge mode: The actuator starts moving when the rise edge of the input signal is detected. The actuator will not stop even when the signal turns OFF during the movement, until the target position is reached.	1

[Level mode]

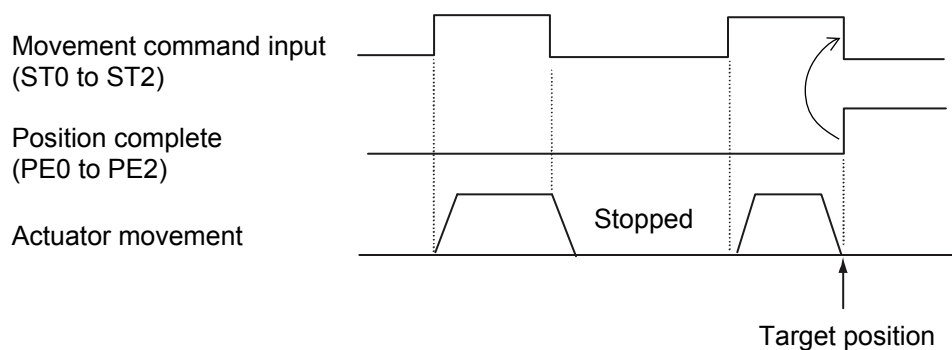

(Note) Turn OFF the movement command input after confirming that the target position has been reached.

[Edge mode]

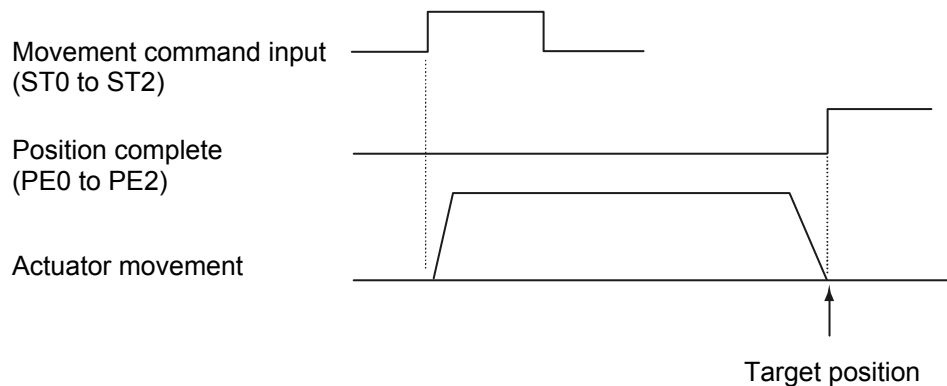

- Handling of the pause (*STP) signal

This signal is a Contact B signal, meaning that it must remain ON while the actuator is moving.

If the pause signal turns OFF while the actuator is moving, the actuator will decelerate to a stop.

The actuator will start moving when the signal turns ON again.

Use this signal as an interlock that actuates when an operator entry prohibition sensor or contact prevention sensor is activated.

If the pause signal is not to be used, set parameter No. 15 (Pause input disable selection) to "1," and the actuator will move even when this signal is OFF.

(Note) When the "edge mode" is selected as the movement command type, you may want to change the target position while the actuator is stopped with this signal turned OFF. In this case, input a movement command specifying the new target position, and then turn ON this signal.

(Example) If the pause signal is turned OFF while the actuator is moving following the input of an intermediate point move command, the accelerator will decelerate to a stop.

- Turn OFF the intermediate point move signal, and then turn ON the front end move signal.
- When the pause signal is turned ON again, the controller will recognize the front end as the new target position.

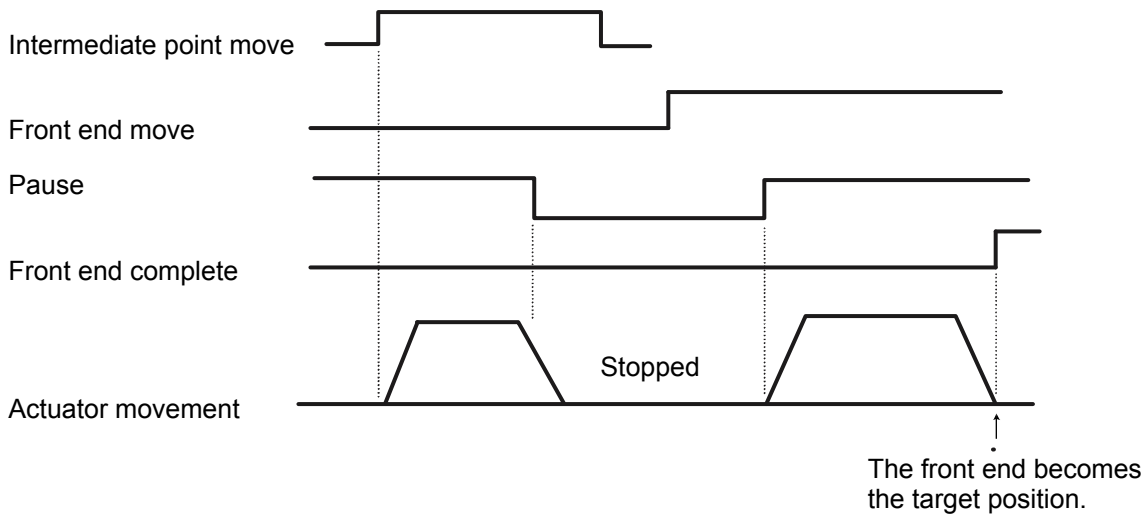

7. Operation in the “8 Points” and “16 Points” Modes <Practical Operation>

7.1 How to Start

- (1) Confirm that the connector end (CN1) of the relay cable is firmly plugged into the connector on the actuator cable.
- (2) Connect the PLC and the parallel I/O.
- (3) If the actuator has a brake, set the brake release switch to OFF.
- (4) Supply 24 VDC to the control power supply.
Cut off the motor-drive power supply (actuate an emergency stop) beforehand.
- (5) Confirm that the slider or rod is not contacting the mechanical end. If the slider or rod is contacting the mechanical end, or when the slider or rod is positioned between the mechanical end and home, move the slider/rod away from the home position toward the direction opposite to the mechanical end.
If the actuator is equipped with a brake, move the slider/rod after releasing the brake by turning on the brake release switch. At this time, pay attention to prevent the work from falling by its dead weight and protect your hand, robot, and the work from injuries/damages.
If the screw lead is short and you cannot adjust it manually, set the excited-phase signal detection direction in parameter No. 28 to opposite the mechanical end.

 **Warning:** Turning on the servo while the slider or rod is still contacting the mechanical end may disable accurate detection of the excited phase, resulting in malfunction or excitation detection error.

- (6) Connect a PC or teaching pendant and set the minimum parameters required.
 - If the pause input is not used, set parameter No. 15 “Pause input disable selection” to “1.”
 - To select “16 points,” set parameter No. 25 “PIO pattern selection” to “2” (this setting is required).
For details, refer to 8, “Parameters.”
- (7) Cancel the emergency stop so that the motor drive power will be supplied.
 - ★ The controller servo will be turned on and a green LED lamp will illuminate on the motor cover.
- (8) If the pause signal (*STP) is enabled, turn the signal ON from the PLC.
 - ★ The position complete output (PEND) will turn ON.
 - ★ A red LED lamp indicates an alarm. Remove the cause of the alarm.
For details, refer to 9, “Troubleshooting.”
- (9) Perform home return.
 - Overview of operation on the teaching pendant
 - On the RCA-T, select the Edit/Teach screen, bring the cursor to ***Home** in the sub-display area, and then press the ENTER key.
 - On the RCA-E, select the Teach/Play screen, scroll the pages until ***Home Return** is shown, and then press the ENTER key.
 - On the RCB-J, the screen showing **RUN Key → Home Return** is displayed automatically. Press the RUN key.
 - Overview of operation in the PC software
In the main window, select the applicable position data, and then click **Home**.

For details of each operation, refer to the operation manual for the applicable teaching pendant or PC software.

If the actuator does not perform home return, confirm that the *pause signal is ON, the motor-drive power supply is receiving power, and no error messages are displayed, among others.

- (10) Set the target position, speed, acceleration/deceleration, positioning band and other data in the position table. For details on how to set data in the position table, refer to the operation manual for the teaching pendant or PC software, whichever is applicable.

Now, you can operate the actuator automatically via control from the PLC.

Note: Issue a command from the PLC after confirming that the position complete output (PEND) is ON.

Timing chart at start

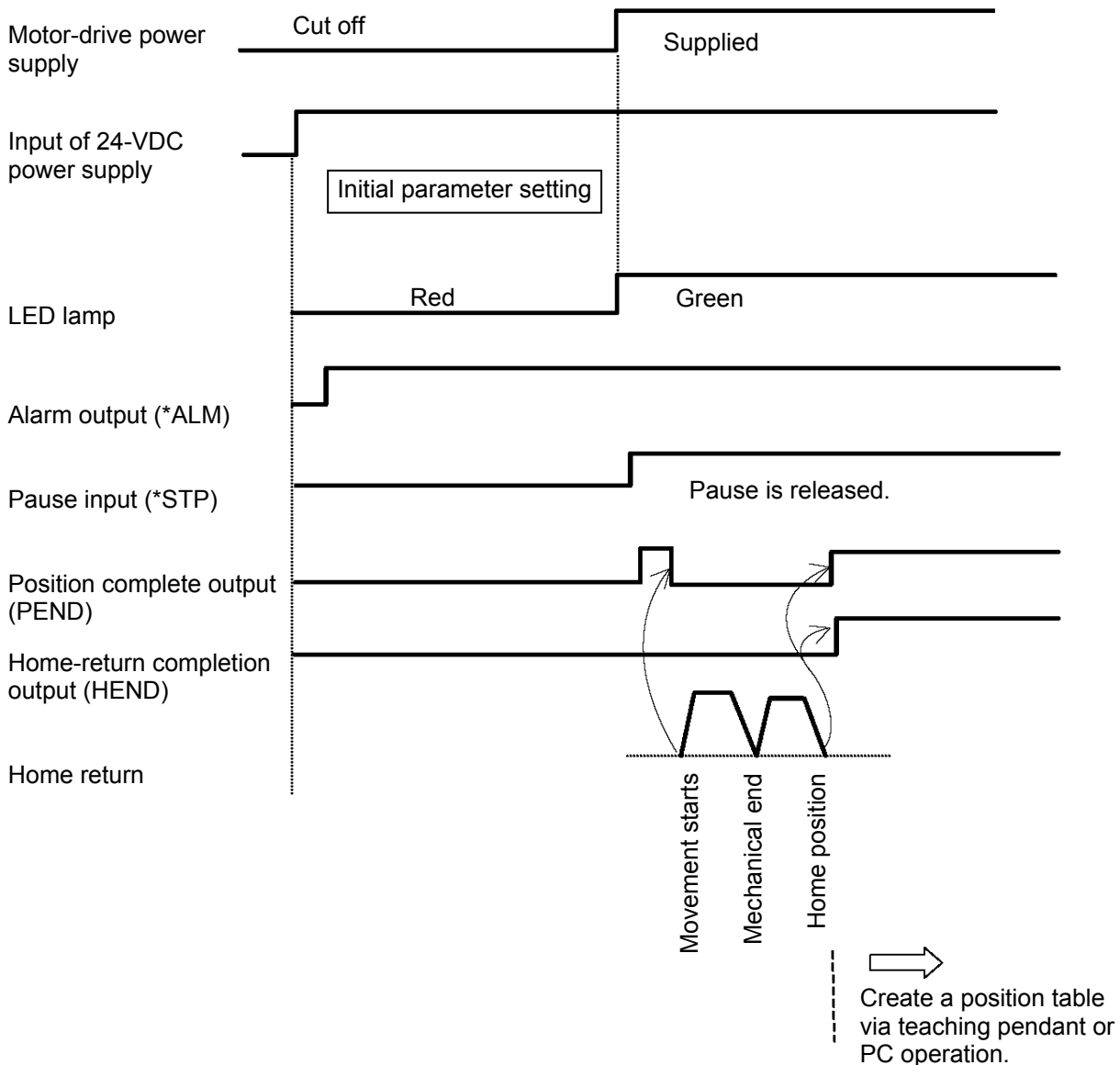

7.2 How to Execute Home Return

First, force the position complete signal to turn ON by referring to 7.1, "How to Start."

7.2.1 8 Points

Enter the home return signal (HOME).

When home return is completed, the home return completion signal (HEND) and position complete signal (PEND) will be turned ON.

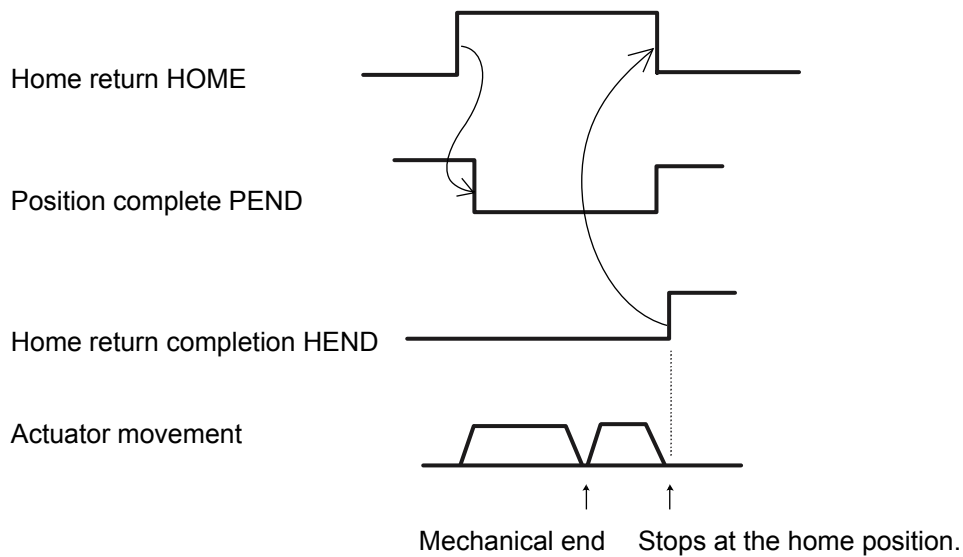

Note: When the home return signal turns ON, the position complete output will turn OFF.
Always turn OFF the home return signal after confirming that the home return completion output has turned ON.

7.2.2 16 Points

Input a start signal after selecting and inputting a desired command position number in which a target position is registered.

Home return is executed first, and then the actuator will move to the target position.

The home return completion signal (HEND) will be turned ON at the home position, and upon reaching the target position the position complete signal (PEND) will be turned ON.

To stop the actuator at the home position, set the target position to "0."

(Example) When "100 mm" is set as the target position in position No. 3, and the home position is not yet established

[Operation under the standard specification]

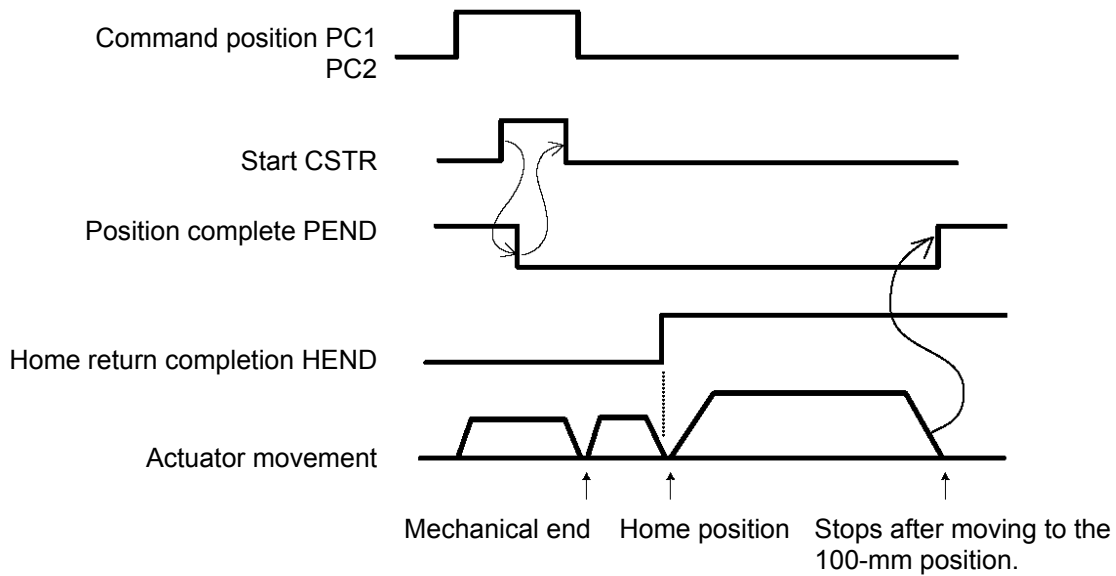

7.3 Home Return and Movement after Start (16 Points)

First, set the necessary data in the position table by referring to 7.1, "How to Start."
 If home return has not yet been executed immediately after the system start, issuing a start command by specifying a position will cause the actuator to return to the home before moving to the specified position.
 Example of use in operation) Home return is performed after the power ON, followed by positioning to the position 150 mm from the home at a speed of 200 mm/sec.

Position-data table (Field(s) within thick line must be entered.)

No.	Position	Speed	Acceleration/ deceleration	Push	Positioning band	Acceleration only MAX
0	0	100	0.3	0	0.1	0
1	150	200	0.3	0	0.1	0
⋮						

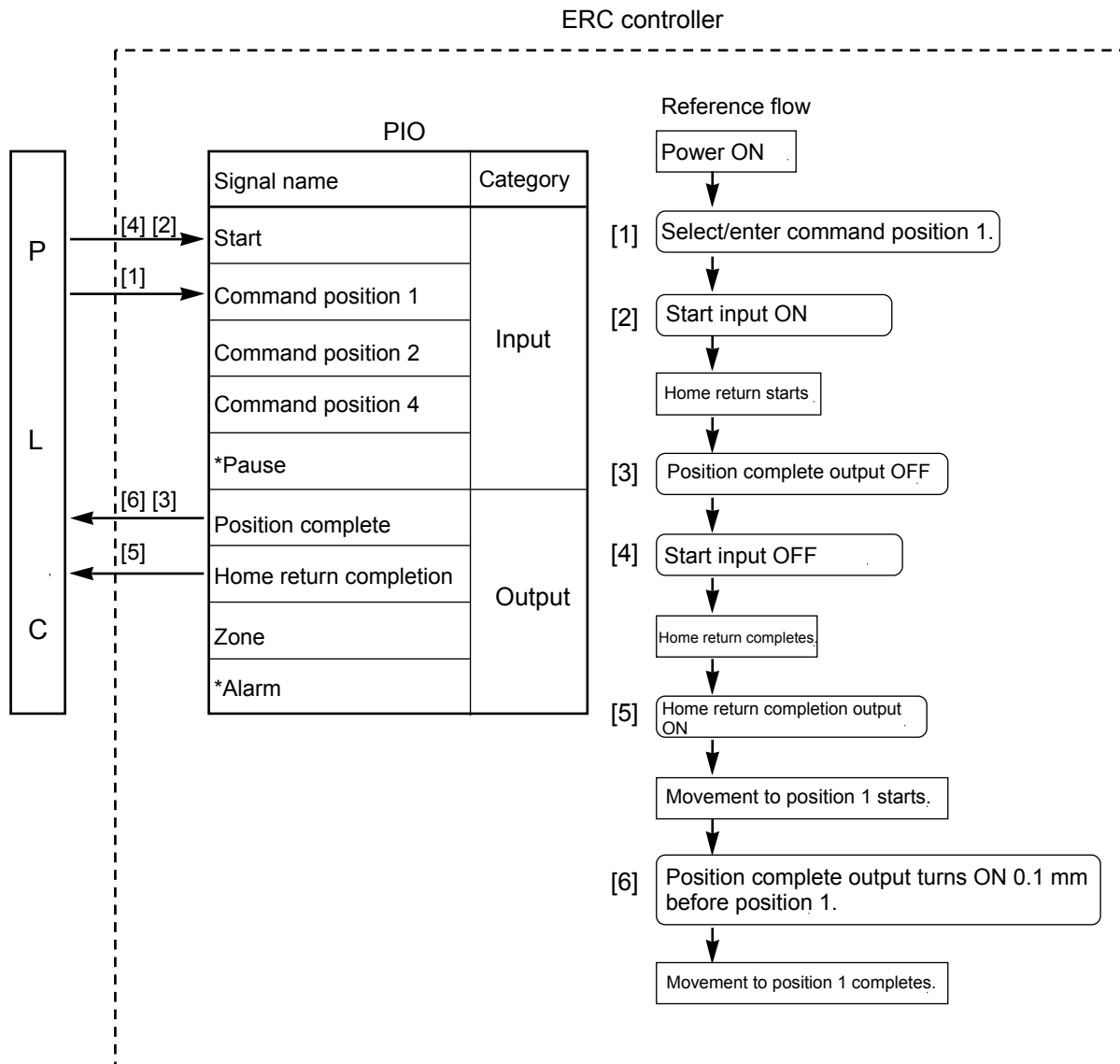

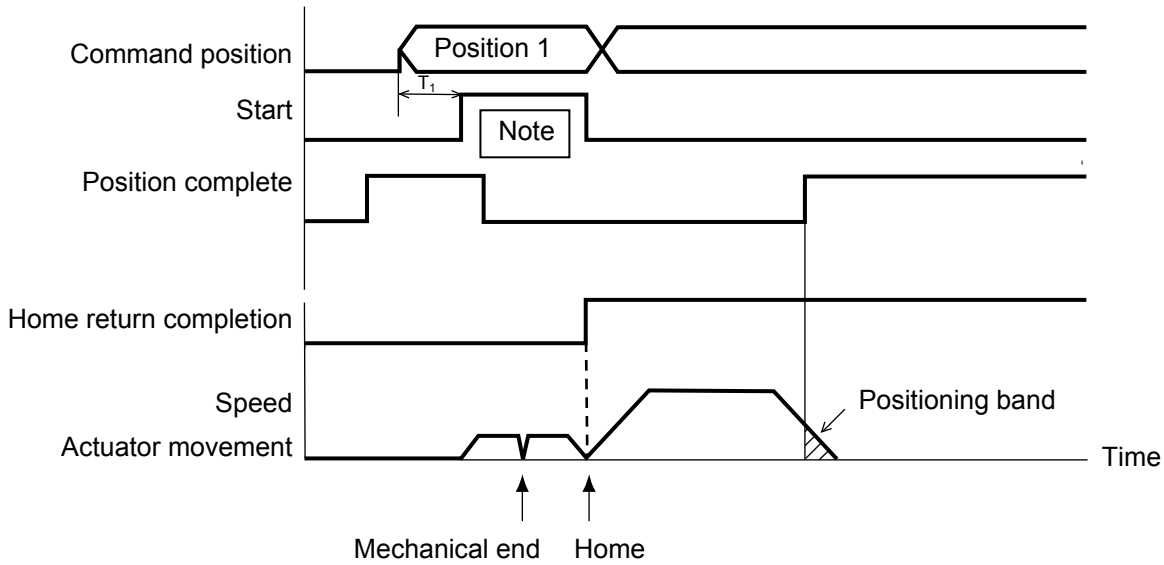

The position complete output will turn ON when the controller becomes ready following the power ON. To check if the controller is ready, always check if the position complete output is ON. The actuator will not operate unless the pause input is turned ON.
 T1: 6 msec or more; time after selecting/entering a command position until the start input turns ON (The scan time of the host controller must be considered.)

Note: When the start signal turns ON, the position complete output will turn OFF. The start signal must be turned OFF with the confirmation that the position complete output has turned OFF while the start signal remains ON. If the start input remains ON as shown below, the position complete output will not turn ON even when the actuator movement is completed.

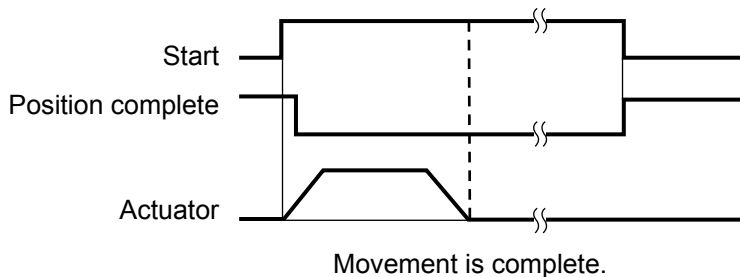

7.4 Positioning Mode (Back and Forth Movement between Two Points)

Example of use in operation) The actuator moves back and forth between two positions. The position 250 mm from the home is set as position 1, and the position 100 mm from the home is set as position 2. The travel speed to position 1 is set as 200 mm/sec, and to position 2 is set as 100 mm/sec.

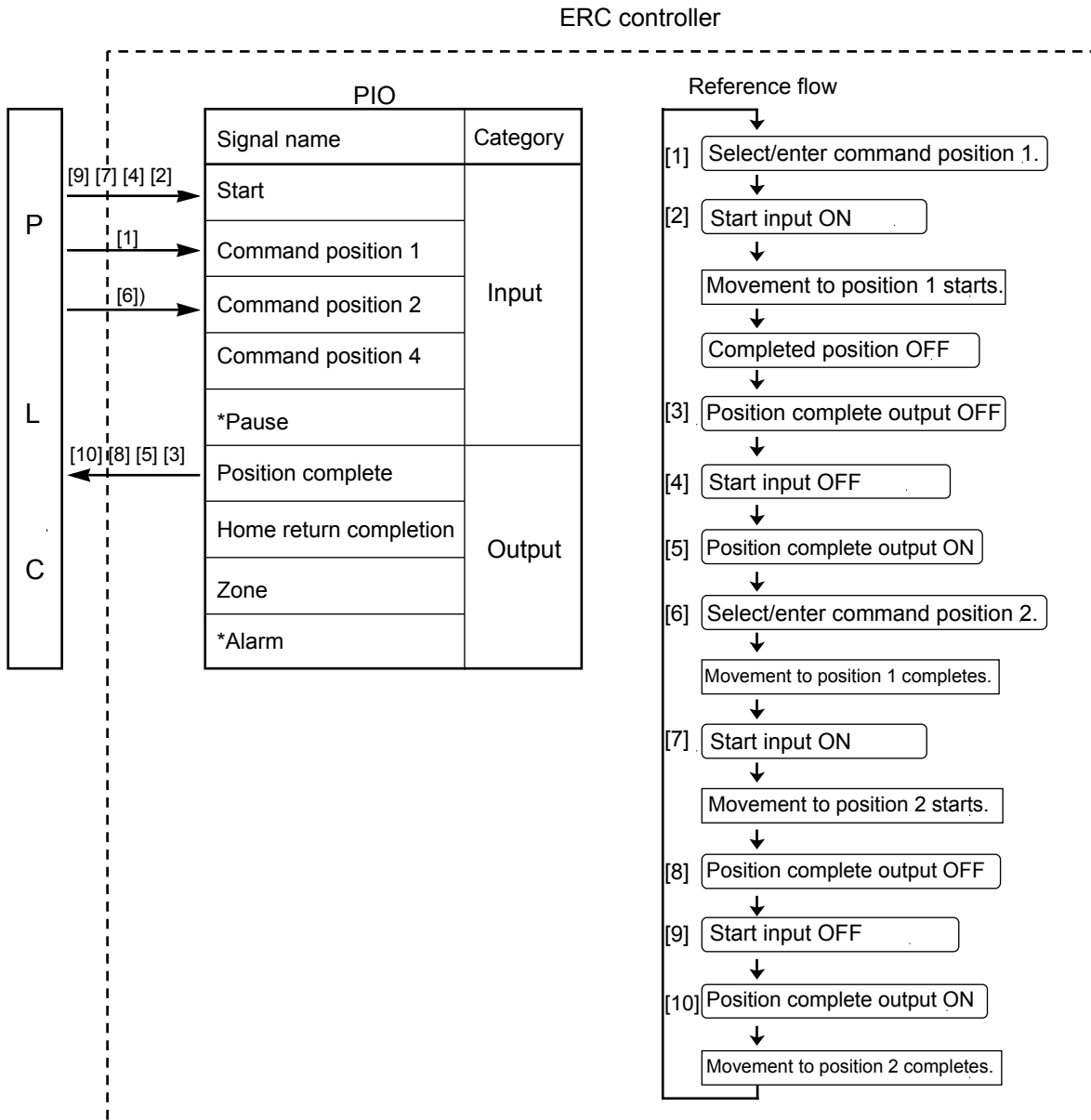

Position-data table (Field(s) within thick line must be entered.)

No.	Position	Speed	Acceleration/ deceleration	Push	Positioning band	Acceleration only MAX
0	*	*	*	*	*	*
1	250	200	0.3	0	0.1	0
2	100	100	0.3	0	0.1	0
⋮						

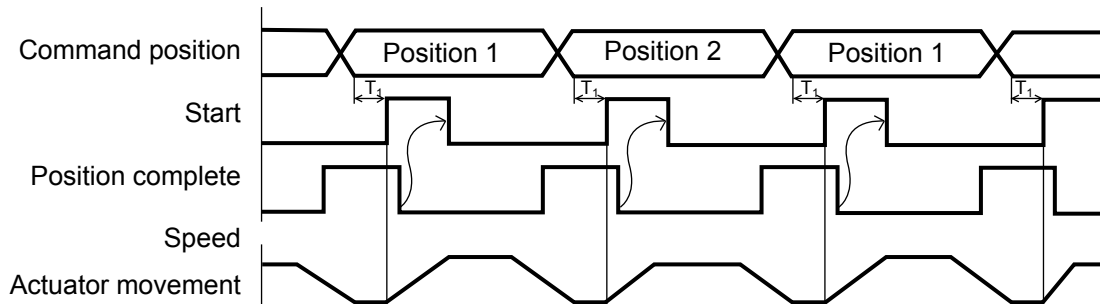

T1: 6 msec or more; time after selecting/entering a command position until the start input turns ON
(The scan time of the host controller must be considered.)

Each command position must be input after the position complete output has turned ON for the movement to the previous position.

Note: When the start signal turns ON, the position complete output will turn OFF.
The start signal must be turned OFF with the confirmation that the position complete output has turned OFF while the start signal remains ON.
If the start input remains ON as shown below, the position complete output will not turn ON even when the actuator movement is completed.

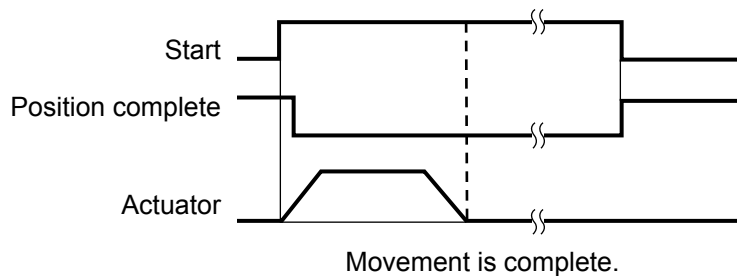

7.5 Push & Hold Mode

First, cause the position complete signal to turn ON by referring to 7.1, "How to Start."

Example of use in operation)

The actuator is caused to move back and forth in the push & hold mode and positioning mode. The position 280 mm from the home is set as position 1, and the position 40 mm from the home is set as position 2.

Movement to position 1 is performed in the push & hold mode (the actuator is caused to contact the load and push it in the counter-motor direction). The maximum push amount at position 1 is set as 15 mm, and the current-limiting value during the push & hold operation by the motor is set as 50%. Movement to position 2 is performed in the positioning mode. The travel speed to position 1 is set as 200 mm/sec, and that to position 2 is set as 100 mm/sec.

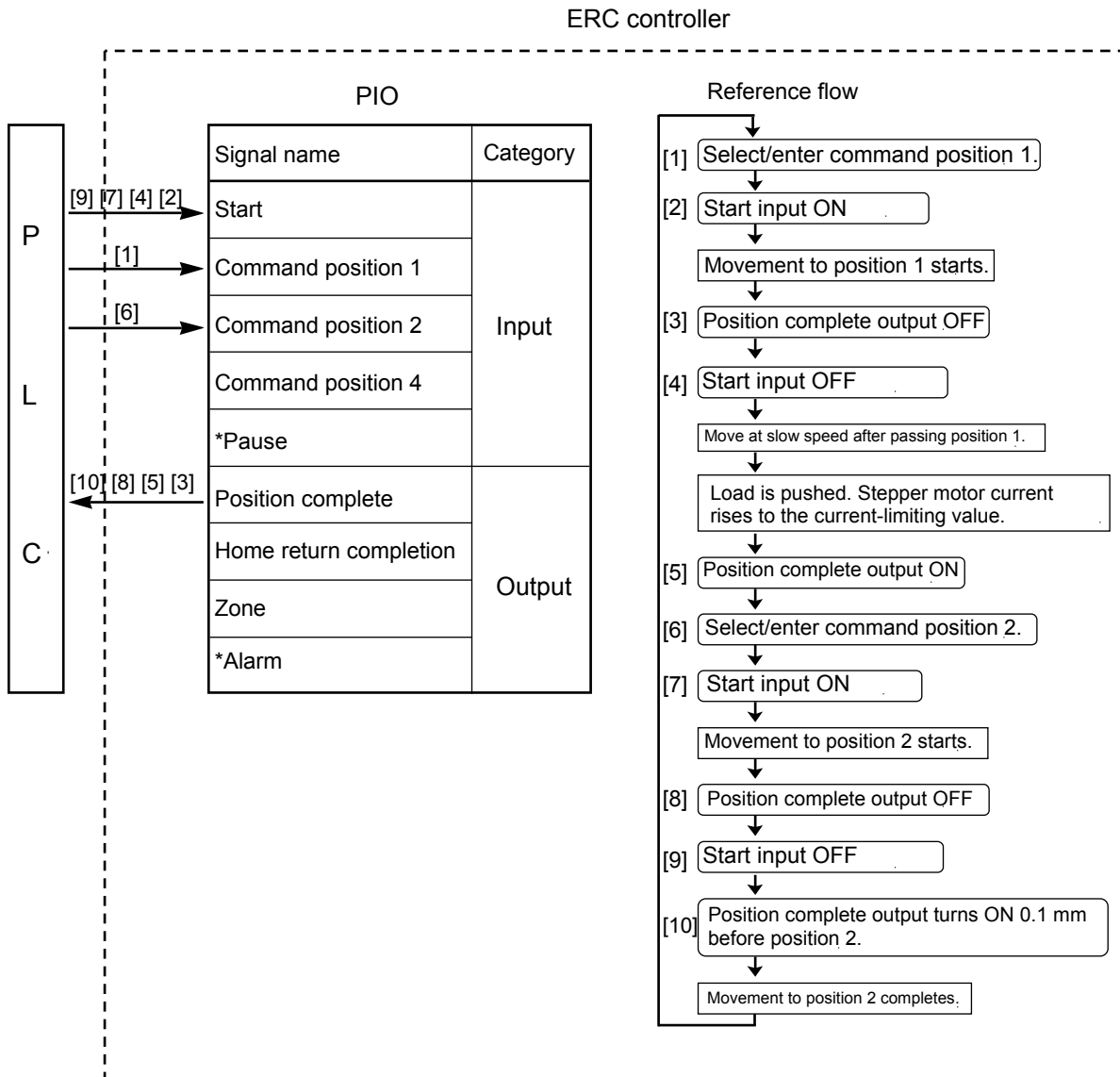

Position-data table (Field(s) within thick line must be entered.)

No.	Position	Speed	Acceleration/ deceleration	Push	Positioning band	Acceleration only MAX
0	*	*	*	*	*	*
1	280	200	0.3	50	15	0
2	40	100	0.3	0	0.1	0
⋮						

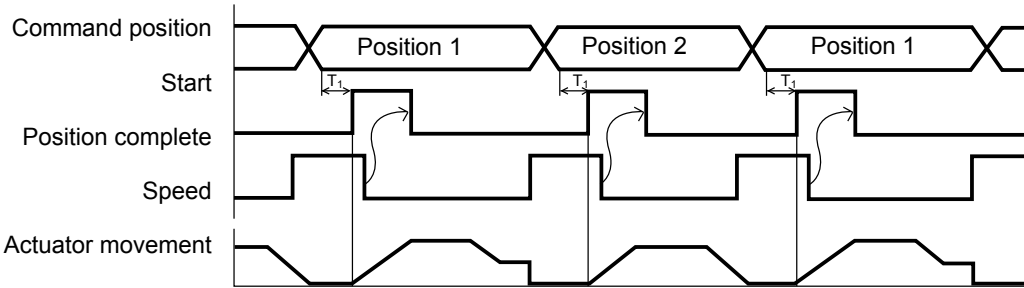

T1: 6 msec or more; time after selecting/entering a command position until the start input turns ON (The scan time of the host controller must be considered.)

Each command position must be input after the position complete output has turned ON for the movement to the previous position.

7.5.1 Return Action after Push & Hold by Relative Coordinate Specification

It should be noted that in a return action by relative coordinate specification, the reference position is not the current position at which the actuator is stopped after completing the push & hold. Rather, it is the target position specified in the position number with which the push & hold was executed.

In the above example, the actuator will move to the 240-mm position (280 – 40) if a relative coordinate of -40 mm is set in position No. 2.

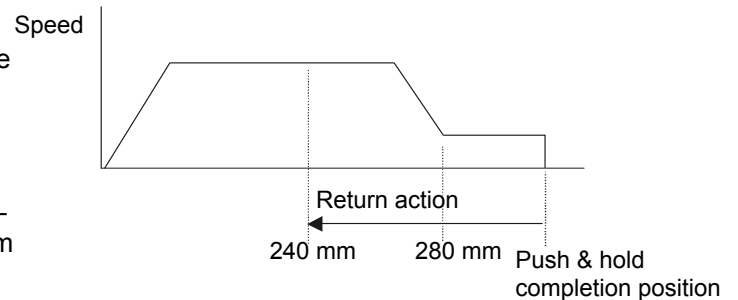

Note: When the start signal turns ON, the position complete output will turn OFF. The start signal must be turned OFF with the confirmation that the position complete output has turned OFF while the start signal remains ON. If the actuator has missed the load, the position complete output will not turn ON as shown below.

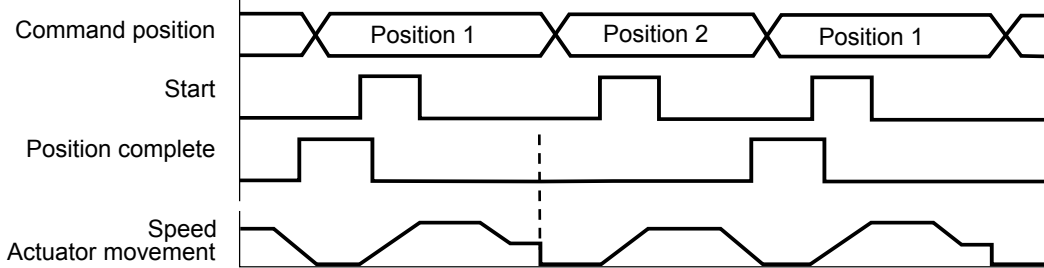

If the actuator has missed the load, the position complete output will not turn ON.

7.6 Speed Change during Movement

Example of use in operation) The actuator speed is reduced at a certain point during movement. The position 150 mm from the home is set as position 1, and the position 200 mm from the home is set as position 2. The actuator is initially located between the home and position 1. The actuator is moved to position 2 being the target position, at a travel speed of 200 mm/sec to position 1 and that of 100 mm/sec from position 1 to position 2.

Method) In this example, the actuator is caused to move to position 1 and to position 2 successively. Before the actuator is stopped at position 1, command position 2 must be selected/entered and the start signal must be input. To do this, set a wide positioning band at position 1 and cause the start signal for movement to position 2 to be input immediately after the completion signal for movement to position 1 is output. (Command position 2 should be entered while the actuator is moving to position 1.)

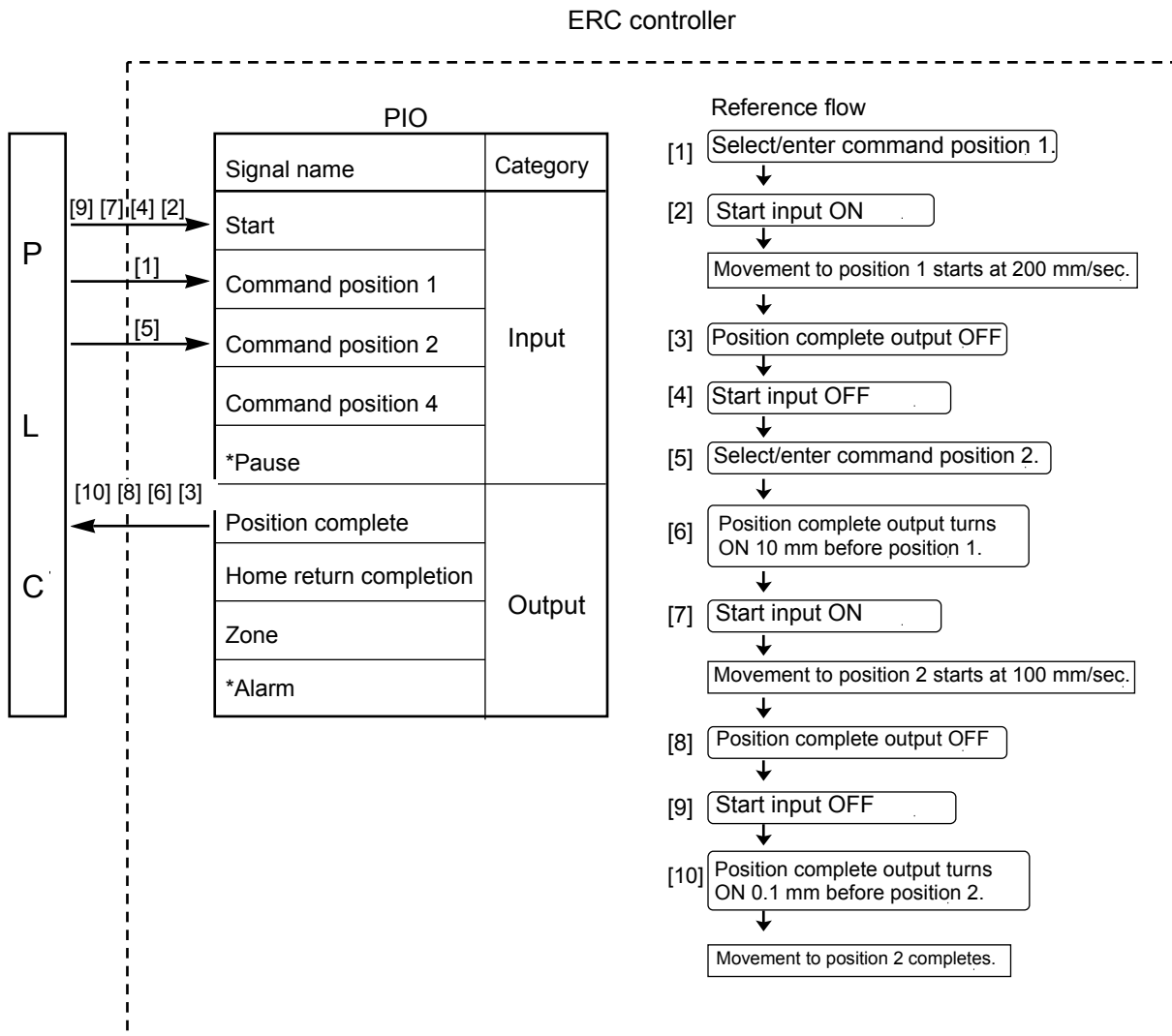

Position-data table (Field(s) within thick line must be entered.)

No.	Position	Speed	Acceleration/ deceleration	Push	Positioning band	Acceleration only MAX
0	*	*	*	*	*	*
1	150	200	0.3	0	10	0
2	200	100	0.3	0	0.1	0
⋮						

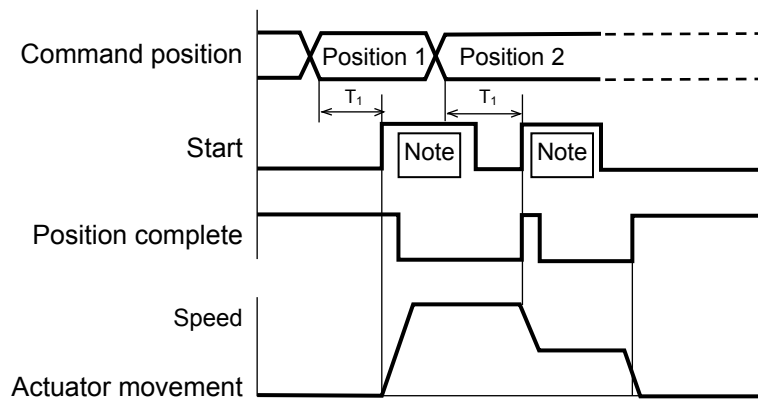

T1: 6 msec or more; time after selecting/entering a command position until the start input turns ON
(The scan time of the host controller must be considered.)

Note: When the start signal turns ON, the position complete output will turn OFF.
The start signal must be turned OFF with the confirmation that the position complete output has turned OFF while the start signal remains ON.

7.7 Operation at Different Acceleration and Deceleration Settings

Example of use in operation) Positioning is performed to the position 150 mm from the home (position 1) at a speed of 200 mm/sec. The actuator will accelerate at the maximum acceleration set according to the load, and decelerate at 0.1 G.

Method) Entering "1" under "Acceleration only MAX" in the position data will automatically adjust the acceleration to the maximum acceleration set according to the load. Entering "0.1" under "Acceleration/deceleration" in the position data will set the deceleration to 0.1 G.

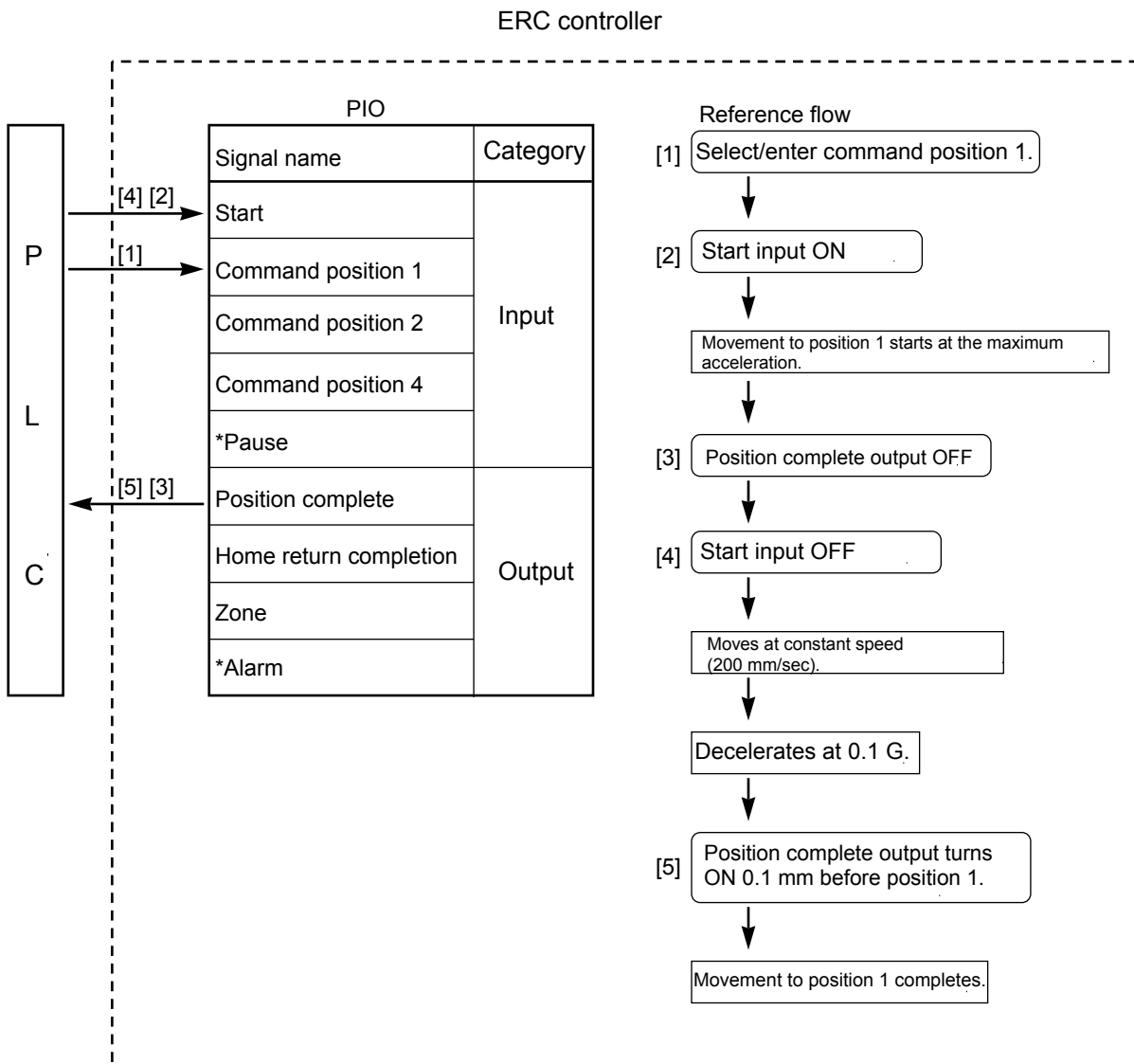

Position-data table (Field(s) within thick line must be entered.)

No.	Position	Speed	Acceleration/ deceleration	Push	Positioning band	Acceleration only MAX
0	*	*	*	*	*	*
1	150	200	0.1	0	0.1	1
⋮						

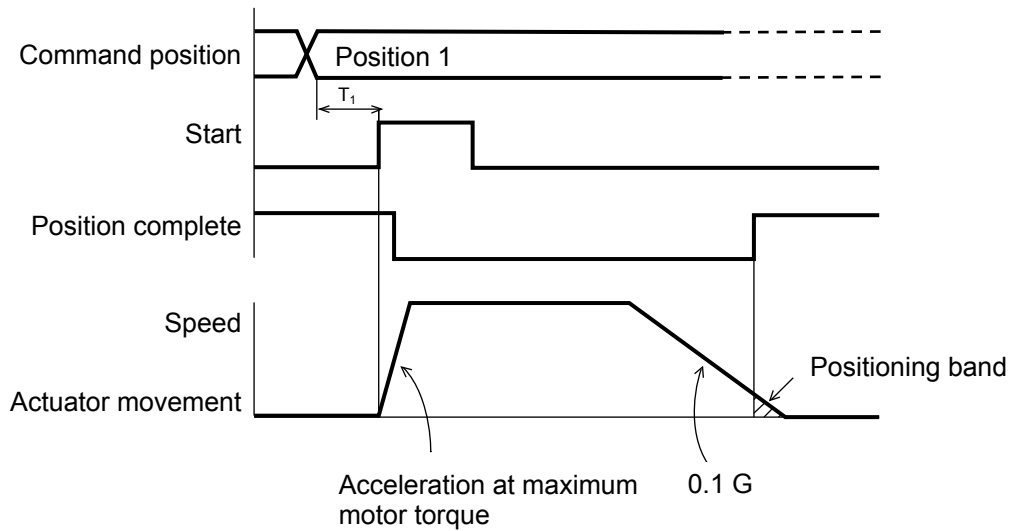

T1: 6 msec or more; time after selecting/entering a command position until the start input turns ON (The scan time of the host controller must be considered.)

Note: When the start signal turns ON, the position complete output will turn OFF. The start signal must be turned OFF with the confirmation that the position complete output has turned OFF while the start signal remains ON. If the start input remains ON as shown below, the position complete output will not turn ON even when the actuator movement is completed.

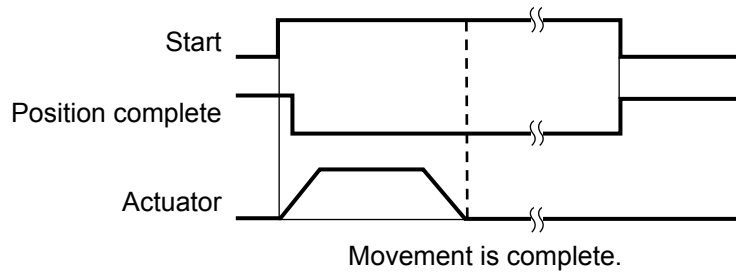

7.8 Pause

Example of use in operation) The actuator is paused during movement.
 Method) Use the pause input.

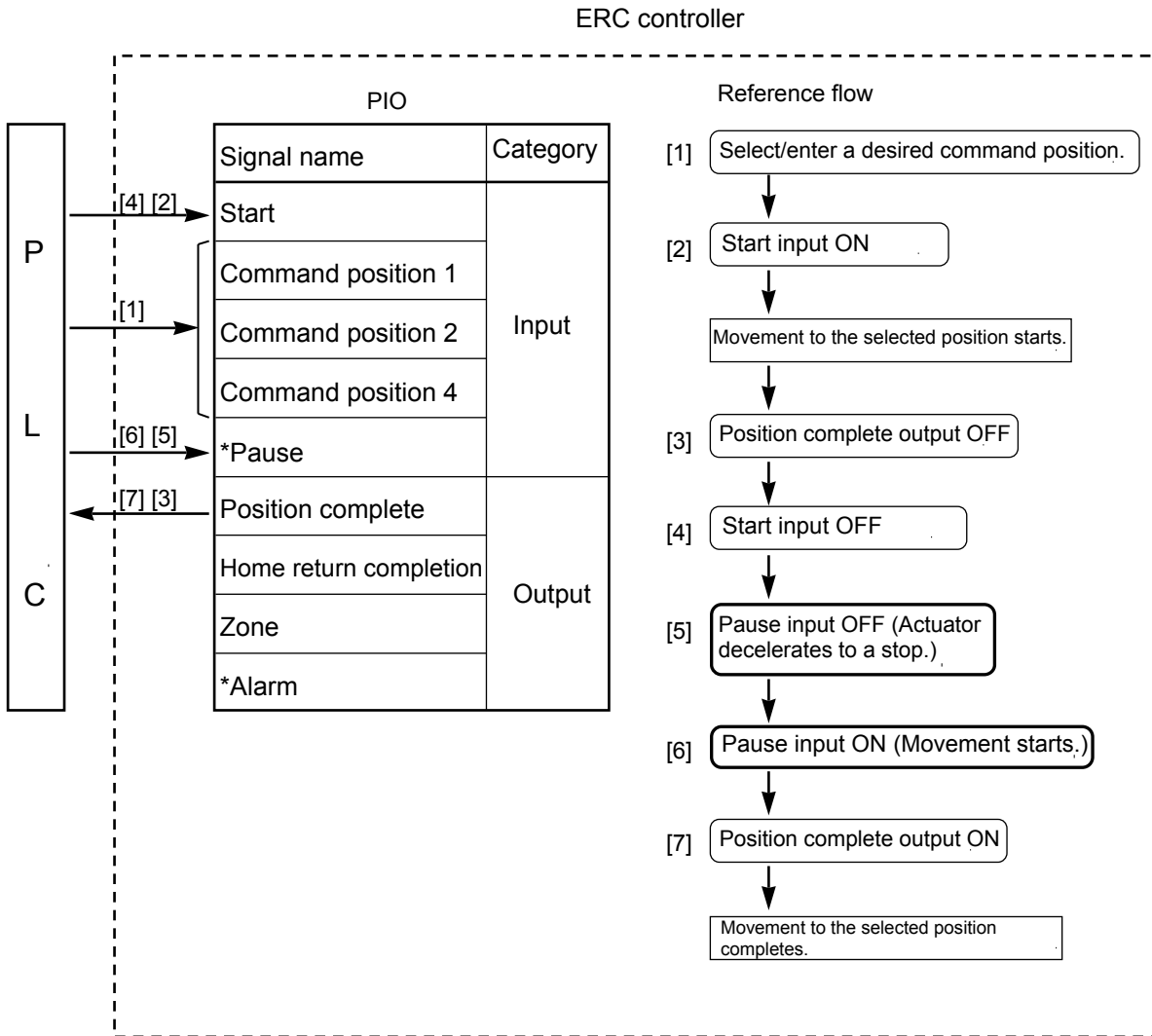

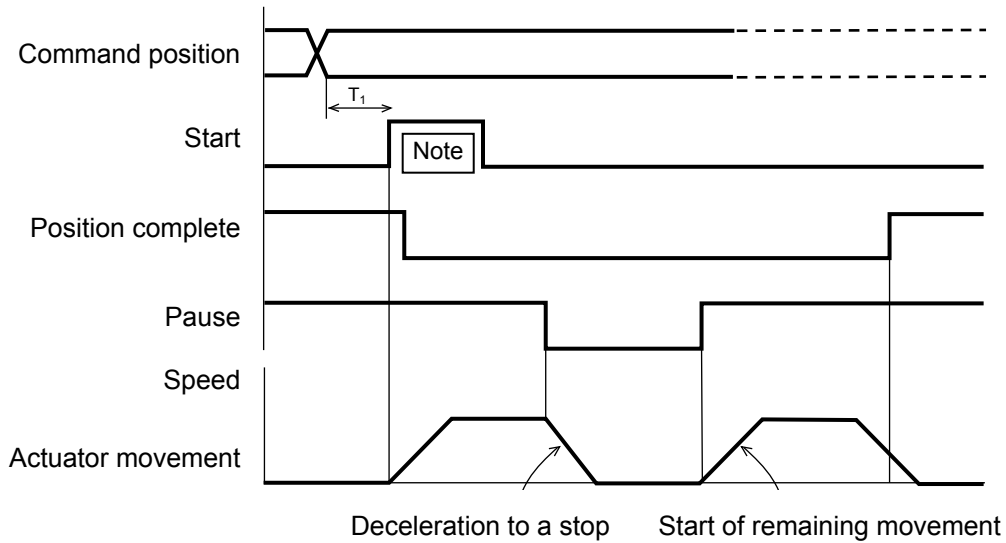

T1: 6 msec or more; time after selecting/entering a command position until the start input turns ON (The scan time of the host controller must be considered.)

Note: When the start signal turns ON, the position complete output will turn OFF. The start signal must be turned OFF with the confirmation that the position complete output has turned OFF while the start signal remains ON.

7.9 Zone Signal Output

Example of use in operation) While the actuator is moving a zone signal is output inside the zone enclosed by distances of 40 mm and 120 mm from the home. ($40\text{ mm} \leq \text{Zone signal output} \leq 120\text{ mm}$)

Method) Use the parameters “Zone boundary+” and “Zone boundary-” to set the zone in which the zone signal is output, as shown below:

Parameter No. 1	Zone boundary+	120
Parameter No. 2	Zone boundary-	40

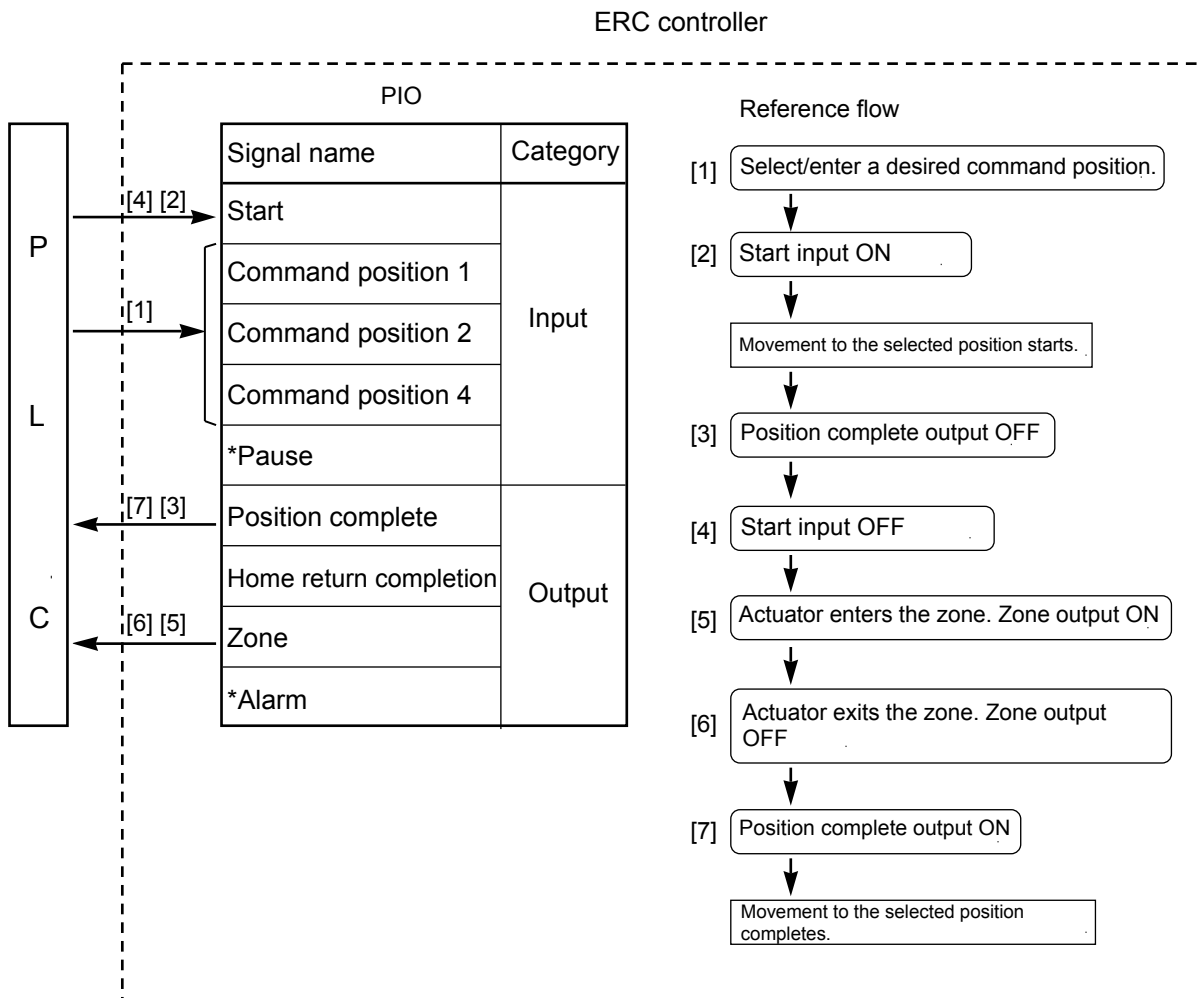

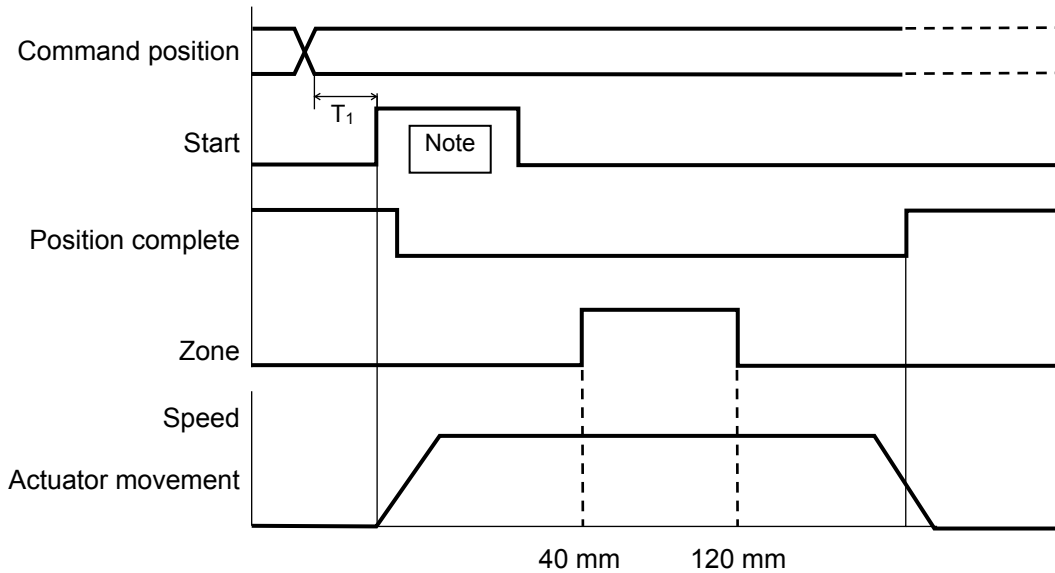

T1: 6 msec or more; time after selecting/entering a command position until the start input turns ON (The scan time of the host controller must be considered.)

Note: When the start signal turns ON, the position complete output will turn OFF. The start signal must be turned OFF with the confirmation that the position complete output has turned OFF while the start signal remains ON.

Example of other zone output)

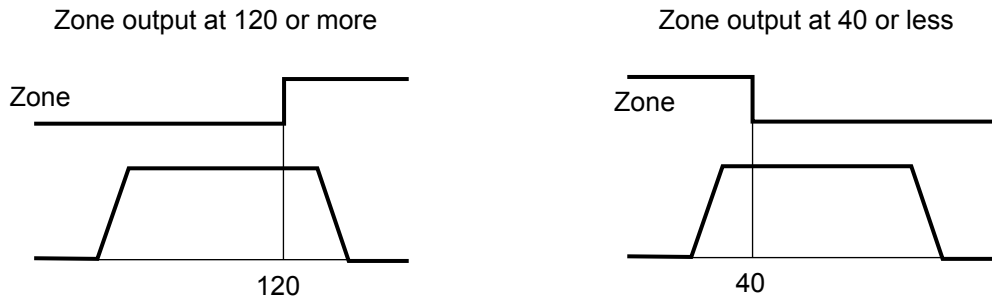

Zone boundary+	Maximum stroke length
Zone boundary-	120

Zone boundary+	40
Zone boundary-	0

7.10 Incremental Moves

Example of use in operation) The actuator is caused to move from the home to the 30-mm position, from which it will be moved repeatedly in increments of 10 mm. The travel speed from the home to the 30-mm position is set as 100 mm/sec, and that for 10-mm incremental moves is set as 20 mm/sec.

ERC controller

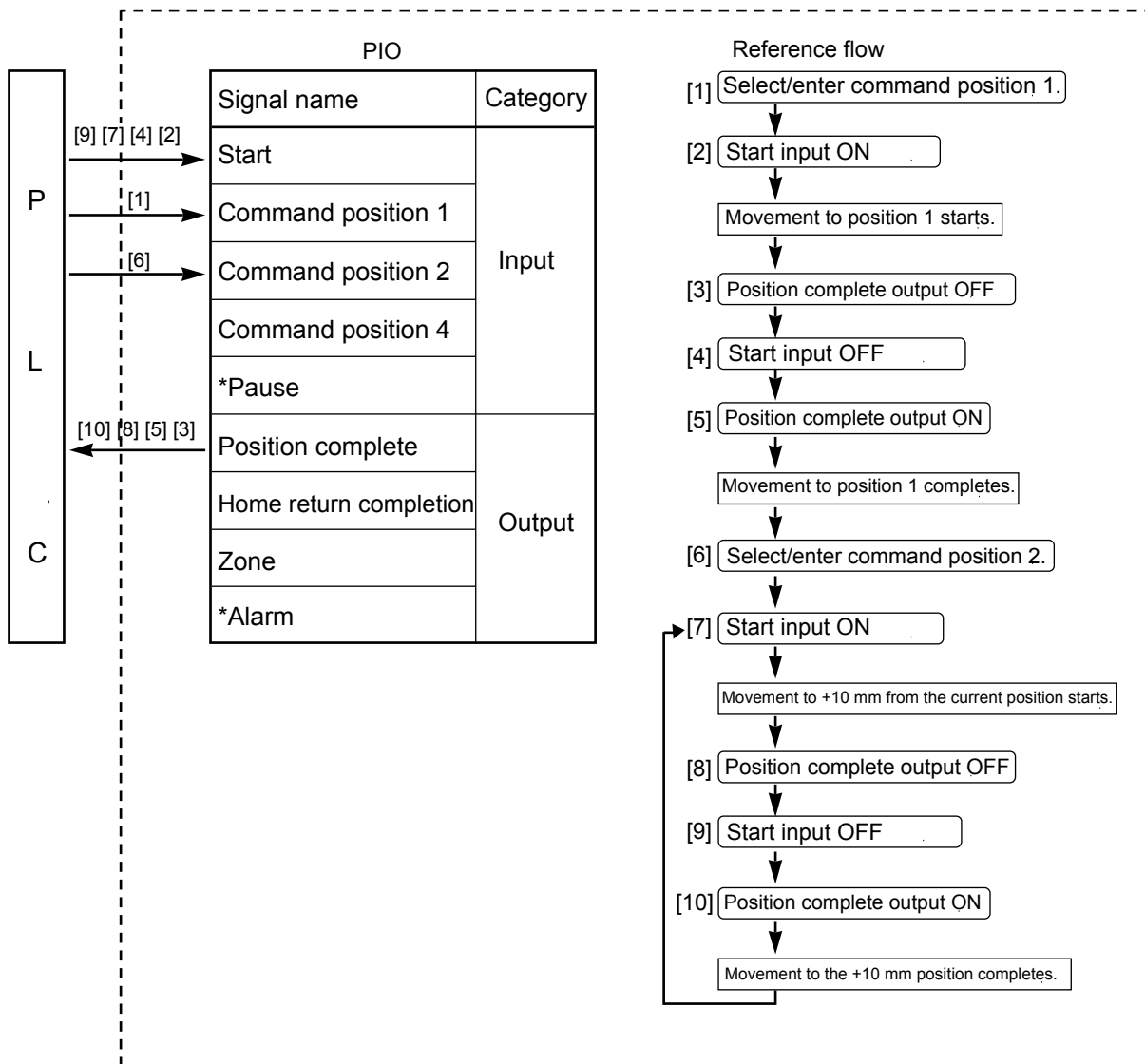

Position-data table (Field(s) within thick line must be entered.)

No.	Position	Speed	Acceleration/ deceleration	Push	Positioning band	Acceleration only MAX
0	*	*	*	*	*	*
1	30	100	0.3	0	0.1	0
2	10	20	0.3	0	0.1	0
⋮						

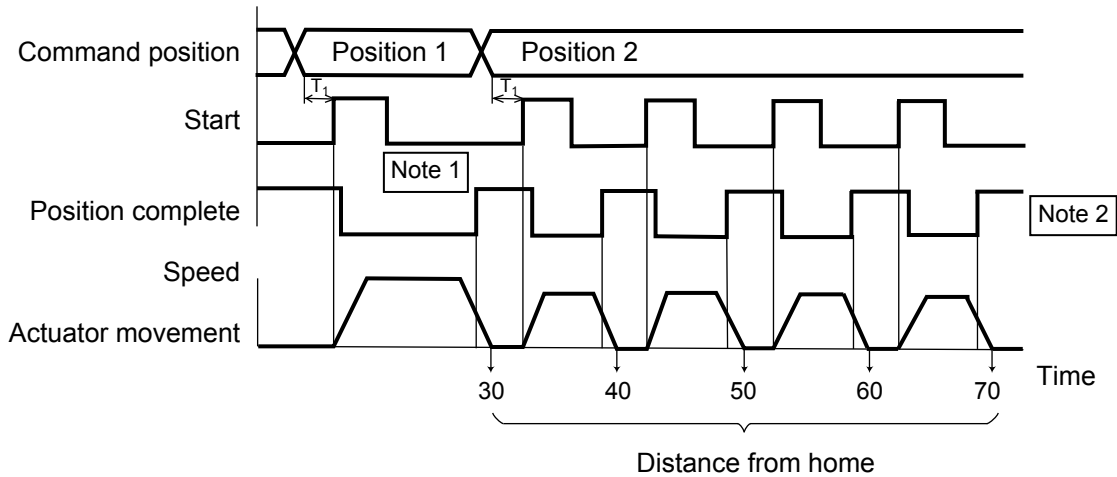

T1: 6 msec or more; time after selecting/entering a command position until the start input turns ON
(The scan time of the host controller must be considered.)

Note 1: When the start signal turns ON, the position complete output will turn OFF.
The start signal must be turned OFF with the confirmation that the position complete output has turned OFF while the start signal remains ON.
If the start input remains ON as shown below, the position complete output will not turn ON even when the actuator movement is completed.

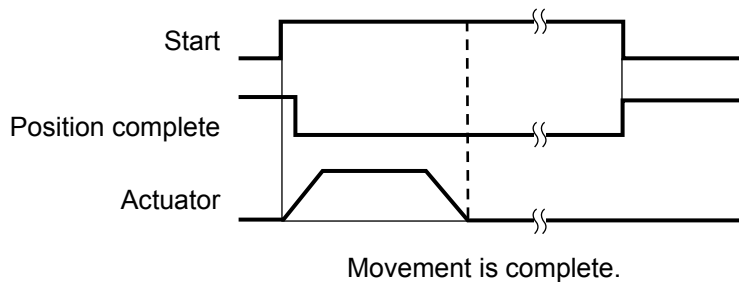

Note 2: When a soft limit is reached as a result of repeated incremental moves, the actuator will stop at that position and the position complete signal will be output.

7.11 Notes on Incremental Mode

(1) Notes on positioning operation

Selecting/entering a position number using relative coordinates during positioning will cause the actuator to move to the position corresponding to the initial position plus the increment. (If the increment is a negative value, the actuator will move to the position corresponding to the initial position minus the increment.)

Example) If the start signal for movement to position 2 is input while the actuator is moving to position 1, the actuator will move to the position 40 mm from the home.

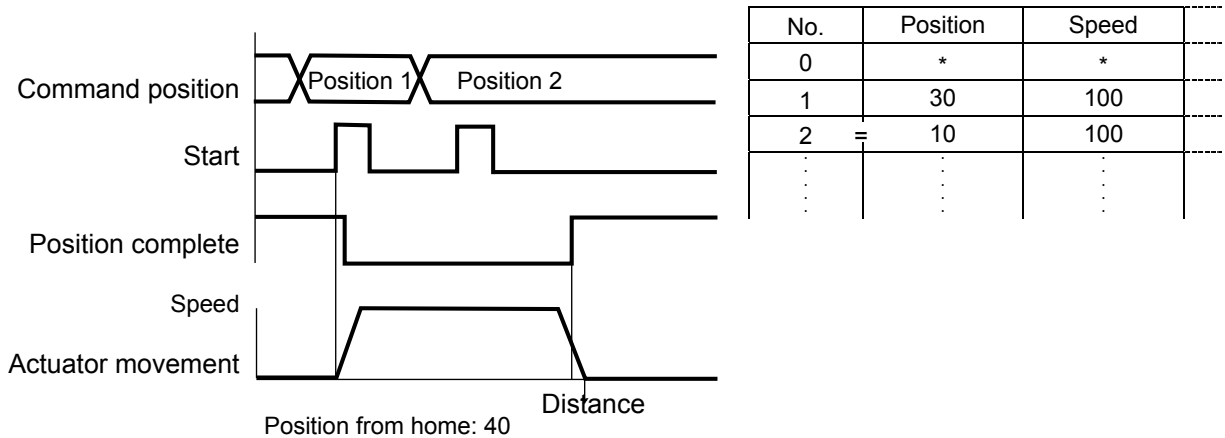

If the start signal for movement to an incremental position number is input multiple times during positioning, the actuator will move to the position corresponding to the initial position plus the “increment x number of times the signal was input.”

Example) If the start signal for movement to position 2 is input twice while the actuator is moving to position 1, the actuator will move to the position 50 mm from the home.

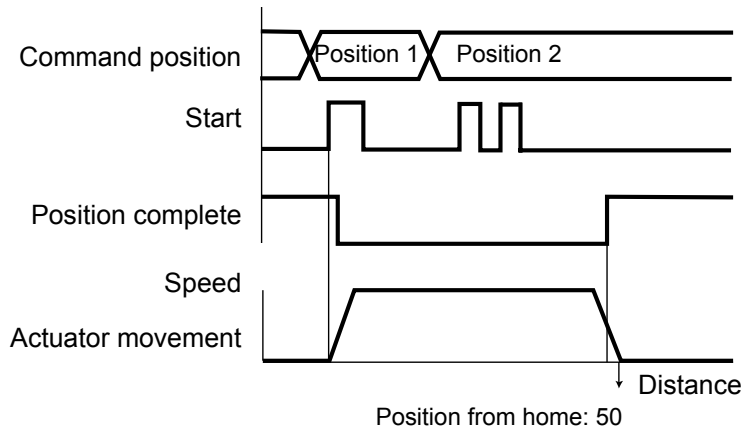

(2) Note on push & hold operation

If the start signal is input with an incremental position number selected/entered while the actuator is moving in the push & hold mode, the actuator will move to the position corresponding to the position at the time of start input plus the increment. Therefore, the end position will become indeterminate.

Example) If the start signal for movement to position 2 is input while the actuator is moving to position 1 in the push & hold mode, the actuator will move to the position 10 mm from where it was when the input signal was input.

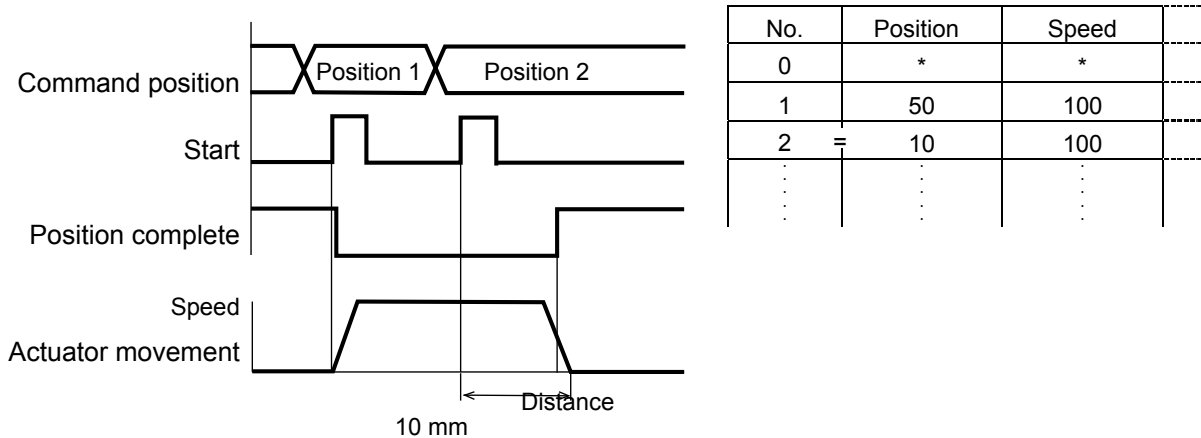

- (3) Cumulative errors due to repeated incremental moves
 Position data is recognized only as a multiple of the minimum resolution. The minimum resolution is determined by the lead and the number of encoder pulses. Therefore, a margin of error may occur between the entered position value and the actual movement of the actuator. If an incremental move is repeated, this error will accumulate.
 The maximum error range for each actuator type is shown below:

ERC model	Speed type	Lead [mm]	Maximum error range [mm]
ERC -SA6 -RA54 -RA54GS -RA54GD	Low speed	3	0.00375
	Medium speed	6	0.0075
	High speed	12	0.015
ERC -SA7 -RA64 -RA64GS -RA64GD	Low speed	4	0.005
	Medium speed	8	0.01
	High speed	16	0.02

Example) If an incremental move is repeated 10 times on an ERC-SA7/RA64 high-speed actuator, a maximum error of $0.02 \times 10 = 0.2$ [mm] may generate with respect to the final position.

To eliminate these cumulative errors, an absolute command must be executed before the error tolerance is exceeded.

- (4) Ball screw accuracy
 The accuracy of the ball screw used in the ERC conforms to C10 under the JIS standard.

8. Parameters

8.1 Parameter Classification

Parameters are classified into four types according to their content.

Category:

- a: Parameter relating to the actuator stroke range
- b: Parameter relating to the actuator operating characteristics
- c: Parameter relating to the external interface
- d: Servo gain adjustment

8.2 Parameter Table

No.	Category	Name	Unit	Default factory setting
1	a	Zone boundary 1+	mm	Effective actuator length
2	a	Zone boundary 1-	mm	Effective actuator length
3	a	Soft limit+	mm	Effective actuator length
4	a	Soft limit-	mm	Effective actuator length
5	a	Home return direction (0: [Reverse]/1: [Forward])	-	(In accordance with the specification at the time of order)
6	b	Push & hold stop judgment period	msec	255
7	d	Servo gain number	-	Set individually in accordance with the actuator characteristics.
8	b	Default speed	mm/sec	Set individually in accordance with the actuator characteristics.
9	b	Default acceleration/deceleration	G	Set individually in accordance with the actuator characteristics.
10	b	Default positioning band (in-position)	mm	0.10
11	b	Default acceleration only MAX flag	-	0
12	b	Current-limiting value at standstill during positioning	%	Set individually in accordance with the actuator characteristics.
13	b	Current-limiting value during home return	%	Set individually in accordance with the actuator characteristics.
14		(Reserved for future extension)		
15	c	Pause input disable selection (0: [Enable]/1: [Disable])	-	0
16	c	Serial communication speed	bps	38400
17	c	Minimum delay time for slave transmitter activation	msec	5
18		(Reserved for future extension)		
19		(Reserved for future extension)		
20		(Reserved for future extension)		
21		(Reserved for future extension)		
22	a	Home return offset	mm	Set individually in accordance with the actuator characteristics.
23		(Reserved for future extension)		
24		(Reserved for future extension)		
25	c	PIO pattern selection	-	0 (8 points)
26		(Reserved for future extension)		
27	c	Movement command type (0: [Level]/1: [Edge])	-	0 [Level]
28	b	Excited-phase signal detection direction [0: Reverse / 1: Forward]	-	Set individually in accordance with the actuator characteristics.

(Note) The numbers are displayed on the PC software screen but not on the teaching pendant. The category codes are provided only for convenience and not displayed on either the PC software screen or teaching pendant.

8.3 Parameter Settings

If a parameter has been changed, always restart the controller using a software reset command or by reconnecting the power.

8.3.1 Parameters Relating to the Actuator Stroke Range

● Soft limit

Set the soft limit in the positive direction in parameter No. 3, and that in the negative direction in parameter No. 4. The factory setting for the soft limits conforms to the effective actuator length. Change the settings, as necessary, to prevent crash with an obstacle or when the actuator must be stroked slightly beyond its effective length. A wrong soft limit setting will cause the actuator to crash into the mechanical end, so exercise due caution. The minimum setting unit is "0.01 [mm]."

(Note) To change a soft limit, set a value corresponding to 0.3 mm outside of the effective range.

Example) Set the effective range to between 0 mm and 80 mm
 Parameter No. 3 (positive side) 80.3
 Parameter No. 4 (negative side) -0.3

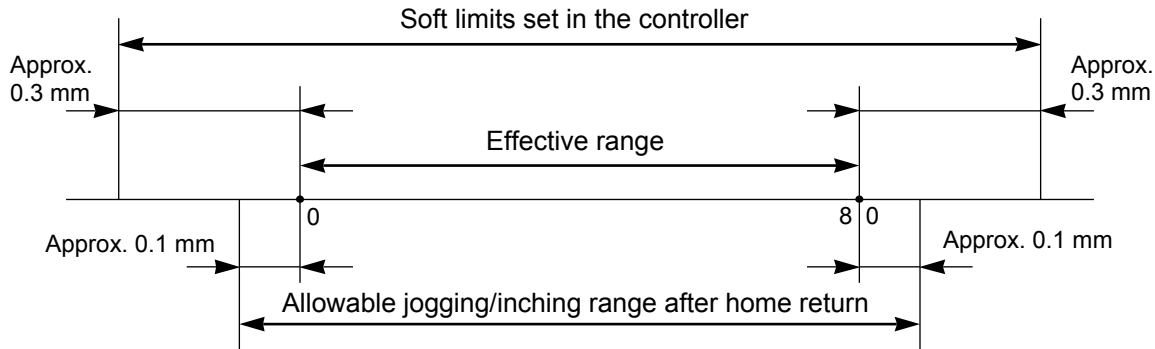

● Zone boundary

Set the zone in which a zone output signal (ZONE) will turn ON.

The zone signal turns ON only when the current coordinate position is inside the negative (-) boundary and positive (+) boundary settings.

The positive and negative boundaries for the ZONE signal are set in parameter No. 1 and No. 2, respectively.

The minimum setting unit is "0.01 [mm]."

Example) Use the zone output signal as an intermediate limit switch in the range of 100 to 200 mm, with an actuator having a 300-mm stroke
 Parameter No. 1 (positive side) 200, parameter No. 2 (negative side) 100

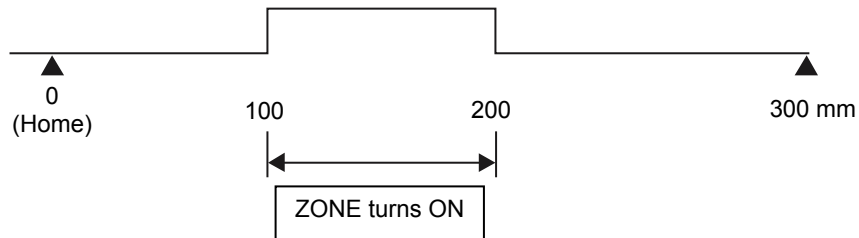

● Home return direction

Unless specified by the user, the home return direction is set to the motor direction at the factory. Should a need arise to change the home direction after the actuator has been assembled into your system, reverse the setting in parameter No. 5 between “0” and “1.” Also change the home return offset, if necessary. If necessary, also change the parameters for home return offset, soft limits and excited-phase signal detection direction.

Note: If the home direction is reversed, all position data that have been input will be cleared.

● Home return offset

The controller is shipped from the factory with an optimal value set in parameter No. 22, so the distance from each mechanical end to the home becomes uniform.

The minimum setting unit is “0.01 [mm].”

The home return offset can be adjusted in the following conditions:

- [1] Want to align the actuator home and the system’s mechanical home after the actuator has been assembled into the system
- [2] Want to set a new home after reversing the factory-set home direction
- [3] Want to eliminate a slight deviation generated after replacing the actuator

Note: If the home return offset has been changed, the soft limit parameters must also be adjusted accordingly.

8.3.2 Parameters Relating to the Actuator Operating Characteristics

● Default speed

The factory setting is the rated speed of the actuator.

When a target position is written to an unregistered position table, the setting in this parameter will be used as the speed data for the applicable position number.

To reduce the default speed from the rated speed, change the setting in parameter No. 8.

● Default acceleration/deceleration

The factory setting is the rated acceleration/deceleration of the actuator.

When a target position is written to an unregistered position table, the setting in this parameter will be used as the acceleration/deceleration data for the applicable position number.

To reduce the default acceleration/deceleration from the rated acceleration/deceleration, change the setting in parameter No. 9.

Type	Lead	Initial value
Slider	3 mm, 4 mm	0.2G
	6 mm or more	0.3G
Rod		0.2G

● Default positioning band (in-position)

The factory setting is “0.10 [mm].”

When a target position is written to an unregistered position table, the setting in this parameter will be used as the positioning band data for the applicable position number.

Increasing the default positioning band will allow the position complete signal to be output early. Change the setting in parameter No. 10, as necessary.

- Default acceleration only MAX flag

To cause the actuator to decelerate gradually when stopping, a lower acceleration/deceleration should be set. However, this will also reduce the acceleration.

This parameter allows for quick acceleration while reducing the deceleration.

However, the actual load must be one-third the rating or less.

Check the payload rating by referring to 1.3, “Specifications.”

The factory setting is “0: [Disable].”

When a target position is written to an unregistered position table, the setting in this parameter will be used as the acceleration only MAX data for the applicable position number.

To enable the default value, change parameter No. 11 to “1: [Enable].”

- Push & hold stop judgment period

This parameter is used as a judgment condition when determining if the load was contacted and the push & hold operation has completed.

The push & hold operation is judged complete if the current-limiting value set in the position table has been maintained for the period set in parameter No. 6.

Set an optimal value by considering the shape and strength of the load, as well as the current-limiting value.

The minimum setting unit is “1 [msec],” and the maximum judgment period is “255 [msec].” The factory setting is “255 [msec].”

(Note) If the load has shifted and the current has changed during the push & hold judgment, the judgment follows the timing chart shown below. This example assumes a judgment period of 255 msec.

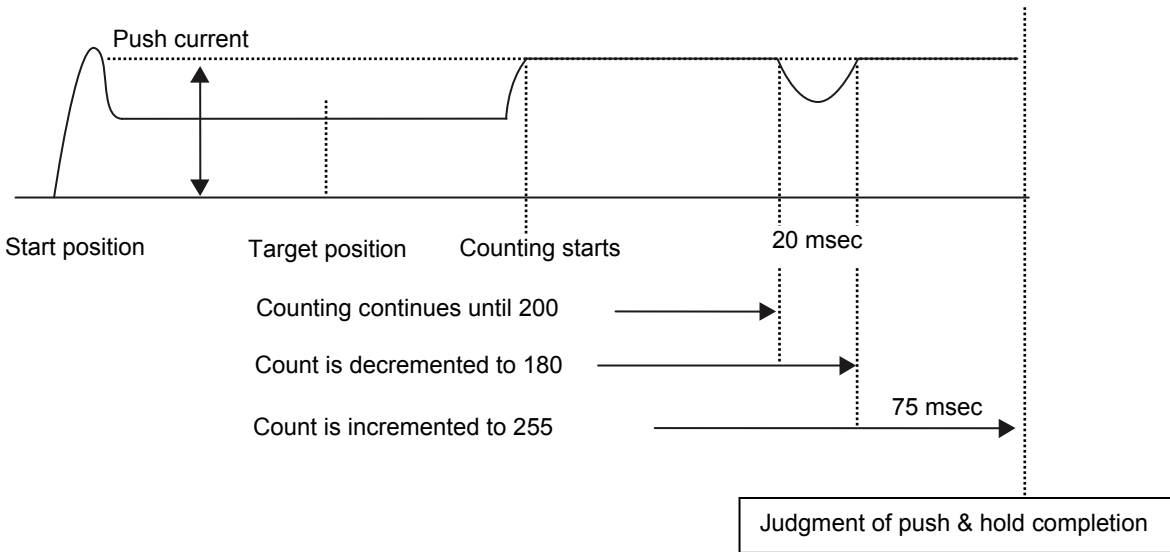

After reaching the push current, it is maintained for 200 msec. The current drops during the subsequent 20-msec period, and accordingly the count is decremented by 20. Therefore, when the operation is resumed the count will start from 180. Since the count will reach 255 after 75 msec at the push current, the controller will determine that the push & hold operation has completed.

In this example, the total judgment period is 295 msec.

- Current-limiting value at standstill during positioning

The factory setting conforms to the standard specification of the actuator.

Increasing this setting will increase the holding torque at standstill.

This setting need not be changed in normal conditions of use. However, to prevent hunting caused by large external force applied while the actuator is at standstill, the value set in parameter No. 12 must be increased.

(Do not increase the value beyond 70%.)

- Current-limiting value during home return

The factory setting conforms to the standard specification of the actuator.

Increasing this setting will increase the home return torque.

This setting need not be changed in normal conditions of use. However, if an increased slide resistance causes the home return to complete before the correct position depending on the affixing method, load condition or other factor when the actuator is used in a vertical application, the value set in parameter No. 13 must be increased. (Do not increase the value beyond 75%.)

- Excited-phase Signal Detection Direction

Following the power on, excited-phase detection is performed when the servo turns on for the first time. This parameter defines the direction in which this detection is performed.

Normally this parameter need not be changed. In certain situations, such as when the actuator is contacting the mechanical end or other obstruction when the power is turned on and cannot be moved by hand, change the setting to the direction in which the motor can run easily.

To set a desired direction, set 0 or 1 in parameter No. 28, as applicable. If the detection direction is the same as the home return direction, set the same value currently specified in parameter No. 5 [Home return direction].

To set the direction opposite the home return direction, set the value different from what is currently specified in parameter No. 5 [Home return direction].

(Example 1) The power is turned on when the slider, installed vertically with the motor at the top, is contacting the bottom mechanical end.

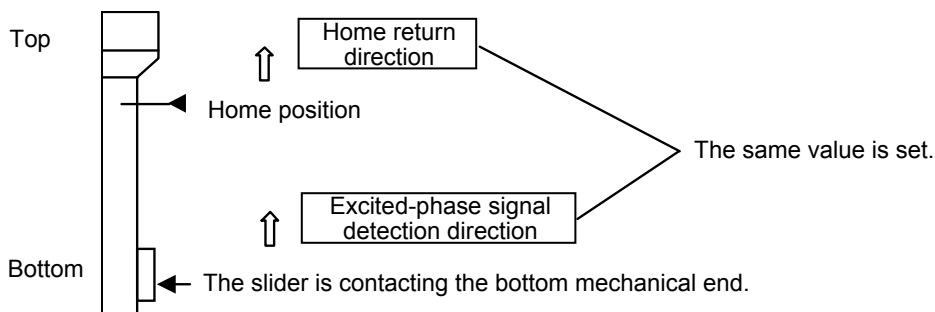

(Example 2) The power is turned on when the slider, installed vertically with the motor at the bottom, is contacting the bottom mechanical end.

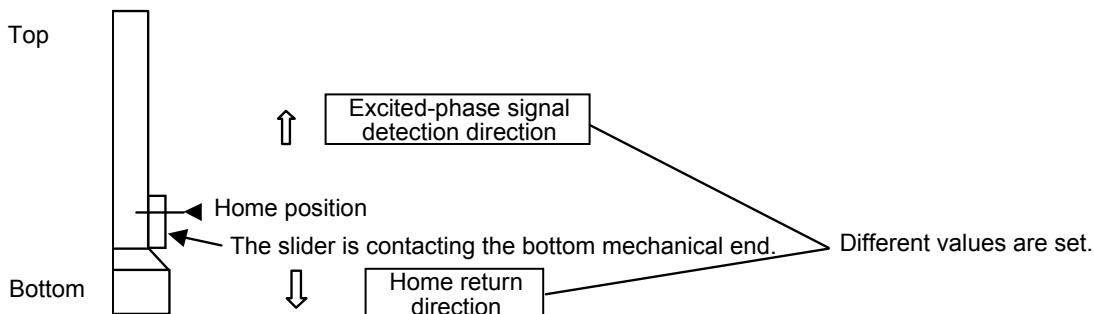

* This parameter is effective in PC software version 5.0.1.0 or later, as well as teaching pendant version 1.67 or later for [RCA-T], version 1.67 or later for [RCA-E/P] and version 1.04 or later for [RCB-J].

8.3.3 Parameters Relating to the External Interface

- PIO pattern selection

Select a desired PIO operation pattern using parameter No. 25.

This parameter sets the basis of operation, so be sure to set it first.

The factory setting is “0: [8 points].”

Setting of parameter No. 25	Feature of the PIO pattern
0	8 points The basic pattern providing eight positioning points.
1	3 points (air cylinder) Use of the ERC as an air cylinder is assumed in this pattern. The number of positioning points is limited to three, but a direct command input and a position complete output are provided for each target position in line with the conventional practice of air cylinder control. This lets the user control the ERC just like an air cylinder.
2	16 points The number of positioning points is increased to 16. However, the home return input is not provided.

- Movement command type

When the PIO pattern is set to “3 points,” define the operation condition of the movement command input (ST0 to ST2) in parameter No. 27.

The factory setting is “0: [Level mode].”

Description of the movement command input	Setting
Level mode: The actuator starts moving when the input signal turns ON. When the signal turns OFF during the movement, the actuator will decelerate to a stop and complete its operation, thereby returning to the initial mode.	0
Edge mode: The actuator starts moving when the rise edge of the input signal is detected. The actuator will not stop even when the signal turns OFF during the movement, until the target position is reached.	1

[Level mode]

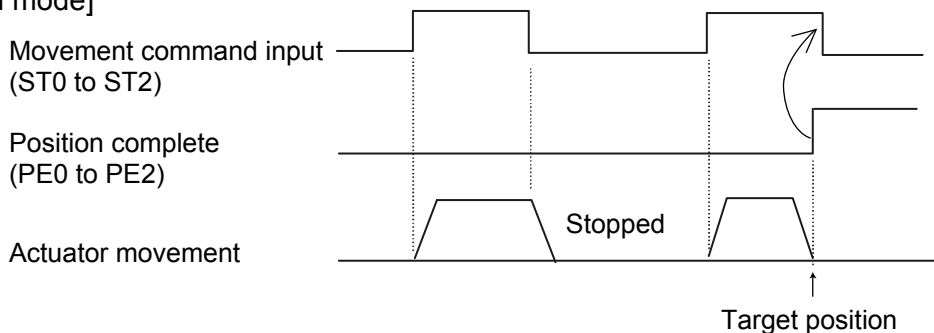

(Note) Turn OFF the movement command input after confirming that the target position has been reached.

[Edge mode]

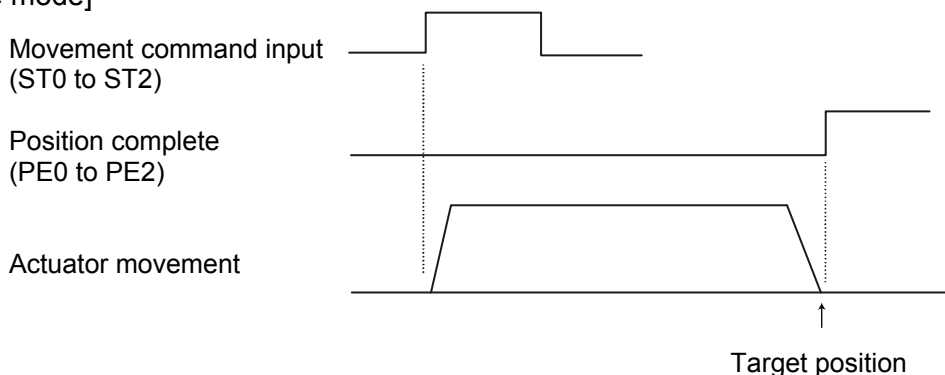

● Pause input disable selection

Parameter No. 15 defines whether the pause input signal is disabled or enabled.

	Setting
Enable (use) the signal	0
Disable (do not use) the signal	1

The factory setting is "0: [Enable]."

● Serial communication speed

Set the communication speed to be used when the control is performed via serial communication using the PLC's communication module.

Set an appropriate value in parameter No. 16 in accordance with the specification of the communication module. One of 9600, 19200, 38400 and 115200 bps can be selected as the communication speed.

The factory setting is "38400 [bps]."

● Minimum delay time for slave transmitter activation

This parameter defines the minimum delay until the controller's transmitter will be activated after completion of command reception, when serial communication is performed using the PLC's communication module.

The factory setting is "5 [msec]," but other necessary delay time must be set in parameter No. 17 if the specification of the communication module exceeds 5 msec.

8.3.4 Servo Gain Adjustment

- Servo gain number

The factory setting is optimized in accordance with the standard specification of the actuator.

This setting need not be changed in normal conditions of use. However, an increased load may produce noise during downward movements depending on the affixing method, load condition or other factor when the actuator is used in a vertical application. In this case, decreasing the value set in parameter No. 7 will be effective. However, do not decrease the value below “3” to maintain an overall balance with the actuator.

9. Troubleshooting

9.1 Action to Be Taken upon Occurrence of Problem

Upon occurrence of a problem, take appropriate action according to the procedure below in order to ensure speedy recovery and prevent recurrence of the problem.

- a) Check the status indicator lamps.
 Illuminating in green --- The servo is ON.
 Illuminating in red --- An alarm is present or the motor drive power is cut off.
- b) Check for error in the host controller.
- c) Check the voltage of the main 24-VDC power supply.
- d) Check for alarm.
 Confirm the details of error on the PC or teaching pendant.
- e) Check the cables for connection error, disconnection or pinching.
 Before performing a continuity check, turn off the power (to prevent a runaway actuator) and disconnect the cables (to prevent accidental power connection due to a sneak current path).
- f) Check the I/O signals.
- g) Check the noise elimination measures (grounding, installation of surge killer, etc.).
- h) Review the events leading to the occurrence of problem, as well as the operating condition at the time of occurrence.
- i) Check the serial numbers of the actuator.
- j) Analyze the cause.
- k) Take action.

Please check items a) through i) before contacting IAI.

9.2 Alarm Level Classification

Alarms are classified into three levels according to the symptoms they represent.

Alarm level	LED color	*ALM signal	What happens when alarm generates	How to reset
Message	Green	Not output	An error is displayed on the PC or teaching pendant.	
Operation cancellation	Red	Output	The actuator decelerates to a stop and then the servo turns OFF.	Reset the alarm on the PC/teaching pendant.
Cold start	Red	Output	The actuator decelerates to a stop and then the servo turns OFF.	Reconnect the power.

(Note) Reset each alarm after identifying and removing the cause. If the cause of the alarm cannot be removed or when the alarm cannot be reset after removing the cause, please contact IAI.
 If the same error occurs again after resetting the alarm, it means the cause of the alarm has not been removed.

9.3 Alarm Description and Cause/Action

(1) Message level alarms

Code	Error name	Cause/Action
41	Motor voltage drop	This alarm indicates that the motor drive power is cut off. (This is not an error.)
5A	Reception overrun	This alarm indicates an error during PC or teaching pendant operation or in the serial communication using the PLC's communication module. Cause: [1] Garbage data due to the effect of noise [2] Duplicate slave numbers when multiple controllers are controlled by serial communication [3] When a SIO converter is used, a teaching pendant and a PC are connected at the same time. Action: [1] Adjust the wiring in a manner eliminating the effect of noise and review the installation of equipment, etc. [2] Change the slave numbers to avoid duplication. [3] Connect either of them.
5B	Reception framing error	
5D	Header error	
5E	Delimiter error	
7F	BCC error	
61	FNCCHR, W address error	This alarm indicates an error in the serial communication using the PLC's communication module. Cause: Undefined command or out-of-range data Action: Review the transmitted data and correct the format.
62	Operand 1 error	
63	Operand 2 error	
64	Operand 3 error	
65	EEPROM write timeout	Cause: Writing of parameter or position data to the nonvolatile memory area does not complete within 200 ms. (This alarm will not generate in normal operation.) Action: Do not write data from the PC or teaching pendant simultaneously while a command is being issued from the PLC.
70	Movement command during RUN-OFF	Cause: A movement command was issued while the motor drive power was cut off. Action: Issue a movement command after deactivating the safety circuit to supply the motor drive power.
73	Error reset during servo ON	Cause: An alarm reset command was sent while the servo was ON during an operation by serial communication. (PIO commands are excluded.) Action: Send an alarm reset command after confirming that the servo is OFF.
75	Movement command during home return	Cause: The next movement command was issued during home return. Action: Issue the next movement command after confirming that the home return has completed (HEND is ON).
76	Soft reset during servo ON	Cause: A soft reset command was sent while the servo was ON during an operation by serial communication. (PIO commands are excluded.) Action: Send a soft reset command after confirming that the servo is OFF.

(2) Operation-cancellation level alarms

Code	Error name	Cause/Action
B0	Bank 30 data error	<p>Cause: Data in the parameter area is outside the input range or invalid. (This alarm will not generate in normal parameter input operation, but may occur during serial communication using the PLC's communication module.)</p> <p>Action: Transfer data after confirming that the parameter values are valid.</p>
B1	Bank 31 data error	<p>Cause: [1] A movement command was issued by selecting a number to which no position data was registered. [2] Position data value exceeds the soft limit setting. [3] The position number was recognized wrongly due to an unstable start signal or insufficient signal input period.</p> <p>Action: [1] Revise the sequence in such a way that unregistered position numbers will not be selected. [2] Change the position data to a value inside the soft limit settings. [3] The minimum timer setting may not be recognized depending on the PLC. Pay attention to the timer setting.</p>
BE	Home return timeout	<p>Cause: Home return does not complete within the period set in the applicable system parameter after the start of home return operation.</p> <p>Action: This alarm will not generate in normal operation. Should you encounter the alarm, please contact IAI.</p>
C0	Excessive actual speed	<p>Cause: This alarm indicates that the motor speed exceeded the maximum speed set in the applicable system parameter. This alarm will not generate in normal operation, but may occur in the following conditions: [1] Large actuator slide resistance in certain area, or [2] Instantaneous increase in load due to application of external force, which may cause the load to decrease and actuator to move rapidly before a servo error is detected.</p> <p>Action: Check for abnormality in the assembly condition of mechanical parts. If the actuator is suspected to be the cause, please contact IAI.</p>
C1	Servo error	<p>This alarm indicates that after receiving a movement command the motor is unable to operate for two seconds or more before reaching the target position.</p> <p>Cause: [1] Brake cannot be released on a controller equipped with brake. [2] Large load due to application of external force [3] Large slide resistance of the actuator itself</p> <p>Action: [1] Turn on/off the brake release switch to see if the brake makes "click" sounds. [2] Check for abnormality in the assembly condition of mechanical parts. [3] If the load capacity is normal, cut off the power and move the actuator by hand to check the slide resistance. If the actuator is suspected to be the cause, please contact IAI.</p>
C9	Excessive motor supply voltage	<p>This alarm indicates that the motor supply voltage is excessive (24 V + 20%: 28.8 V or more).</p> <p>Cause: [1] High voltage of the 24-V input power supply [2] Faulty controller board component</p> <p>Action: Check the voltage of the input power supply. If the voltage is normal, please contact IAI.</p>

Code	Error name	Cause/Action
CA	Overheating	This alarm indicates that the temperature around the power transistor in the controller board is too high (95°C or higher). Cause: [1] High temperature around the actuator [2] Faulty part inside the controller board Action: Reduce the temperature around the actuator. If the temperature around the actuator is normal, please contact IAI.
CC	Abnormal control supply voltage	This alarm indicates that the voltage of the 24-V input power supply is excessive (24 V + 20%: 28.8 V or more). Cause: [1] High voltage of the 24-V input power supply [2] Faulty part inside the controller board Action: Check the voltage of the input power supply. If the voltage is normal, please contact IAI.
CE	Drop in control supply voltage	This alarm indicates that the voltage of the 24-V input power supply has dropped (24 V – 20%: 19.2 V or less). Cause: [1] Low voltage of the 24-V input power supply [2] Faulty part inside the controller board Action: Check the voltage of the input power supply. If the voltage is normal, please contact IAI.

(3) Cold-start level alarms

Code	Error name	Cause/Action
B8	Excitation detection error	This actuator detects the excited phase when the servo is turned ON for the first time following the power ON. This error indicates that the specified encoder signal level cannot be detected within 100 ms of excitation. Cause: [1] The brake cannot be released (if the actuator is equipped with a brake). [2] A large load is applied due to an external force. [3] The power was turned on when the actuator was contacting a mechanical end. [4] The slide resistance of the actuator itself is large. Action: [1] Turn on/off the brake release switch to see if the brake makes “click” sounds. [2] Check for abnormality in the assembly condition of mechanical parts. [3] Move the actuator away from the mechanical end, and then turn on the power again. [4] If the load capacity is normal, cut off the power and move the actuator by hand to check the slide resistance. If the actuator is suspected to be faulty, please contact IAI.
F8	Damaged nonvolatile memory	Abnormal data was detected during the nonvolatile memory check after starting. Cause: [1] Faulty nonvolatile memory [2] The memory has been rewritten more than 100,000 times. (The nominal rewrite limit of the nonvolatile memory is around 100,000 times.) Action: If the alarm generates again after reconnecting the power, please contact IAI.
FA	CPU error	The CPU is not operating properly. Cause: [1] Faulty CPU [2] Malfunction due to noise Action: If the alarm generates again after reconnecting the power, please contact IAI.

9.4 Messages Displayed during Operation Using the Teaching Pendant or PC Software

This section explains the warning messages that may be displayed during operation using the teaching pendant or PC software.

Code	Error name	Cause/Action
112	Invalid data	An inappropriate value was entered in a user parameter. (Example) 9601 was entered as the serial communication speed by mistake. Enter an appropriate value again.
113 114	Value too small Value too large	The entered value is smaller than the setting range. The entered value is larger than the setting range. Refer to the actuator specifications or parameter table and enter an appropriate value again.
115	Home return non-completion	The current position was written when home return was not yet completed. Execute home return again.
116	Last position data	Data already exists in the last position area of the position table when new data is added. Clear or delete the current last position data first.
117	No movement data	Target position is not set under the selected position number. Enter the target position first.
11E	Paired data mismatch	The values indicating the magnitude relationship of a pair of data are inappropriate. (Example) The same value was entered in both the parameters for + and – soft limits. Enter appropriate values again.
11F	Absolute position too small	The minimum movement toward the target position is determined by the lead length of the drive system and resolution of the encoder. This message indicates that the entered target value is smaller than the minimum movement. (Example) If the lead length is 16 mm, the encoder's resolution is 800 pulses and accordingly the minimum movement becomes $16 \div 800 = 0.02$ mm/pulse. In this case, this message will be displayed if 0.01 mm is entered as the target position.
121	Push & hold search end over	The final position in push & hold operation exceeds the soft limit. This has no negative effect if the actuator contacts the load. If the actuator misses the load, however, the soft limit will be reached and thus this message is displayed as a warning. Change either the target position or positioning band.
122	Multiple axes connected at assignment	Address was assigned when multiple axes were connected. Assign each address only when one axis is connected.
180 181 182	Address change OK Controller initialization OK Home change all clear	These messages are displayed to confirm operation. (They don't indicate an operation error or other abnormality.)

Code	Error name	Cause/Action
20C	CSTR-ON during operation	This message indicates that the start signal (CSTR) was turned ON by the PLC while the actuator was moving, and that duplicate movement commands occurred as a result.
20D	STP-OFF during operation	This message indicates that the pause signal (*STP) was turned OFF by the PLC while the actuator was moving, and that the movement was disabled as a result.
20E	Soft limit over	This message indicates that a soft limit was reached.
20F	Push & hold missed-contact detection	This message indicates that the actuator didn't contact the load during push & hold operation. Check the load condition and review the target position/positioning band settings.
210	HOME-ON during operation	This message indicates that the home return signal (HOME) was turned ON by the PLC while the actuator was moving, and that duplicate movement commands occurred as a result.
301 302 304 305 306 308 30A 30B	Overrun error (M) Flaming error (M) SCIR-QUE OV (M) SCIS-QUE OV (M) R-BF OV Response timeout (M) Packet R-QUE OV Packet S-QUE OV	These messages indicate an error in the serial communication with the controller. Cause: [1] Garbage data due to the effect of noise [2] Duplicate slave numbers when multiple controllers are controlled by serial communication Action: [1] Adjust the wiring in a manner eliminating the effect of noise and review the installation of equipment, etc. [2] Change the slave numbers to avoid duplication. If the message is still displayed after taking the above actions, please contact IAI.
307	Memory command refused	This message indicates that the command was refused in the serial communication with the controller.
309	Write address error	This message indicates that an indeterminate WRITE address error occurred in the serial communication with the controller. These conditions do not occur in normal operation. Should they occur, record the entire error list before cutting off the power for use in the cause investigation. Also contact IAI.
30C	No connected axis	This message indicates that no actuator address is recognized. Cause: [1] The controller is not operating properly. [2] Only the supplied communication cable (SGA/SGB) is disconnected. [3] If a SIO converter or insulated PIO terminal block is used, 24V is supplied to the converter but the link cable is not connected. [4] The ADRS switch settings are duplicated by mistake when multiple actuators are linked. [5] Faulty communication IC on the control board Action: [1] Check if the LED is illuminating in green. If the LED is not illuminating, the controller board is faulty. [2] If a spare teaching pendant is available, replace the current pendant with the spare unit, or with a PC, and see if the message disappears. [3] Connect the communication cable and then supply 24-V power. [4] Make sure the address settings are not duplicated. If a green LED lamp is lit and none of causes [2], [3] and [4] is present, please contact IAI.

9.5 Specific Problems

- I/O signals cannot be exchanged with the PLC.
Cause: [1] The 24-V power supply is connected in reverse.
(This will not affect the input circuits, but the output circuits may be damaged.)
[2] If the problem is with an output circuit, the fusing resistor may have blown due to a large load that caused the current flowing into the circuit to exceed the maximum current.
[3] Contact failure in the connector or relay terminal block on the PLC end.
Action: Check the connection condition of the power supply and connector, as well as the load on the output side.
If the cause is identified as [1] or [2], the controller board must be replaced. Please contact IAI.
- The LED lamp does not illuminate after the power is input.
Cause: [1] Reverse connection of the 24-V power supply
[2] Faulty controller board
If the power supply is connected properly, probably the controller board is faulty. Please contact IAI.
(Note) If the 24-V power supply is connected in reverse, the controller may not fail immediately but its service life will likely be shortened.
- The LED illuminates in red when the power is turned on.
(An alarm is present or the motor drive power is cut off.)
Check on the I/O monitor screen of the PC or teaching pendant if the alarm signal (*ALM) is output.
If the alarm signal is output, check the description of the error and remove the cause.
If alarm code 41 (motor voltage drop) is displayed, it means the motor drive power is cut off. Check the following items:
[1] Is the emergency-stop switch on the operation panel pressed? Also confirm that the necessary interlocks are released.
[2] Is the emergency-stop switch on the teaching pendant pressed?
[3] If a SIO converter is used, is the PORT switch turned ON when a teaching pendant is not connected?
- Home return ends in the middle in a vertical application.
Cause: [1] The load exceeds the rating.
[2] The ball screw is receiving torsional stress due to the affixing method of the actuator, tightening of bolts only on one side, etc.
[3] The slide resistance of the actuator itself is large.
Action: [1] Increase the value set in user parameter No. 13 (Current-limiting value during home return).
Increasing this value will cause the home return torque to increase, so do not increase the parameter setting above 75%.
[2] Loosen the fixing bolts and check if the slider moves smoothly.
If the slider moves smoothly, review the affixing method and bolt tightening condition.
[3] If the slide resistance of the actuator itself is large, please contact IAI.
- Noise occurs during downward movements in a vertical application.
Cause: The load exceeds the rating.
Action: [1] Decrease the speed.
[2] Decrease the value set in the user parameter No. 7 (Servo gain number). Do not decrease the parameter setting below "3."

- Vibration occurs when the actuator is stopped.
Cause: The slider is receiving an external force.
Action: If the external force cannot be removed, increase the value set in user parameter No. 12 (Current-limiting value at standstill during positioning).
Increasing this value will cause the holding torque at standstill to increase, so do not increase the parameter setting above 70%.
- The actuator overshoots when decelerated to a stop.
Cause: High load inertia is generated due to the combination of load capacity and deceleration.
Action: Decrease the acceleration/deceleration setting.
- The home and target positions sometimes shift on the rod-type actuator.
Cause: The current-limiting value is lower than what is required in view of the load capacity and slide resistance.
Action: The actuator may have to be replaced in some cases. Please contact IAI.
- The speed is slow during push & hold operation.
Cause: The set current-limiting value is low with respect to the load and slide resistance.
Action: Increase the current-limiting value for push & hold operation.
- The actuator operates abnormally when the servo is turned on following the power on.
Cause: The excited phase is not detected correctly when the servo is turned on because of one of the following conditions at the time of power on:
[1] The slider or rod is contacting the mechanical end.
[2] An excessive external force is exerted to the work.
Action: [1] Check if the slider or rod is contacting the mechanical end. If it is, move the slider/rod away from the mechanical end. If the actuator is equipped with a brake, move the slider/rod after releasing the brake by turning on the brake release switch. At this time, pay attention to prevent the work from falling due to its dead weight and protect your hand, robot, and the work from injuries/damages.
[2] Check if the work is in contact with an object in the surroundings. If so, move the work away from the obstruction to provide a minimum clearance of 1 mm.
If neither of causes [1] and [2] is present, please contact IAI.

10. Maintenance and Inspection

10.1 Inspection Items and Timings

Perform maintenance and inspection per the schedule specified below.

This schedule assumes eight hours of operation a day. Shorten the inspection intervals if the utilization is higher, such as when the actuator is operated continuously day and night.

	Visual inspection of appearance	Greasing	Model	
Start-up inspection	○			
After 1 month of operation	○			
After 3 months of operation	○	○ (Rod slide surface)	Rod type	*1
Every 3 months thereafter	○	○ (Rod slide surface)	Rod type	*1
After 3 years of operation or 5,000 km of moving distance	○	○ (Guide/ball screw)	Slider type	*2
Every 1 year thereafter	○	○ (Guide/ball screw)	Slider type	*2

*1 With a rod-type actuator, grease the rod slide surface if the surface is found dry at the start-up inspection or every three months.

*2 With a slider-type actuator, grease the guide and ball screw as necessary by considering the use environment, condition, etc.

10.2 Visual Inspection of Appearance

Check the following items in the visual inspection:

Actuator	Loose actuator-mounting bolts, etc.
Cables	Damage, connector coupling
Overall	Noise, vibration

10.3 Cleaning

- Clean the exterior as necessary.
- Wipe off dirt using a soft cloth, etc.
- Do not blow compressed air at high speed. Doing so may cause dust to enter the actuator through gaps.
- Do not use petroleum solvent, since it will damage the resin and coated surfaces.
- To remove significant soiling, wipe the area gently using a soft cloth, etc., moistened with neutral detergent.

10.4 Internal Check (Slider Type)

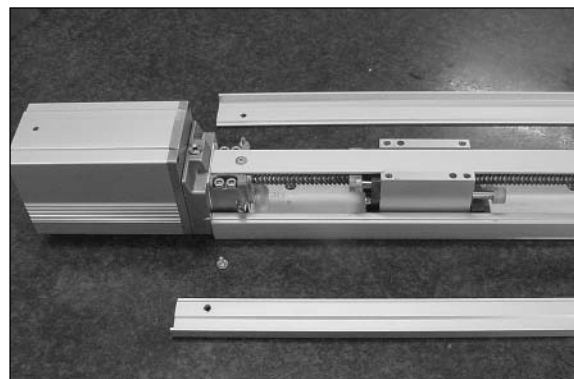
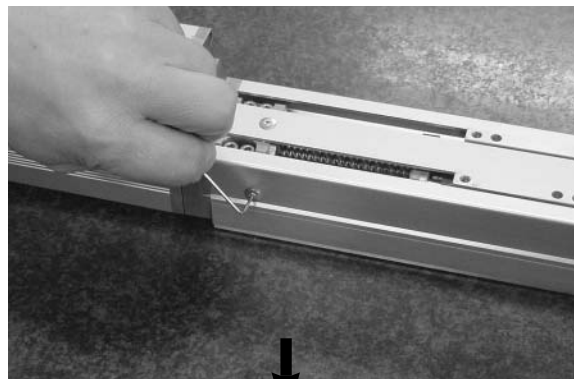

- [1] With the SA6 and SA7, the screw cover and side covers can be removed using a hex wrench with 1.5 mm width across flats.
- The front and rear brackets are supporting the ball screw, so do not disassemble these brackets.
 - Precision instrument is assembled into the motor cover, so do not disassemble the motor cover.

- [2] Visually check the internal condition. Check for intrusion of dust and other foreign object, and also check the lubrication condition. Even when the grease is brown, the sliding surface is lubricated properly if the surface looks wet and glowing.



Warning: The encoder phase is adjusted precisely to enable detection of rotation angle and home signal. Never touch the encoder, since it may cause a breakdown.

- [3] If the grease is contaminated with dust and not glowing, or if the grease has been consumed over a long period of use, apply grease after cleaning the respective parts.
- [4] When the inspection/maintenance is complete, install the side covers, stainless sheet and slider cover by reversing the procedure in step [1] above. The tightening torque should be around the level applicable for cross-recessed screws.

10.5 Internal Cleaning (Slider Type)

- Wipe off dirt using a soft cloth, etc.
- Do not blow compressed air at high speed. Doing so may cause dust to enter the actuator through gaps.
- Do not use petroleum solvent, neutral detergent or alcohol.

Note: Do not use cleaning oil, molybdenum grease or rustproof lubricant.
If a large amount of foreign object is contained in the grease, wipe off the dirty grease before applying new grease.

10.6 Greasing the Guide (Slider Type)

(1) Applicable grease

IAI uses lithium grease No. 2.

The following grease is applied to the guides prior to shipment:

Idemitsu Kosan	Daphne Eponex Grease No. 2
----------------	----------------------------

Equivalent grease products are available from other companies. For details, contact each manufacturer and ask for a product equivalent to the aforementioned brand. Equivalence of the following products has been confirmed:

Showa Shell Sekiyu	Albania Grease S2
Exxon Mobil	UNIREX N2

(2) Greasing method

Grease the guide by following the procedure below:

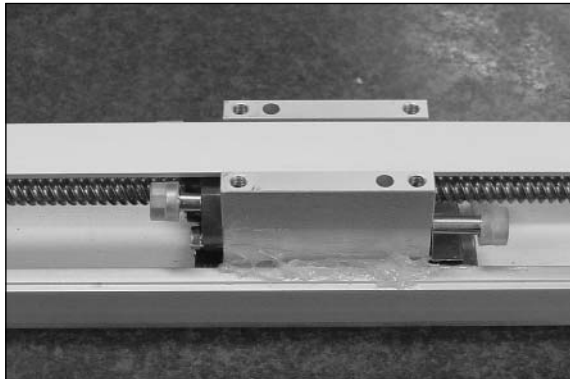

- [1] Apply grease between the slider and base, as shown to the left.
Apply grease on the opposite side in the same manner.

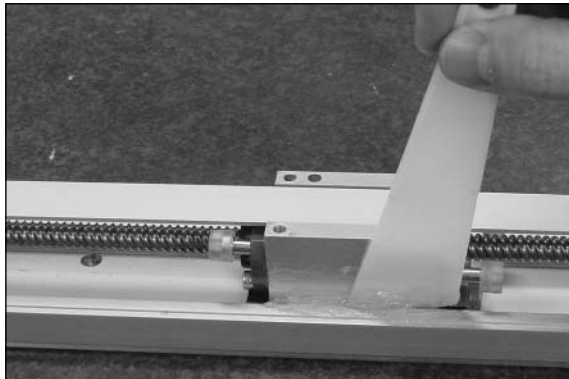

- [2] Spread the grease evenly between the slider and base using a spatula, as shown to the left.
Spread the grease evenly on the opposite side in the same manner.

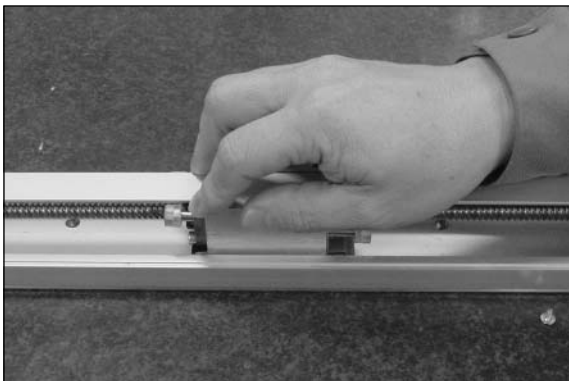

- [3] Move the slider back and forth several times by hand.
- [4] Repeat steps [1], [2] and [3].
- [5] Use a waste cloth, etc., to wipe off excess grease from the slider.

10.7 Greasing the Ball Screw (Slider Type)

(1) Applicable grease

The following special grease is applied to the ball screw prior to shipment:

Kyodo Yushi	Multemp LRL3
-------------	--------------

This grease generates less heat and has other excellent properties suitable for ball screws. For equivalent grease products, refer to the brands specified for the guide (lithium grease).

! Note to the user: Never use fluorine grease. If fluorine grease is mixed with lithium grease, the grease function will drop and it causes damage to the mechanism.

(2) Greasing method

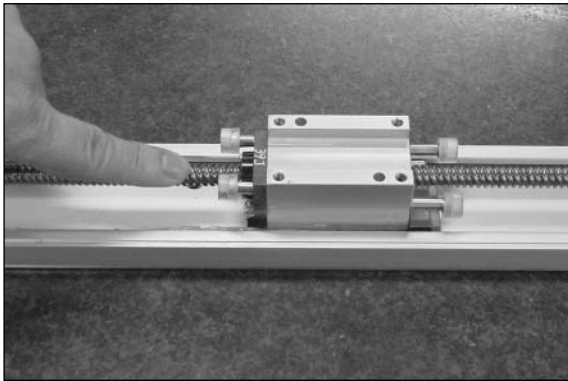

After cleaning the ball screw, apply grease and stroke the slider to let the grease spread evenly. As the final step, wipe off excess grease from the ball screw. This is because excessive grease will cause the agitation resistance to increase and allow the ball screw to generate heat easily. Wiping off excess grease will also prevent extra grease on the ball screw from flying off and staining the surrounding area as the screw turns.

* With the ERC, the speed will vary depending on the load. Be careful not to grease the ball screw excessively.

10.8 Greasing the Rod Slide Surface

(1) Applicable grease

The following grease is applied to the rod slide surface prior to shipment:

Kyodo Yushi	Multemp LRL3
-------------	--------------

Use lithium grease for maintenance.

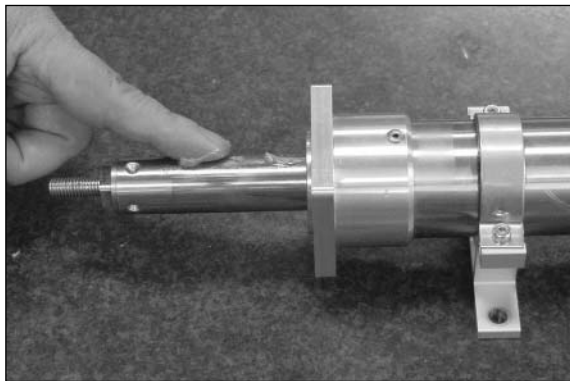

! Note to the user: Never use fluorine grease. If fluorine grease is mixed with lithium grease, the grease function will drop and it causes damage to the mechanism.

10.9 Motor Replacement Procedure

Before replacing the motor, save the latest parameter and position data.

Save the data by one of the following methods:

- Save the data to a file using the PC software.
- Prepare position/parameter tables and manually write the values.

When a new motor has been installed, enter the parameter/position data to the controller.

Follow the procedure below to replace the motor unit or coupling spacer:

- Removal

- [1] Remove the coupling bolt from the rear bracket using a wrench with 3 mm width across flats.
- [2] Hold the motor cover and pull backward to remove the motor unit. (Exercise caution to prevent pinching of parts.)

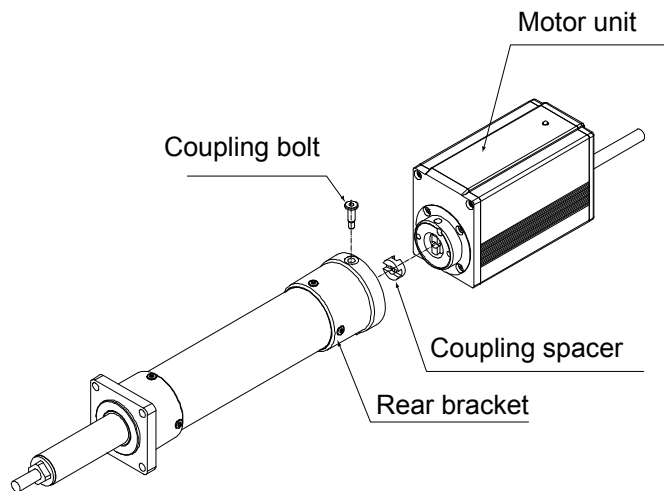
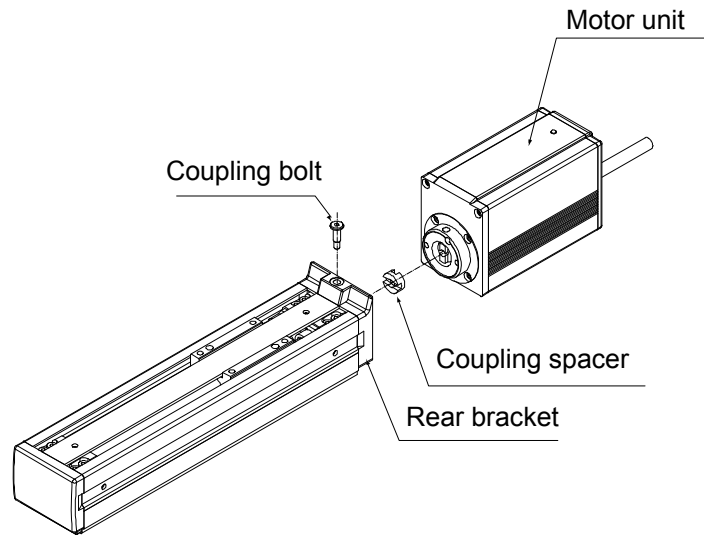

- Installation

- [1] Place the coupling spacer in the coupling hub.
- [2] Insert the motor unit into the rear bracket while paying attention to the phase of the coupling hub with respect to the coupling spacer. (When inserting the motor unit, exercise due caution to prevent pinching of parts.)
- [3] Insert the coupling bolt into the fitting hole in the motor unit from over the rear bracket, and tighten the bolt using a wrench with 3 mm width across flats.

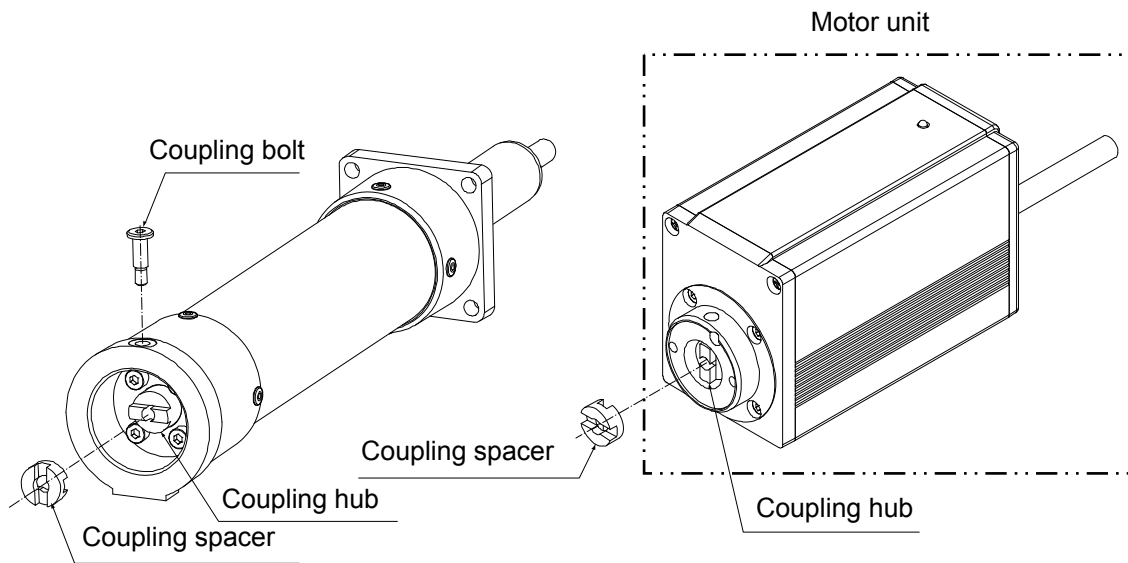

* Appendix

Example of Basic ERC Positioning Sequence

Given below is an example of basic sequence for creating a positioning sequence using the ERC.

■ indicates PIO signals of the ERC controller.

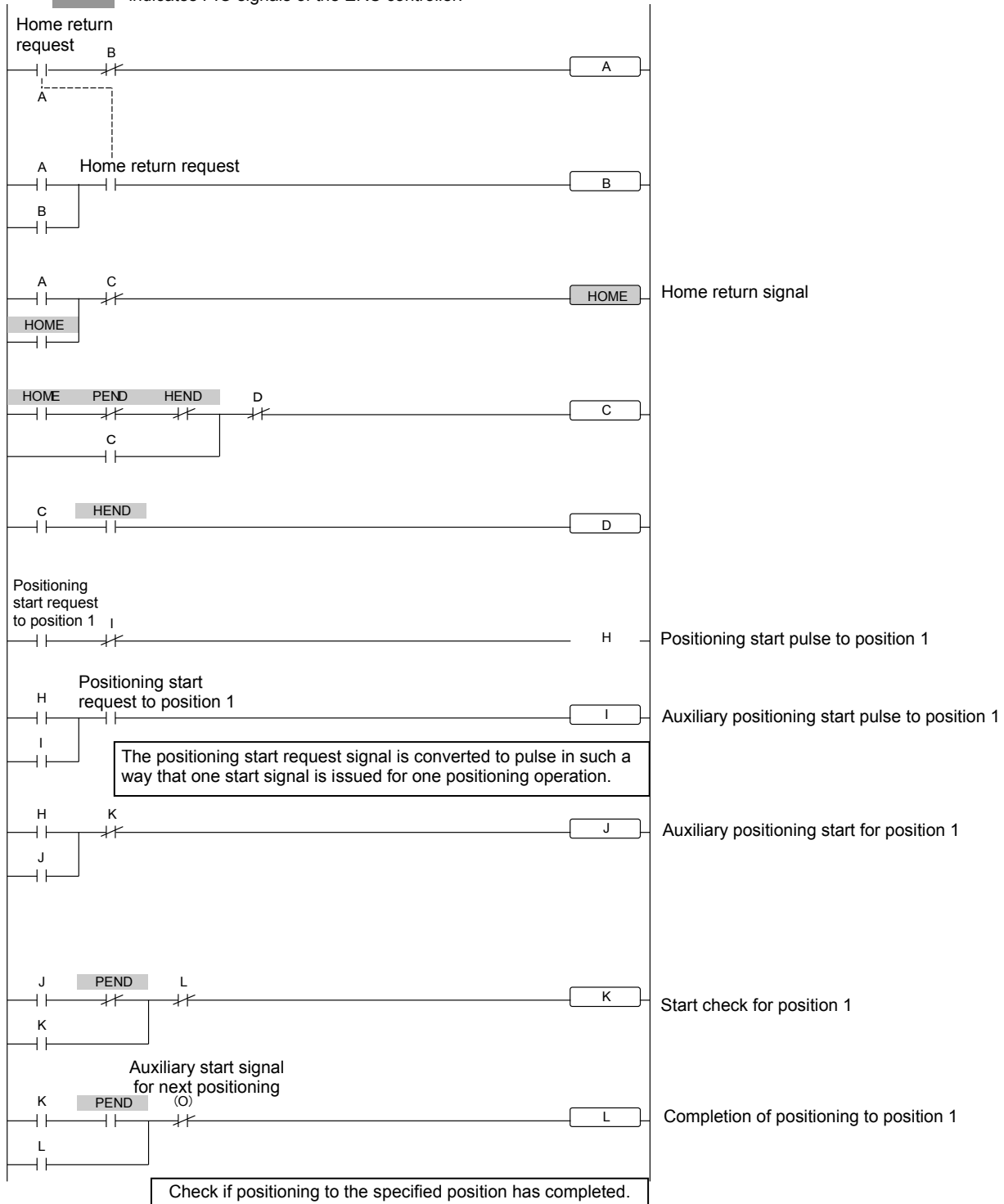

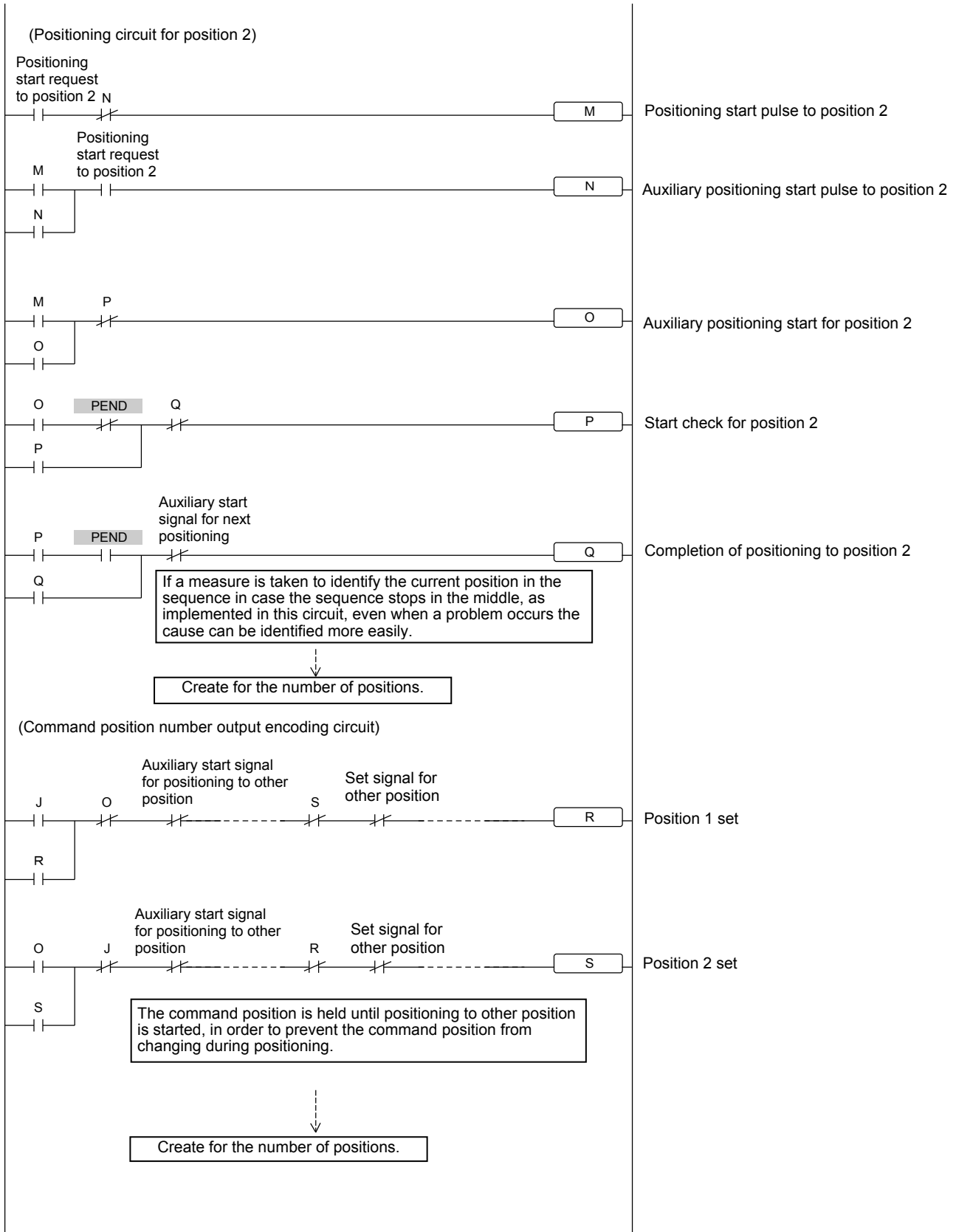

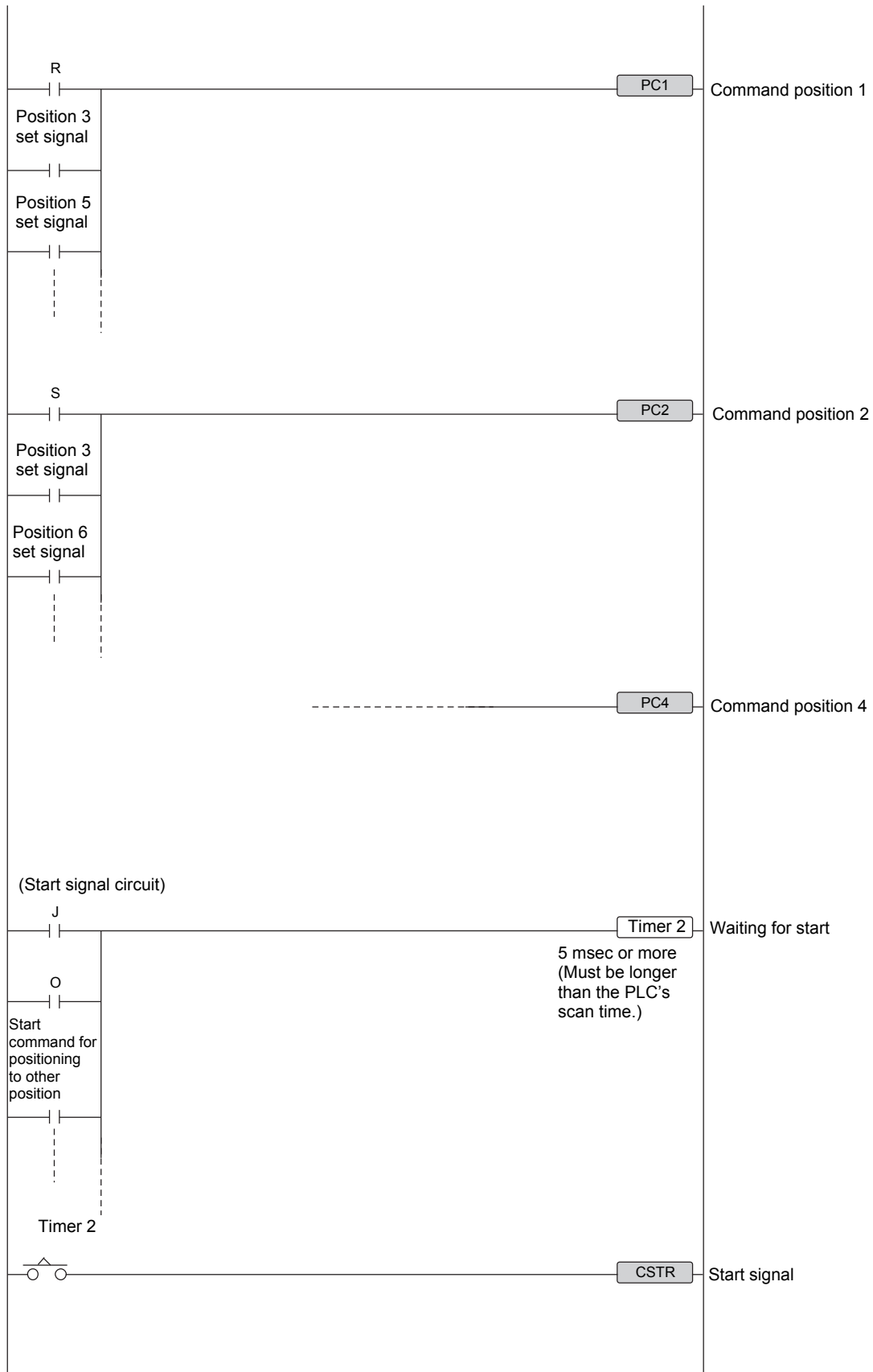

Recording of Position-Data Table

Recorded date: _____

No.	Position [mm]	Speed [mm/sec]	Acceleration/ deceleration [G]	Push [%]	Positioning band [mm]	Acceleration only MAX
0						
1						
2						
3						
4						
5						
6						
7						
8						
9						
10						
11						
12						
13						
14						
15						

Parameter Records

Recorded date: _____

- Category a: Parameter relating to the actuator stroke range
 b: Parameter relating to the actuator operating characteristics
 c: Parameter relating to the external interface
 d: Servo gain adjustment

No.	Category	Name	Unit	Recorded data
1	a	Zone boundary 1+	mm	
2	a	Zone boundary 1-	mm	
3	a	Soft limit+	mm	
4	a	Soft limit-	mm	
5	a	Home return direction (0: [Reverse]/1: [Forward])	-	
6	b	Push & hold stop judgment period	msec	
7	d	Servo gain number	-	
8	b	Default speed	mm/sec	
9	b	Default acceleration/deceleration	G	
10	b	Default positioning band (in-position)	mm	
11	b	Default acceleration only MAX flag	-	
12	b	Current-limiting value at standstill during positioning	%	
13	b	Current-limiting value during home return	%	
14		(Reserved for future extension)		
15	c	Pause input disable selection (0: [Enable]/1: [Disable])	-	
16	c	Serial communication speed	bps	
17	c	Minimum delay time for slave transmitter activation	msec	
18		(Reserved for future extension)		
19		(Reserved for future extension)		
20		(Reserved for future extension)		
21		(Reserved for future extension)		
22	a	Home return offset	mm	
23		(Reserved for future extension)		
24		(Reserved for future extension)		
25	c	PIO pattern selection	-	
26		(Reserved for future extension)		
27	c	Movement command type (0: [Level]/1: [Edge])	-	
28	b	Excited-phase signal detection direction [0: Reverse / 1: Forward]	-	

RC ROBO CYLINDER

Change History

Revision Date	Description of Revision
January 2011	<p>Seventh edition</p> <ul style="list-style-type: none">• Added "Before Use."• Changed "Safety Precautions" to "Safety Guide."• P. 6: Added 1.3.3, "Sound Pressure Levels of This Product Will Not Exceed 70 dB."• P. 14: Moved "Prohibited Handling of Cables" to after 1.8, "Cabling."
June 2015	<p>7C edition</p> <ul style="list-style-type: none">• P. 15: Change made in caution note for connection to controller• P. 120: Grease change due to production stop<ul style="list-style-type: none">Albania Grease No.2 → Albania Grease S2Mobilax 2 → UNIREX N2



IAI Corporation

Head Office: 577-1 Obane Shimizu-KU Shizuoka City Shizuoka 424-0103, Japan
TEL +81-54-364-5105 FAX +81-54-364-2589
website: www.iai-robot.co.jp/

Technical Support available in USA, Europe and China

IAI America, Inc.

Head Office: 2690 W. 237th Street, Torrance, CA 90505
TEL (310) 891-6015 FAX (310) 891-0815
Chicago Office: 110 East State Parkway, Schaumburg, IL 60173
TEL (847) 908-1400 FAX (847) 908-1399
Atlanta Office: 1220 Kennestone Circle, Suite 108, Marietta, GA 30066
TEL (678) 354-9470 FAX (678) 354-9471
website: www.intelligentactuator.com

IAI Industrieroboter GmbH

Ober der Röth 4, D-65824 Schwalbach am Taunus, Germany
TEL 06196-88950 FAX 06196-889524

IAI (Shanghai) Co., Ltd.

SHANGHAI JIAHUA BUSINESS CENTER A8-303, 808, Hongqiao Rd. Shanghai 200030, China
TEL 021-6448-4753 FAX 021-6448-3992
website: www.iai-robot.com

IAI Robot (Thailand) Co., Ltd.

825 PhairojKijja Tower 12th Floor, Bangna-Trad RD., Bangna, Bangkok 10260, Thailand
TEL +66-2-361-4458 FAX +66-2-361-4456