

ERC2

Actuator with Integrated
Controller (PIO Type)

Operation Manual Fifth Edition

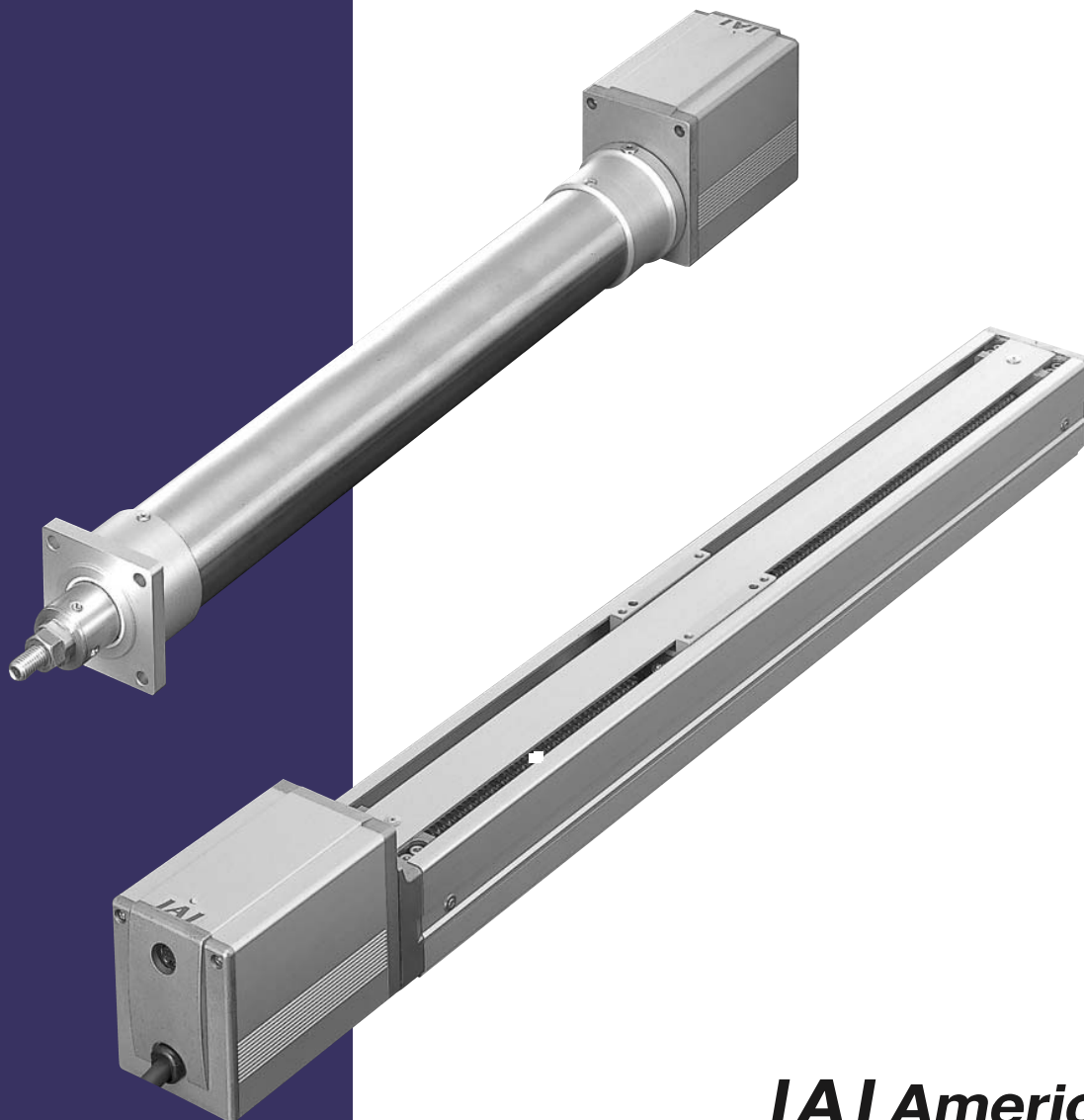

IAI America, Inc.

Please Read Before Use

Thank you for purchasing our product.

This Operation Manual explains the handling methods, structure and maintenance of this product, among others, providing the information you need to know to use the product safely.

Before using the product, be sure to read this manual and fully understand the contents explained herein to ensure safe use of the product.

The DVD that comes with the product contains operation manuals for IAI products.

When using the product, refer to the necessary portions of the applicable operation manual by printing them out or displaying them on a PC.

After reading the Operation Manual, keep it in a convenient place so that whoever is handling this product can reference it quickly when necessary.

[Important]

- This Operation Manual is original.
- The product cannot be operated in any way unless expressly specified in this Operation Manual. IAI shall assume no responsibility for the outcome of any operation not specified herein.
- Information contained in this Operation Manual is subject to change without notice for the purpose of product improvement.
- If you have any question or comment regarding the content of this manual, please contact the IAI sales office near you.
- Using or copying all or part of this Operation Manual without permission is prohibited.
- The company names, names of products and trademarks of each company shown in the sentences are registered trademarks.

1. Using Multiple 24-V Power Supplies

If multiple 24-V power supplies are used, always connect the 0-V lines of all power supplies. If not, damage to the controller board, SIO converter or other components may occur.

[Connection Example]

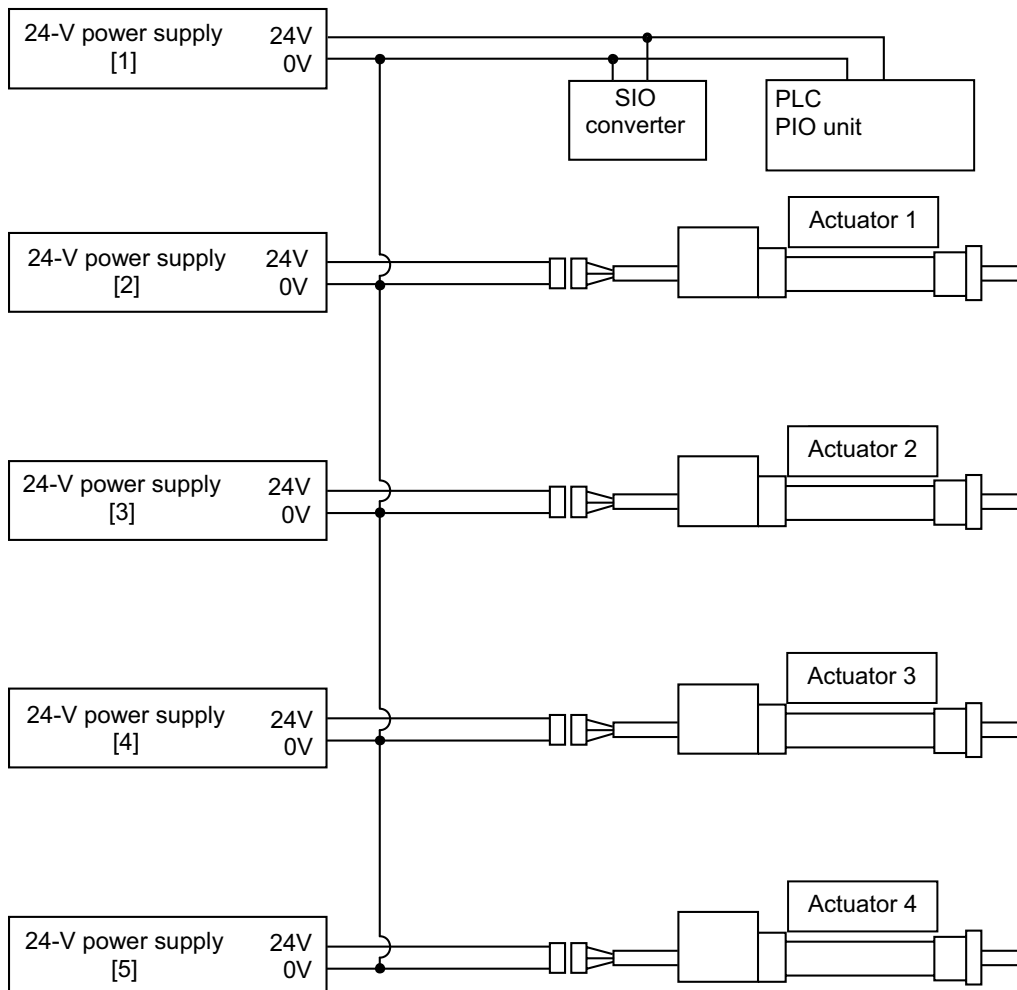

2. Basic Parameter Settings

When the power is turned on for the first time, at least the two parameters explained below must be set in accordance with your specific application.

Remember to always set these parameters properly, because improper settings will prevent the product from operating correctly.

For details on how to set these parameters, refer to “parameter settings” of the PC software or teaching pendant.

[1] Selecting a PIO pattern

This controller provides four PIO patterns to support various applications.

To select a desired pattern, set the corresponding number between 0 and 3 in parameter No. 25 (PIO pattern selection).

The factory setting is “0.”

Setting of parameter No. 25	Features of PIO pattern
0	8 points The basic pattern providing eight positioning points.
1	3 points (air cylinder) This pattern assumes that the actuator is used in place of an air cylinder. The number of positioning points is limited to three, but a direct command input and a position complete output are provided separately for each target position in line with the conventional practice of air cylinder control. This lets you control the actuator just like an air cylinder.
2	16 points (setting by zone boundary parameters) The number of positioning points is increased to 16. The boundaries defining the output range of the zone signal are set by parameters.
3	16 points (setting in zone fields in the position table) The number of positioning points is increased to 16. The boundaries defining the output range of the zone signal can be set differently for each position in the position table. Accordingly, this pattern is ideal for applications where the setup is changed from time to time.

[2] Enabling/disabling the pause signal (*STP)

The pause signal is provided as a contact-b signal to enable fail-safe action.

Therefore, this signal must remain ON during normal conditions of use.

Since there are applications where this signal is not necessary, however, a parameter is provided to enable/disable the signal so that you need not turn ON the signal every time.

To enable or disable the pause signal, set “0” or “1” in user parameter No. 15 (Pause input disable selection).

	Setting
Enable (Use)	0
Disable (Do not use)	1

The factory setting is “0: [Enable].”

3. PC Software and Teaching Pendant Models

This product offers new functions not available in the conventional ERC series.

To support these new functions, the communication protocol has been changed to a general Modbus-compliant protocol. Accordingly, the PC software programs and teaching pendants that have been used with the ERC series are no longer compatible with the ERC2 series.

Select a compatible program or teaching pendant from among the model numbers listed below.

	Model number	Remarks
PC software (with RS232C communication cable)	RCM-101-MW	These software programs/teaching pendants can be used with the ERC series.
PC software (with USB communication cable)	RCM-101-USB	
Teaching pendant	RCM-T	
Simple teaching pendant	RCM-E	
Data setting unit	RCM-P	

4. Backup of Latest Data

The built-in controller of this actuator uses a nonvolatile memory to store position table data and parameters. Normally data is retained after the power has been cut off, but stored data will be lost if the nonvolatile memory is damaged.

Regular backup of latest position table data and parameters not only ensures that your important data is safeguarded, but it also saves the data recovery time when a need arises to replace the controller board for some reason.

To back up your data, do one of the following:

[1] Save the data to a CD or FD from the PC software.

[2] Create a position table sheet or parameter sheet and write down the settings.

5. Plugging/Unplugging ERC2PIO Teaching Tools

- [1] When plugging or unplugging a teaching tool (PC software/teaching pendant) connector, make sure the power is turned off. If the connector is plugged or unplugged while the power is on, internal circuits may be damaged.

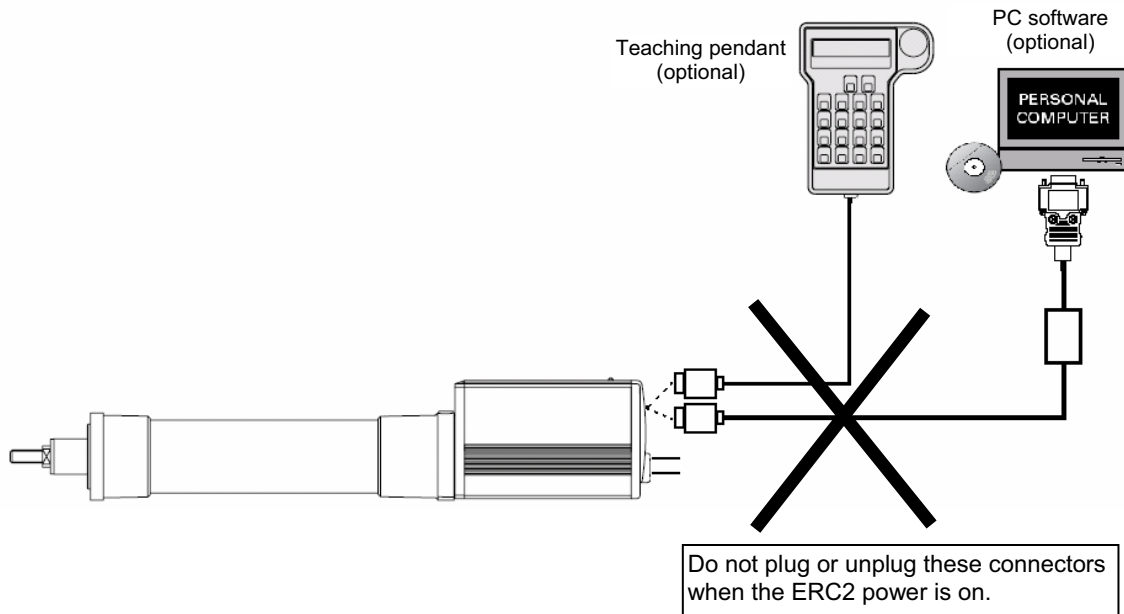

- [2] Install a diode in parallel with the relay coil shown in the circuit diagram below, or use a relay coil with built-in diode. If there is no diode, internal circuits may be damaged.

* To eliminate noise, install noise killers (or diodes in the case of DC circuit) for the coils of all relays, solenoid valves, etc. This is also mentioned in the operation manual.

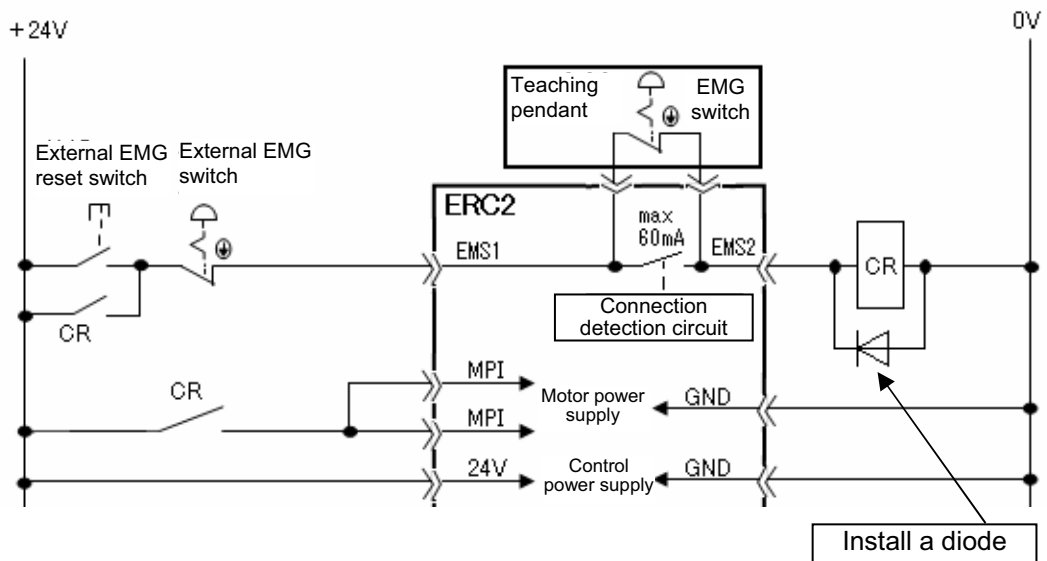

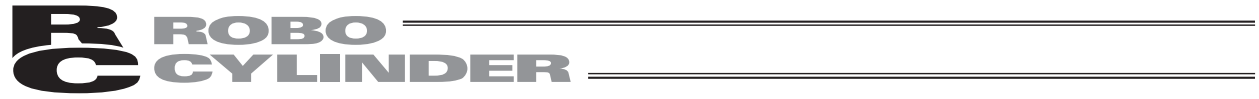

CE Marking

If a compliance with the CE Marking is required, please follow Overseas Standards Compliance Manual (ME0287) that is provided separately.

Table of Contents

Safety Guide.....	1
1. Overview	9
1.1 Introduction	9
1.2 Meaning of the Model Number.....	10
1.3 Specifications.....	11
1.3.1 Correlation Diagrams of Speed and Payload Capacity – Slider Type	12
1.3.2 Correlation Diagrams of Speed and Payload Capacity – Rod Type.....	13
1.3.3 The sound pressure level of this product does not exceed 70 dB.....	14
1.4 Warranty.....	15
1.5 Transportation and Handling.....	17
1.5.1 Handling before Unpacking.....	17
1.5.2 Handling after Unpacking.....	17
1.6 Installation Environment and Noise Elimination	18
1.6.1 Installation Environment.....	18
1.6.2 Storage Environment	18
1.6.3 Power Supply.....	19
1.6.4 Noise Elimination	19
1.7 Cabling.....	21
2. Installation	24
2.1 Name of Each Part.....	24
2.1.1 Slider Type (SA6C/SA7C).....	24
2.1.2 Rod Type (RA6C/RA7C).....	24
2.1.3 (1) Rod Type with a Single Guide (RGS6C/RGS7C)	25
(2) Rod Type with Double Guides (RGD6C/RGD7C).....	25
2.2 Installation.....	26
2.2.1 Slider Type.....	26
● Installing the actuator	26
2.2.2 Rod Type	27
● Affixing with a flange	27
● Affixing through holes in a flange	27
● Affixing with foot brackets (optional).....	28
2.2.3 Installing the Load.....	29
● Slider Type.....	29
● Rod Type.....	30
● Rod type with a guide(s)	30
3. Wiring	31
3.1 Basic Structure.....	31
3.2 Configuration Using a SIO Converter.....	34
3.2.1 Example of Connecting Multiple Axes Using Link Cables	37
3.2.2 Address Assignment	38
3.3 Configuration Using an Isolated PIO Terminal Block.....	39
3.4 Configuration Using Both SIO Converter and Isolated PIO Terminal Block	42
3.4.1 Example of Connecting Multiple Axes Using Link Cables	45
3.4.2 Address Assignment	46
3.5 Specifications of I/O Signals	47
3.5.1 Recognition of Input Signals	47
3.5.2 External Input Specifications.....	48
3.5.3 External Output Specifications	49
3.6 I/O Signals for PIO Pattern 1 [3 Points] (Air Cylinder).....	50
3.6.1 Explanation of I/O Signals.....	50
3.6.2 Details of Input Signals	51

■	Movement to each position (ST0 to ST2).....	51
■	Pause (*STP).....	51
■	Alarm reset (RES).....	51
3.6.3	Details of Output Signals.....	52
■	Completion of each position (PE0 to PE2).....	52
■	Alarm (*ALM).....	52
3.7	I/O Signals for PIO Pattern 0 [8 Points].....	53
3.7.1	Explanation of I/O Signals.....	53
3.7.2	Details of Input Signals.....	54
■	Start (CSTR).....	54
■	Command position number (PC1 to PC4).....	54
■	Pause (*STP).....	54
■	Home return (HOME).....	54
3.7.3	Details of Output Signals.....	55
■	Position complete (PEND).....	55
■	Home return completion (HEND).....	55
■	Zone (ZONE).....	55
■	Alarm (*ALM).....	55
3.8	I/O Signals for PIO Pattern 2 [16 Points] (Setting by Zone Boundary Parameters).....	57
3.8.1	Explanation of I/O Signals.....	57
3.8.2	Details of Input Signals.....	58
■	Start (CSTR).....	58
■	Command position number (PC1 to PC8).....	58
■	Pause (*STP).....	58
3.8.3	Details of Output Signals.....	59
■	Position complete (PEND).....	59
■	Home return completion (HEND).....	59
■	Zone (ZONE).....	59
■	Alarm (*ALM).....	59
3.9	I/O Signals for PIO Pattern 3 [16 Points] (Setting in Zone Fields in the Position Table).....	61
3.9.1	Explanation of I/O Signals.....	61
3.9.2	Details of Input Signals.....	62
■	Start (CSTR).....	62
■	Command position number (PC1 to PC8).....	62
■	Pause (*STP).....	62
3.9.3	Details of Output Signals.....	63
■	Position complete (PEND).....	63
■	Home return completion (HEND).....	63
■	Zone (PZONE).....	63
■	Alarm (*ALM).....	63
3.10	Emergency-Stop Circuit.....	65
3.11	Extension Cable.....	67
4.	Electrical Specifications.....	69
4.1	Controller.....	69
4.2	SIO Converter (Optional).....	70
4.3	Isolated PIO Terminal Block (Optional).....	72
5.	Data Entry <Basic>.....	78
5.1	Description of Position Table.....	78
5.1.1	Relationship of Push Force at Standstill and Current-Limiting Value.....	83
●	Slider type.....	83
(1) SA6C type (2) SA7C type.....	83	
●	Rod type.....	84
(1) RA6C type (2) RA7C type.....	84	
5.2	Explanation of Functions.....	85
5.2.1	Positioning Mode Push = 0.....	85
5.2.2	Push & Hold Mode Push = Other than 0.....	85
5.2.3	Speed Change during Movement.....	87
5.2.4	Operation at Different Acceleration and Deceleration Settings.....	87
5.2.5	Pause.....	88

5.2.6	Zone Signal Output.....	88
5.2.7	Home Return	89
5.3	Power-saving Modes at Standby Positions	90
6.	Operation in the “3 Points (Air Cylinder)” Mode <Practical Operation>	93
6.1	Overview of the “3 Points” Mode.....	93
6.2	How to Start	95
6.3	Position Table and Parameter Settings Required for Operation.....	97
6.3.1	Test Operation	97
	Safety speed during manual feed	97
	Speed override for movement commands from the PLC	97
6.3.2	Full-scale Operation.....	98
	Saving energy when the actuator stands by for a long time after the power has been turned on ..	98
	Saving energy when the actuator stands by for a long time at the target position	98
	Output mode of position complete signal	98
6.4	Moving Operation	99
7.	Operation in the “8 Points” and “16 Points” Modes <Practical Operation>	103
7.1	How to Start	103
7.2	Position Table and Parameter Settings Required for Operation.....	105
7.2.1	Test Operation	105
	Safety speed during manual feed	105
	Speed override for movement commands from the PLC	105
7.2.2	Full-scale Operation.....	106
	Saving energy when the actuator stands by for a long time after the power has been turned on	106
	Power saving when the actuator stands by for a long time after the home return effected by the	106
	HOME input signal	106
	Saving energy when the actuator stands by for a long time at the target position	106
	Output mode of position complete signal	106
7.3	How to Execute Home Return	107
7.3.1	8 Points.....	107
7.3.2	16 Points.....	108
7.4	Home Return and Movement after Start (16 Points)	109
7.5	Positioning Mode (Back and Forth Movement between Two Points)	111
7.6	Push & Hold Mode.....	113
7.6.1	Notes on Returning in the Incremental Mode after Push & Hold Operation	115
	● Positioning mode.....	115
	● Push & hold mode.....	115
7.7	Speed Change during Movement	116
7.8	Operation at Different Acceleration and Deceleration Settings	118
7.9	Pause.....	120
7.10	Zone Signal.....	122
7.11	Incremental Moves.....	124
7.11.1	How to Determine the Final Position.....	126
7.12	Notes on Incremental Mode.....	127
8.	Parameter Settings.....	130
8.1	Parameter Table.....	130
8.2	Detailed Explanation of Parameters.....	131
8.2.1	Parameters Relating to the Actuator Stroke Range	131
	● Soft limit	131
	● Home return direction.....	131
	● Home return offset	132
	● Zone boundary	132
8.2.2	Parameters Relating to the Actuator Operating Characteristics	133
	● Default speed	133
	● Default acceleration/deceleration	133
	● Default positioning band (in-position)	133
	● Current-limiting value during home return	133
	● Current-limiting value at standstill during positioning	133
	● Speed override.....	133

●	Default direction of excited-phase signal detection	134
●	Excited-phase signal detection time	134
●	Safety speed	134
●	Automatic servo-off delay time	135
●	Default standstill mode	135
●	Push speed	136
●	Push & hold stop judgment period	136
8.2.3	Parameters Relating to the External Interface	137
●	PIO pattern selection	137
●	Movement command type	137
●	Pause input disable selection	138
●	Home-return input disable selection	138
●	Output mode of position complete signal	139
●	SIO communication speed	139
●	Minimum delay for slave transmitter activation	139
●	Silent interval multiplication factor	140
8.2.4	Servo Gain Adjustment	141
●	Servo gain number	141
●	Speed loop proportional gain	141
●	Speed loop integral gain	142
●	Torque filter time constant	142
9.	Troubleshooting	143
9.1	Action to Be Taken upon Occurrence of Problem	143
9.2	Alarm Level Classification	144
9.2.1	How to Reset Alarms	144
9.3	Alarm Description and Cause/Action	145
(1)	Operation-cancellation level alarms	145
(2)	Cold-start level alarms	147
9.4	Messages Displayed during Operation Using the Teaching Pendant	149
9.5	Specific Problems	151
●	I/O signals cannot be exchanged with the PLC	151
●	The LED lamp does not illuminate after the power is input.	151
●	The LED illuminates in red when the power is turned on.	151
●	Home return ends in the middle in a vertical application.	151
●	Noise occurs during downward movements in a vertical application	152
●	Vibration occurs when the actuator is stopped	152
●	The actuator overshoots when decelerated to a stop	152
●	The home and target positions sometimes shift on the rod-type actuator.	152
●	The speed is slow during push & hold operation	152
●	The actuator moves only a half, or as much as twice, the specified travel	152
●	The actuator operates abnormally when the servo is turned on following the power on.	152
●	The LED (green) blinks	152
10.	Maintenance and Inspection	153
10.1	Inspection Items and Schedule	153
10.2	Visual Inspection of Appearance	153
10.3	Cleaning	153
10.4	Internal Check (Slider Type)	154
10.5	Internal Cleaning (Slider Type)	155
10.6	Greasing the Guide (Slider Type)	155
10.7	Greasing the Ball Screw (Slider Type)	157
10.8	Greasing the Rod Slide Surface	158
10.9	Motor Replacement Procedure	159
11.	Appendix	161
11.1	External Dimensions	161
11.1.1	ERC2-SA6C	161
11.1.2	ERC2-SA7C	162

11.1.3	ERC2-RA6C	163
11.1.4	ERC2-RA7C	164
11.1.5	ERC2-RGS6C	165
11.1.6	ERC2-RGS7C	165
11.1.7	ERC2-RGD6C	166
11.1.8	ERC2-RGD7C	166
11.2	Example of Basic ERC2 Positioning Sequence	167
11.3	Recording of Position Table	170
11.4	Parameter Records.....	171
Change History		172

RC ROBO CYLINDER

Safety Guide

“Safety Guide” has been written to use the machine safely and so prevent personal injury or property damage beforehand. Make sure to read it before the operation of this product.

Safety Precautions for Our Products

The common safety precautions for the use of any of our robots in each operation.

No.	Operation Description	Description
1	Model Selection	<ul style="list-style-type: none"> ● This product has not been planned and designed for the application where high level of safety is required, so the guarantee of the protection of human life is impossible. Accordingly, do not use it in any of the following applications. <ol style="list-style-type: none"> 1) Medical equipment used to maintain, control or otherwise affect human life or physical health. 2) Mechanisms and machinery designed for the purpose of moving or transporting people (For vehicle, railway facility or air navigation facility) 3) Important safety parts of machinery (Safety device, etc.) ● Do not use the product outside the specifications. Failure to do so may considerably shorten the life of the product. ● Do not use it in any of the following environments. <ol style="list-style-type: none"> 1) Location where there is any inflammable gas, inflammable object or explosive 2) Place with potential exposure to radiation 3) Location with the ambient temperature or relative humidity exceeding the specification range 4) Location where radiant heat is added from direct sunlight or other large heat source 5) Location where condensation occurs due to abrupt temperature changes 6) Location where there is any corrosive gas (sulfuric acid or hydrochloric acid) 7) Location exposed to significant amount of dust, salt or iron powder 8) Location subject to direct vibration or impact ● For an actuator used in vertical orientation, select a model which is equipped with a brake. If selecting a model with no brake, the moving part may drop when the power is turned OFF and may cause an accident such as an injury or damage on the work piece.

No.	Operation Description	Description
2	Transportation	<ul style="list-style-type: none"> ● When carrying a heavy object, do the work with two or more persons or utilize equipment such as crane. ● When the work is carried out with 2 or more persons, make it clear who is to be the leader and who to be the follower(s) and communicate well with each other to ensure the safety of the workers. ● When in transportation, consider well about the positions to hold, weight and weight balance and pay special attention to the carried object so it would not get hit or dropped. ● Transport it using an appropriate transportation measure. The actuators available for transportation with a crane have eyebolts attached or there are tapped holes to attach bolts. Follow the instructions in the instruction manual for each model. ● Do not step or sit on the package. ● Do not put any heavy thing that can deform the package, on it. ● When using a crane capable of 1t or more of weight, have an operator who has qualifications for crane operation and sling work. ● When using a crane or equivalent equipments, make sure not to hang a load that weighs more than the equipment's capability limit. ● Use a hook that is suitable for the load. Consider the safety factor of the hook in such factors as shear strength. ● Do not get on the load that is hung on a crane. ● Do not leave a load hung up with a crane. ● Do not stand under the load that is hung up with a crane.
3	Storage and Preservation	<ul style="list-style-type: none"> ● The storage and preservation environment conforms to the installation environment. However, especially give consideration to the prevention of condensation. ● Store the products with a consideration not to fall them over or drop due to an act of God such as earthquake.
4	Installation and Start	<p>(1) Installation of Robot Main Body and Controller, etc.</p> <ul style="list-style-type: none"> ● Make sure to securely hold and fix the product (including the work part). A fall, drop or abnormal motion of the product may cause a damage or injury. Also, be equipped for a fall-over or drop due to an act of God such as earthquake. ● Do not get on or put anything on the product. Failure to do so may cause an accidental fall, injury or damage to the product due to a drop of anything, malfunction of the product, performance degradation, or shortening of its life. ● When using the product in any of the places specified below, provide a sufficient shield. <ol style="list-style-type: none"> 1) Location where electric noise is generated 2) Location where high electrical or magnetic field is present 3) Location with the mains or power lines passing nearby 4) Location where the product may come in contact with water, oil or chemical droplets

No.	Operation Description	Description
4	Installation and Start	<p>(2) Cable Wiring</p> <ul style="list-style-type: none"> ● Use our company's genuine cables for connecting between the actuator and controller, and for the teaching tool. ● Do not scratch on the cable. Do not bend it forcibly. Do not pull it. Do not coil it around. Do not insert it. Do not put any heavy thing on it. Failure to do so may cause a fire, electric shock or malfunction due to leakage or continuity error. ● Perform the wiring for the product, after turning OFF the power to the unit, so that there is no wiring error. ● When the direct current power (+24V) is connected, take the great care of the directions of positive and negative poles. If the connection direction is not correct, it might cause a fire, product breakdown or malfunction. ● Connect the cable connector securely so that there is no disconnection or looseness. Failure to do so may cause a fire, electric shock or malfunction of the product. ● Never cut and/or reconnect the cables supplied with the product for the purpose of extending or shortening the cable length. Failure to do so may cause the product to malfunction or cause fire. <p>(3) Grounding</p> <ul style="list-style-type: none"> ● The grounding operation should be performed to prevent an electric shock or electrostatic charge, enhance the noise-resistance ability and control the unnecessary electromagnetic radiation. ● For the ground terminal on the AC power cable of the controller and the grounding plate in the control panel, make sure to use a twisted pair cable with wire thickness 0.5mm² (AWG20 or equivalent) or more for grounding work. For security grounding, it is necessary to select an appropriate wire thickness suitable for the load. Perform wiring that satisfies the specifications (electrical equipment technical standards). ● Perform Class D Grounding (former Class 3 Grounding with ground resistance 100Ω or below).





No.	Operation Description	Description
4	Installation and Start	<p>(4) Safety Measures</p> <ul style="list-style-type: none"> ● When the work is carried out with 2 or more persons, make it clear who is to be the leader and who to be the follower(s) and communicate well with each other to ensure the safety of the workers. ● When the product is under operation or in the ready mode, take the safety measures (such as the installation of safety and protection fence) so that nobody can enter the area within the robot's movable range. When the robot under operation is touched, it may result in death or serious injury. ● Make sure to install the emergency stop circuit so that the unit can be stopped immediately in an emergency during the unit operation. ● Take the safety measure not to start up the unit only with the power turning ON. Failure to do so may start up the machine suddenly and cause an injury or damage to the product. ● Take the safety measure not to start up the machine only with the emergency stop cancellation or recovery after the power failure. Failure to do so may result in an electric shock or injury due to unexpected power input. ● When the installation or adjustment operation is to be performed, give clear warnings such as "Under Operation; Do not turn ON the power!" etc. Sudden power input may cause an electric shock or injury. ● Take the measure so that the work part is not dropped in power failure or emergency stop. ● Wear protection gloves, goggle or safety shoes, as necessary, to secure safety. ● Do not insert a finger or object in the openings in the product. Failure to do so may cause an injury, electric shock, damage to the product or fire. ● When releasing the brake on a vertically oriented actuator, exercise precaution not to pinch your hand or damage the work parts with the actuator dropped by gravity.
5	Teaching	<ul style="list-style-type: none"> ● When the work is carried out with 2 or more persons, make it clear who is to be the leader and who to be the follower(s) and communicate well with each other to ensure the safety of the workers. ● Perform the teaching operation from outside the safety protection fence, if possible. In the case that the operation is to be performed unavoidably inside the safety protection fence, prepare the "Stipulations for the Operation" and make sure that all the workers acknowledge and understand them well. ● When the operation is to be performed inside the safety protection fence, the worker should have an emergency stop switch at hand with him so that the unit can be stopped any time in an emergency. ● When the operation is to be performed inside the safety protection fence, in addition to the workers, arrange a watchman so that the machine can be stopped any time in an emergency. Also, keep watch on the operation so that any third person can not operate the switches carelessly. ● Place a sign "Under Operation" at the position easy to see. ● When releasing the brake on a vertically oriented actuator, exercise precaution not to pinch your hand or damage the work parts with the actuator dropped by gravity. <p>* Safety protection Fence : In the case that there is no safety protection fence, the movable range should be indicated.</p>

No.	Operation Description	Description
6	Trial Operation	<ul style="list-style-type: none"> ● When the work is carried out with 2 or more persons, make it clear who is to be the leader and who to be the follower(s) and communicate well with each other to ensure the safety of the workers. ● After the teaching or programming operation, perform the check operation one step by one step and then shift to the automatic operation. ● When the check operation is to be performed inside the safety protection fence, perform the check operation using the previously specified work procedure like the teaching operation. ● Make sure to perform the programmed operation check at the safety speed. Failure to do so may result in an accident due to unexpected motion caused by a program error, etc. ● Do not touch the terminal block or any of the various setting switches in the power ON mode. Failure to do so may result in an electric shock or malfunction.
7	Automatic Operation	<ul style="list-style-type: none"> ● Check before starting the automatic operation or rebooting after operation stop that there is nobody in the safety protection fence. ● Before starting automatic operation, make sure that all peripheral equipment is in an automatic-operation-ready state and there is no alarm indication. ● Make sure to operate automatic operation start from outside of the safety protection fence. ● In the case that there is any abnormal heating, smoke, offensive smell, or abnormal noise in the product, immediately stop the machine and turn OFF the power switch. Failure to do so may result in a fire or damage to the product. ● When a power failure occurs, turn OFF the power switch. Failure to do so may cause an injury or damage to the product, due to a sudden motion of the product in the recovery operation from the power failure.

No.	Operation Description	Description
8	Maintenance and Inspection	<ul style="list-style-type: none"> ● When the work is carried out with 2 or more persons, make it clear who is to be the leader and who to be the follower(s) and communicate well with each other to ensure the safety of the workers. ● Perform the work out of the safety protection fence, if possible. In the case that the operation is to be performed unavoidably inside the safety protection fence, prepare the “Stipulations for the Operation” and make sure that all the workers acknowledge and understand them well. ● When the work is to be performed inside the safety protection fence, basically turn OFF the power switch. ● When the operation is to be performed inside the safety protection fence, the worker should have an emergency stop switch at hand with him so that the unit can be stopped any time in an emergency. ● When the operation is to be performed inside the safety protection fence, in addition to the workers, arrange a watchman so that the machine can be stopped any time in an emergency. Also, keep watch on the operation so that any third person can not operate the switches carelessly. ● Place a sign “Under Operation” at the position easy to see. ● For the grease for the guide or ball screw, use appropriate grease according to the Instruction Manual for each model. ● Do not perform the dielectric strength test. Failure to do so may result in a damage to the product. ● When releasing the brake on a vertically oriented actuator, exercise precaution not to pinch your hand or damage the work parts with the actuator dropped by gravity. ● The slider or rod may get misaligned OFF the stop position if the servo is turned OFF. Be careful not to get injured or damaged due to an unnecessary operation. ● Pay attention not to lose the cover or untightened screws, and make sure to put the product back to the original condition after maintenance and inspection works. <p>Use in incomplete condition may cause damage to the product or an injury.</p> <p>* Safety protection Fence : In the case that there is no safety protection fence, the movable range should be indicated.</p>
9	Modification and Dismantle	<ul style="list-style-type: none"> ● Do not modify, disassemble, assemble or use of maintenance parts not specified based at your own discretion.
10	Disposal	<ul style="list-style-type: none"> ● When the product becomes no longer usable or necessary, dispose of it properly as an industrial waste. ● When removing the actuator for disposal, pay attention to drop of components when detaching screws. ● Do not put the product in a fire when disposing of it. The product may burst or generate toxic gases.
11	Other	<ul style="list-style-type: none"> ● Do not come close to the product or the harnesses if you are a person who requires a support of medical devices such as a pacemaker. Doing so may affect the performance of your medical device. ● See Overseas Specifications Compliance Manual to check whether complies if necessary. ● For the handling of actuators and controllers, follow the dedicated instruction manual of each unit to ensure the safety.

Alert Indication

The safety precautions are divided into “Danger”, “Warning”, “Caution” and “Notice” according to the warning level, as follows, and described in the Instruction Manual for each model.

Level	Degree of Danger and Damage	Symbol
Danger	This indicates an imminently hazardous situation which, if the product is not handled correctly, will result in death or serious injury.	 Danger
Warning	This indicates a potentially hazardous situation which, if the product is not handled correctly, could result in death or serious injury.	 Warning
Caution	This indicates a potentially hazardous situation which, if the product is not handled correctly, may result in minor injury or property damage.	 Caution
Notice	This indicates lower possibility for the injury, but should be kept to use this product properly.	 Notice

Caution in Handling

1. Do not set speeds and accelerations/decelerations equal to or greater than the respective ratings.

If the actuator is operated at a speed or acceleration/deceleration exceeding the allowable value, abnormal noise or vibration, failure, or shorter life may result.

In the case of interpolated operation of combined axes, the speed and acceleration/deceleration settings should correspond to the minimum values among all combined axes.

2. Keep the load moment within the allowable value.

If the actuator is operated under a load equal to or greater than the allowable load moment, abnormal noise or vibration, failure, or shorter life may result. In an extreme case, flaking may occur.

3. Make sure to attach the actuator properly by following this instruction manual.

Using the product with the actuator not being certainly retained or affixed may cause abnormal noise, vibration, malfunction or shorten the product life.

1. Overview

1.1 Introduction

Thank you for purchasing the Easy All-in-One ROBO Cylinder (hereinafter referred to as “ERC2”). This manual explains the features and operating procedures of the product.

This product retains all benefits of the conventional ERC series, while incorporating new features that provide greater convenience and enhanced safety to the users.

Please read this manual carefully and handle the product with utmost care while ensuring its correct operation. Keep this manual in a convenient place so the relevant sections can be referenced readily when necessary.

When starting your system or in the event of failure, also refer to the operation manuals for the teaching pendant, PC software and other components you are using with this product.

This manual does not cover all possible operations other than normal operations, or unexpected events such as complex signal changes resulting from operating the product at critical timings. Accordingly, think of any item not specifically mentioned in this manual as “prohibited.”

- * We have made every effort to ensure accuracy of the information provided in this manual. Should you find an error, however, or if you have any comment, please contact IAI.
Keep this manual in a convenient place so it can be referenced readily when necessary.

1.2 Meaning of the Model Number

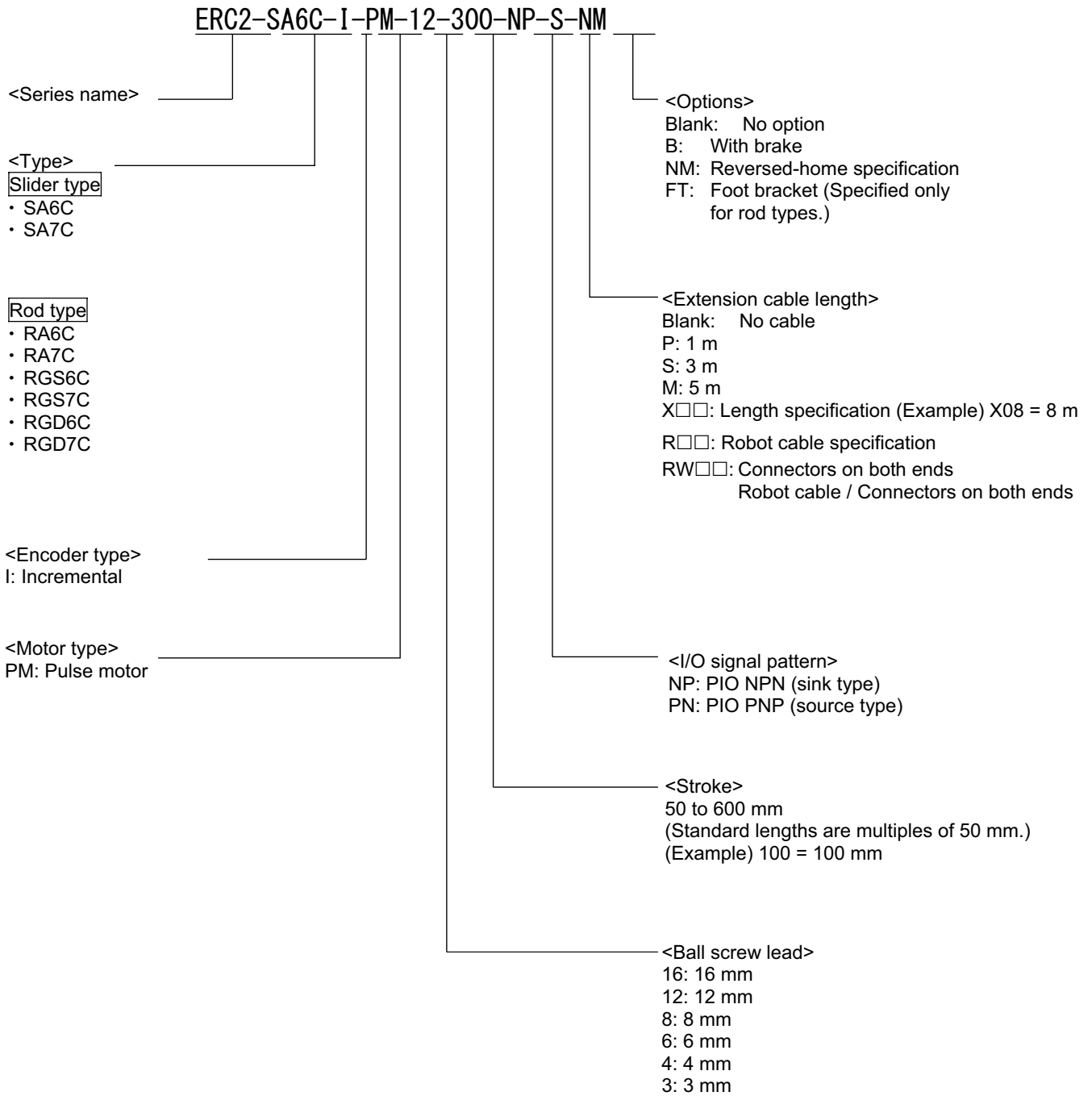

1.3 Specifications

	Model	Stroke (mm) and maximum speed (mm/sec) (Note 1)												Payload capacity (Note 2)		Rated acceleration	
		50	100	150	200	250	300	350	400	450	500	550	600	Horizontal	Vertical	Horizontal	Vertical
														(kg)	(kg)	(G)	(G)
Slider type	ERC2-SA6C-I-PM-12-□□□□	600										515	6~2	1.5~1	0.3	0.2	
	ERC2-SA6C-I-PM-6-□□□□	300										255	12	3~2.5	0.3	0.2	
	ERC2-SA6C-I-PM-3-□□□□	150										125	12	6~4	0.2	0.2	
	ERC2-SA7C-I-PM-16-□□□□	450 (400)											10~2	2.5~0.5	0.3	0.2	
	ERC2-SA7C-I-PM-8-□□□□	250											20~3.5	5~0.5	0.3	0.2	
	ERC2-SA7C-I-PM-4-□□□□	125											20	10~2	0.2	0.2	
Rod type	ERC2-RA6C-I-PM-12-□□□□	600										500	25~2.5	4.5~0.5	0.3	0.2	
	ERC2-RA6C-I-PM-6-□□□□	300										250	40~12	12~2.5	0.3	0.2	
	ERC2-RA6C-I-PM-3-□□□□	150										125	40	18~4	0.2	0.2	
	ERC2-RA7C-I-PM-16-□□□□	450 (400)											40~2	5~0.5	0.3	0.2	
	ERC2-RA7C-I-PM-8-□□□□	250 (200)											50~3.5	17.5~1	0.3	0.2	
	ERC2-RA7C-I-PM-4-□□□□	125											55~25	25~2	0.2	0.2	
	ERC2-RG6C-I-PM-12-□□□□	600										500	25~2.5	4.5~0.5	0.3	0.2	
	ERC2-RG6C-I-PM-6-□□□□	300										250	40~12	12~2.5	0.3	0.2	
	ERC2-RG6C-I-PM-3-□□□□	150										125	40	18~4	0.2	0.2	
	ERC2-RG7C-I-PM-16-□□□□	500											40~2	5~0.5	0.3	0.2	
	ERC2-RG7C-I-PM-8-□□□□	250											50~3.5	17.5~1	0.3	0.2	
	ERC2-RG7C-I-PM-4-□□□□	125											55~25	25~2	0.2	0.2	
	ERC2-RGD6C-I-PM-12-□□□□	600										500	25~2.5	4.5~0.5	0.3	0.2	
	ERC2-RGD6C-I-PM-6-□□□□	300										250	40~12	12~2.5	0.3	0.2	
	ERC2-RGD6C-I-PM-3-□□□□	150										125	40	18~4	0.2	0.2	
	ERC2-RGD7C-I-PM-16-□□□□	500											40~2	5~0.5	0.3	0.2	
	ERC2-RGD7C-I-PM-8-□□□□	250											50~3.5	17.5~1	0.3	0.2	
	ERC2-RGD7C-I-PM-4-□□□□	125											55~25	25~2	0.2	0.2	

(Note 1) The figures in blank bands indicate the maximum speeds for respective strokes. The maximum speeds during vertical operation are shown in parentheses.

(Note 2) The payload capacity is based on operation at the rated acceleration. In the case of a guide type, find the applicable payload capacity in the above table and subtract the weight of the guide to obtain the effective payload capacity.

1.3.1 Correlation Diagrams of Speed and Payload Capacity – Slider Type

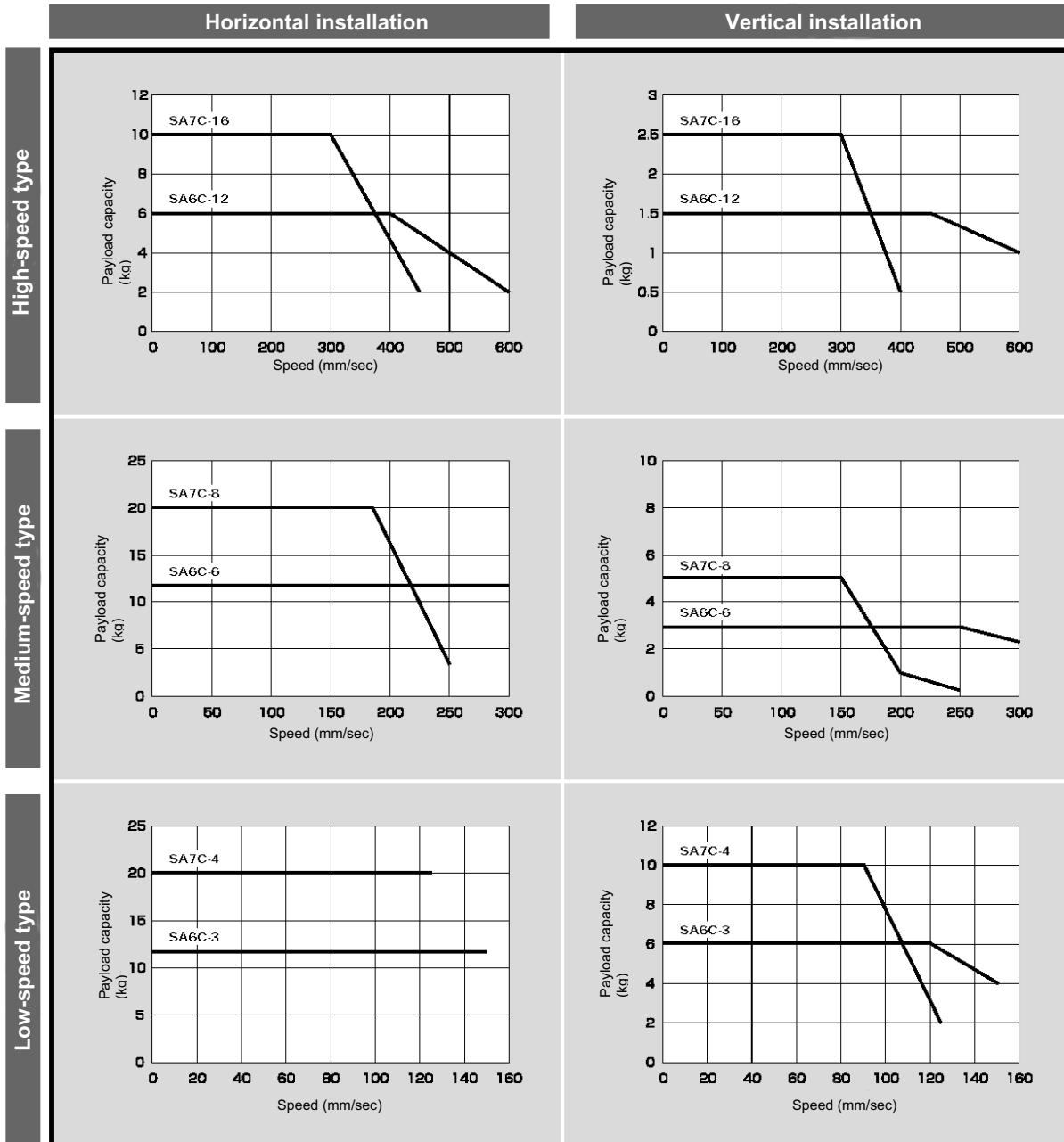

(Note) In the above graphs, the number after each type name indicates the lead.

1.3.2 Correlation Diagrams of Speed and Payload Capacity – Rod Type

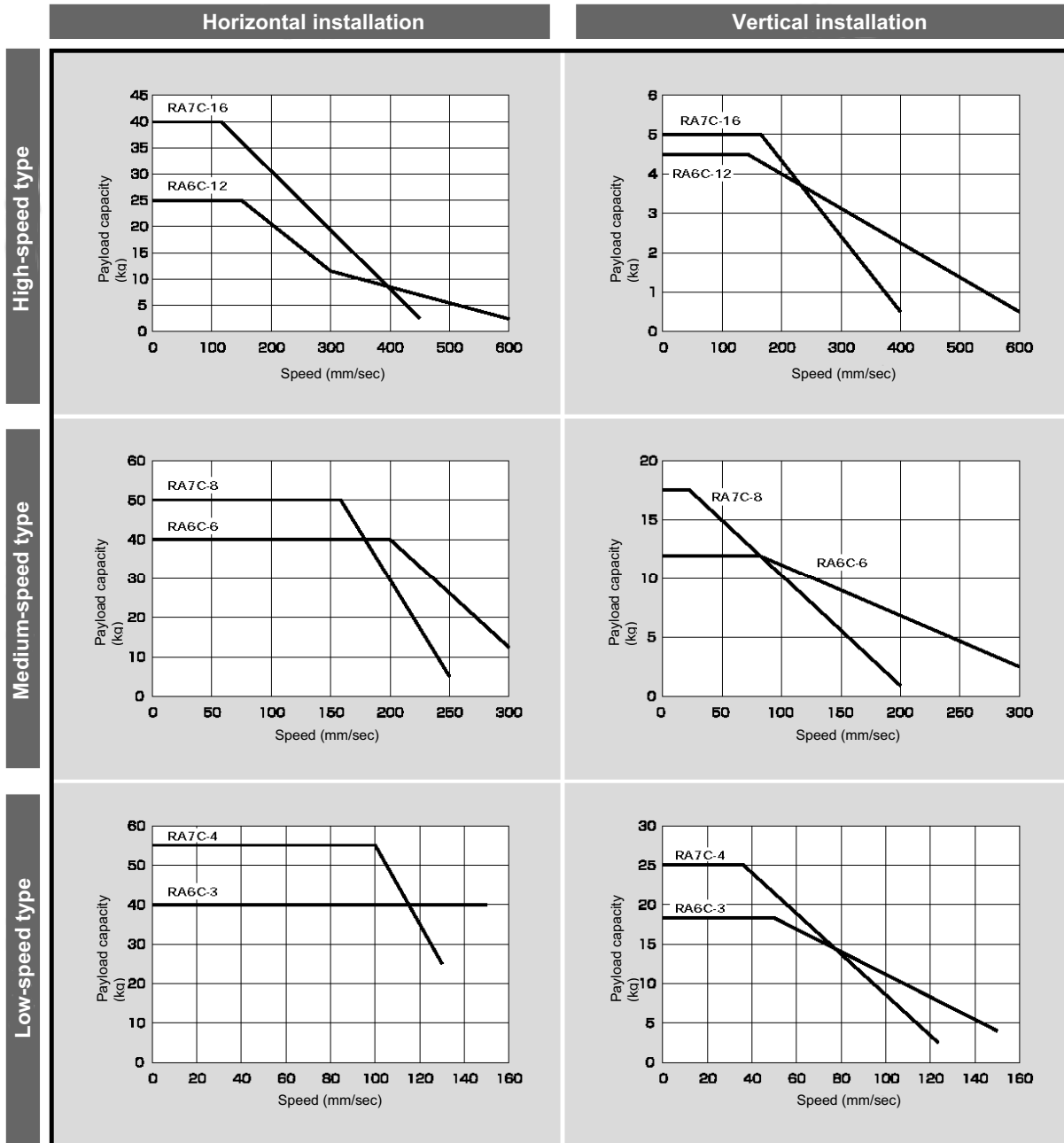

(Note) In the above graphs, the number after each type name indicates the lead.

⚠ Load Applied to the Actuator

(1) Slider type

- Keep the load applied to the slider below the value stated in the applicable specification item. In particular, pay attention to the moment applied to the slider, allowable overhang length and payload capacity.
- If the slider is used in an overhang application with the load extending in the Y-axis direction, keep moments M_a and M_c to one-half the rated moment or less to prevent the base from deforming.

(2) Rod type

- Keep the load applied to the rod below the value specified in the catalog.
- Make sure the center of the rod axis corresponds to the moving direction of the load.

- Application of lateral load may cause an actuator damage or breakdown.
- If the rod is to be subjected to lateral load, provide a guide or other support in the moving direction of the load.

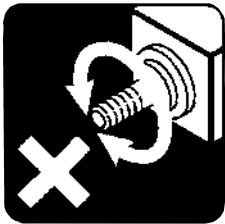

- Do not apply rotating torque to the rod (slide shaft).
 - * It will result in internal damages.

When tightening the nut at the tip of the rod, secure the rod using a wrench of size 13 (RA6C type) or 17 (RA7C type).

1.3.3 The sound pressure level of this product does not exceed 70 dB.

1.4 Warranty

1 Warranty Period

One of the following periods, whichever is shorter:

- 18 months after shipment from our company
- 12 months after delivery to the specified location

2 Scope of Warranty

Our products are covered by warranty when all of the following conditions are met. Faulty products covered by warranty will be replaced or repaired free of charge:

- (1) The breakdown or problem in question pertains to our product as delivered by us or our authorized dealer.
- (2) The breakdown or problem in question occurred during the warranty period.
- (3) The breakdown or problem in question occurred while the product was in use for an appropriate purpose under the conditions and environment of use specified in the operation manual and catalog.
- (4) The breakdown of problem in question was caused by a specification defect or problem, or by a quality issue with our product.

Note that breakdowns due to any of the following reasons are excluded from the scope of warranty:

- [1] Anything other than our product
- [2] Modification or repair performed by a party other than us (unless we have approved such modification or repair)
- [3] Anything that could not be easily predicted with the level of science and technology available at the time of shipment from our company
- [4] A natural disaster, man-made disaster, incident or accident for which we are not liable
- [5] Natural fading of paint or other symptoms of aging
- [6] Wear, depletion or other expected result of use
- [7] Operation noise, vibration or other subjective sensation not affecting function or maintenance

Note that the warranty only covers our product as delivered and that any secondary loss arising from a breakdown of our product is excluded from the scope of warranty.

3 Honoring the Warranty

As a rule, the product must be brought to us for repair under warranty.

4 Limited Liability

- (1) We shall assume no liability for any special damage, consequential loss or passive loss such as a loss of expected profit arising from or in connection with our product.
- (2) We shall not be liable for any program or control method created by the customer to operate our product or for the result of such program or control method.

5 Conditions of Conformance with Applicable Standards/Regulations, Etc., and Applications

- (1) If our product is combined with another product or any system, device, etc., used by the customer, the customer must first check the applicable standards, regulations and/or rules. The customer is also responsible for confirming that such combination with our product conforms to the applicable standards, etc. In such a case we will not be liable for the conformance of our product with the applicable standards, etc.
- (2) Our product is for general industrial use. It is not intended or designed for the applications specified below, which require a high level of safety. Accordingly, as a rule our product cannot be used in these applications. Contact us if you must use our product for any of these applications:
 - [1] Medical equipment pertaining to maintenance or management of human life or health
 - [2] A mechanism or mechanical equipment intended to move or transport people (such as a vehicle, railway facility or aviation facility)
 - [3] Important safety parts of mechanical equipment (such as safety devices)
 - [4] Equipment used to handle cultural assets, art or other irreplaceable items
- (3) Contact us at the earliest opportunity if our product is to be used in any condition or environment that differs from what is specified in the catalog or operation manual.

6 Other Items Excluded from Warranty

The price of the product delivered to you does not include expenses associated with programming, the dispatch of engineers, etc. Accordingly, a separate fee will be charged in the following cases even during the warranty period:

- [1] Guidance for installation/adjustment and witnessing of test operation
- [2] Maintenance and inspection
- [3] Technical guidance and education on operating/wiring methods, etc.
- [4] Technical guidance and education on programming and other items related to programs

1.5 Transportation and Handling

1.5.1 Handling before Unpacking

Exercise due caution when transporting or handling the box containing the actuator, by not applying impact on the box as a result of collision or dropping.

- If the box is heavy, one person should not carry it by himself.
- Place the box in a level surface.
- Do not step on the box.
- Do not place on the box any heavy object that may cause the box to deform or other object with a section where loads will concentrate.

1.5.2 Handling after Unpacking

Once removed out of the box, hold the actuator by the frame if it is a rod type, or by the base if it is a slider type.

- When carrying the actuator, be careful not to allow it to collide with other objects. In particular, pay attention to the front bracket, motor bracket and motor cover.
- Do not exert excessive force on each part of the actuator. In particular, pay attention to the motor cover and cables.
- When unpacking, exercise due caution not to let the actuator drop and sustain damage to its mechanism.
- If the actuator is damaged during the shipment or any of the items is found missing, please contact IAI's Technical Support immediately.

Supplement) Refer to 2.1, "Name of Each Part," for the name of each part of the actuator.

1.6 Installation Environment and Noise Elimination

Pay due attention to the installation environment of the controller.

1.6.1 Installation Environment

The installation environment must satisfy the following conditions:

No.	Use environment/condition
[1]	Not exposed to direct sunlight.
[2]	The actuator is not subject to irradiated heat from a large heat source, such as a heat treatment furnace.
[3]	Ambient temperature of 0 to 40°C.
[4]	Humidity of 85% or less without condensation.
[5]	Not exposed to corrosive or flammable gases.
[6]	Normal environment for assembly and operation not subject to significant dust.
[7]	Not exposed to oil mist or cutting fluid.
[8]	Not subject to vibration exceeding 0.3 G.
[9]	Not exposed to strong electromagnetic waves, ultraviolet light or radiation.
[10]	Chemical resistance is not considered at all in the design of this product.
[11]	The actuator and cables are not subject to electrical noise.

In general, the installation environment shall be such that the operator can work without wearing any protective gears.

1.6.2 Storage Environment

The storage environment shall conform to the installation environment, but special caution is required to prevent condensation if the actuator is to be stored for a long period of time.

Unless otherwise specified, the actuator is shipped without any desiccating agent placed in the box. If the actuator is to be stored in an environment subject to condensation, provide a non-condensing measure from outside the box or directly inside the box.

The actuator is designed to withstand storage temperatures of up to 60°C for a short period of time. If the storage period will extend beyond one month, however, keep the ambient temperature below 50°C.

1.6.3 Power Supply

The control/motor-drive power supply specification is 24 VDC \pm 10% (2 A max).

1.6.4 Noise Elimination

This section explains how to eliminate noise in the use of the controller.

(1) Wiring and power supply

- [1] Provide a dedicated class D grounding using a wire with a size of 0.75 mm² or larger.

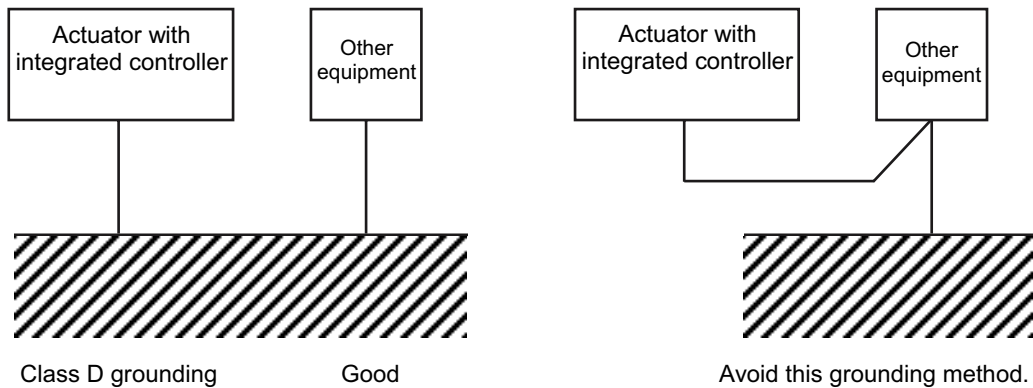

- [2] Precautions regarding wiring method
Wire extension cables separately from high-power lines for power circuits, etc. (Do not bundle them together or place them in the same cable duct.)

(2) Noise sources and elimination

Among the numerous noise sources, solenoid valves, magnet switches and relays are of particular concern when building a system. Noise from these sources can be eliminated by implementing the measures specified below.

[1] AC solenoid valves, magnet switches and relays

Measure: Install a surge absorber in parallel with the coil.

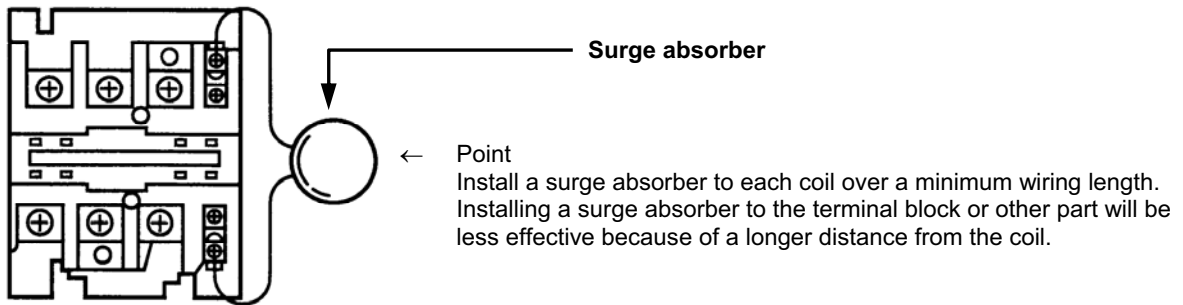

[2] DC solenoid valves, magnet switches and relays

Measure: Install a diode in parallel with the coil. Determine the diode capacity in accordance with the load capacity.

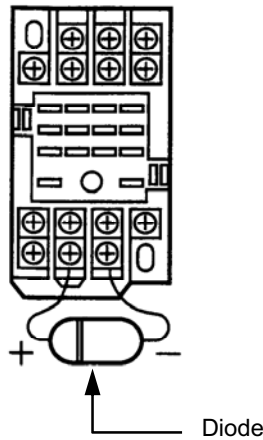

In a DC circuit, connecting a diode in reverse polarity will damage the diode, internal parts of the controller and/or DC power supply, so exercise due caution.

1.7 Cabling

- The standard extension cables have excellent flexibility to withstand fatigue from flexural loads, but they are not robot cables. Therefore, avoid storing the standard extension cables in movable cable ducts laid at a small radius. If they must be stored in movable cable ducts, use robot cables.
- In an application where the cable cannot be fixed, keep the cable from receiving a deflecting load exceeding its own weight, use a self-standing cable hose, provide a large bending radius along the wiring path, or provide other measure to minimize the load applied to the cable.
- Do not cut the cable for the purpose of extension, length reduction or reconnection.

If you intend to change the cable layout, please consult IAI.

Prohibitions/Notes on Handling Cables

When designing an application system using this actuator, incorrect wiring or connection of each cable may cause unexpected problems such as a disconnected cable or poor contact, or even a runaway system. This section explains prohibited handling of cables. Read the information carefully to connect the cables properly.

1. Do not let the cable flex at a single point.

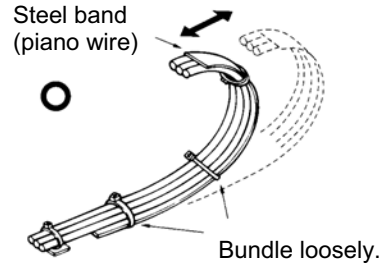
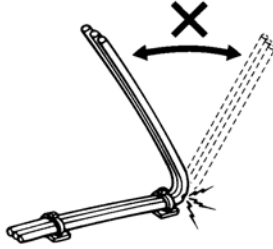

2. Do not let the cable bend, kink or twist.

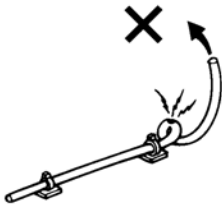

3. Do not pull the cable with a strong force.

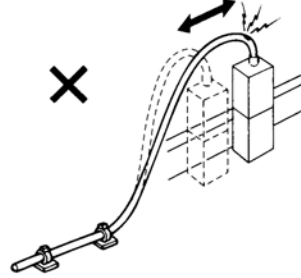

4. Do not let the cable receive a turning force at a single point.
5. When fixing the cable, provide a moderate slack and do not tension it too tight.

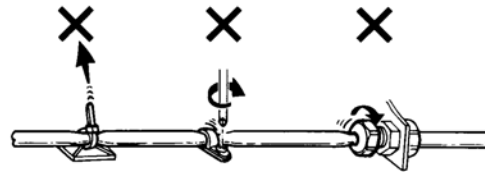
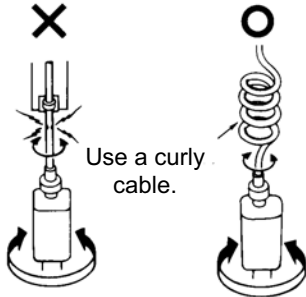

6. Do not pinch, drop a heavy object onto or cut the cable.

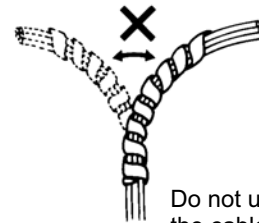
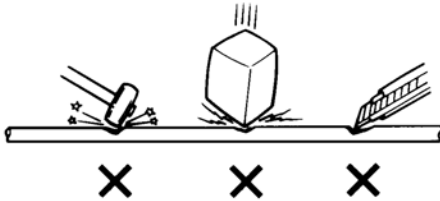

Do not use a spiral tube where the cable flexes frequently.

7. Notes on use of cable tracks

- The supplied cables are not robot cables, so do not store them in cable tracks.

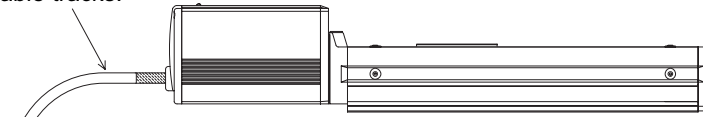

- Always use a robot cable for each relay cable.

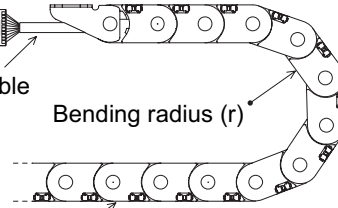

- Use a cable track with a bending radius (r) of 50 mm or more.

- PIO line, communication line, power and driving lines are to be put separately from each other and do not tie them together. Arrange so that such lines are independently routed in the duct.

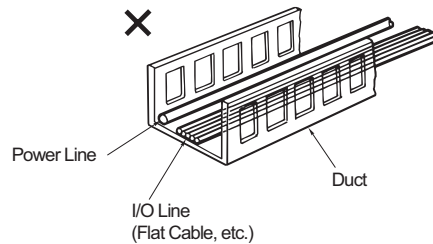

Follow the instructions below when using a cable track.

- If there is an indication to the cable for the space factor in a cable track, refer to the wiring instruction given by the supplier when storing the cable in the cable track.
- Avoid the cables to get twined or twisted in the cable track, and also to have the cables move freely and do not tie them up. (Avoid tension being applied when the cables are bent.)

Do not pile up cables. It may cause faster abrasion of the sheaths or cable breakage.

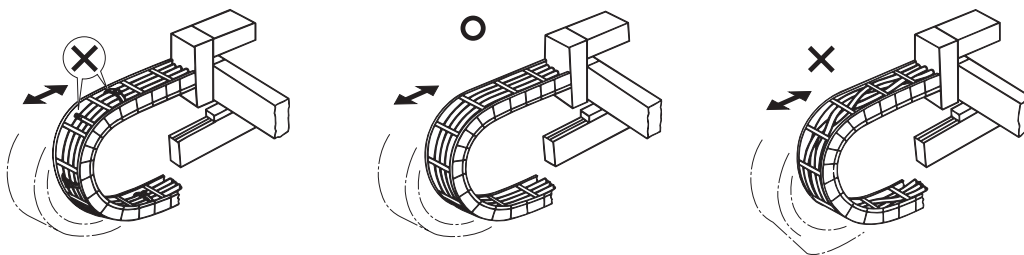

2. Installation

2.1 Name of Each Part

2.1.1 Slider Type (SA6C/SA7C)

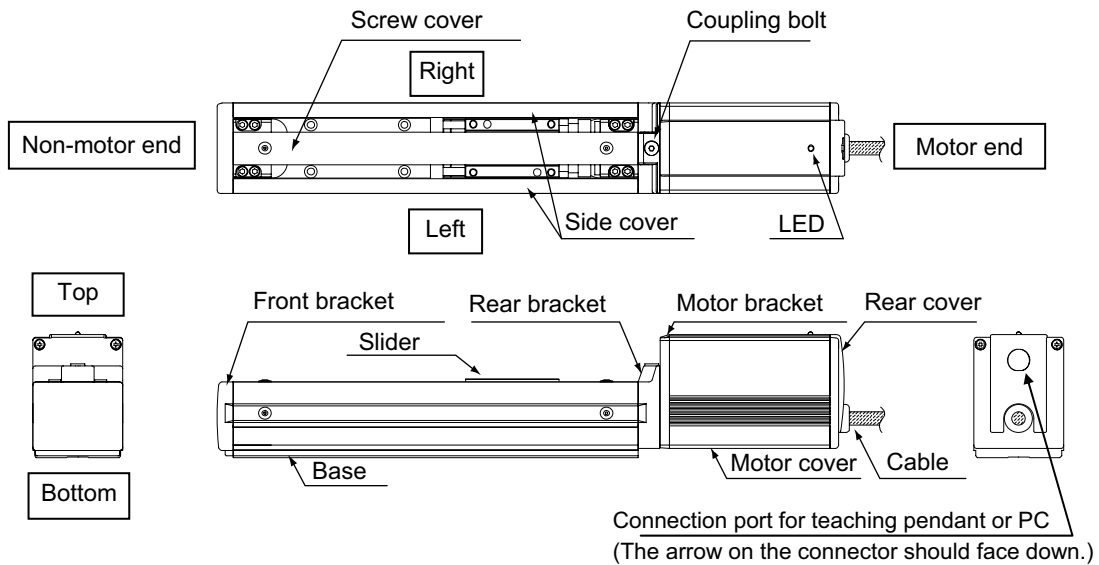

2.1.2 Rod Type (RA6C/RA7C)

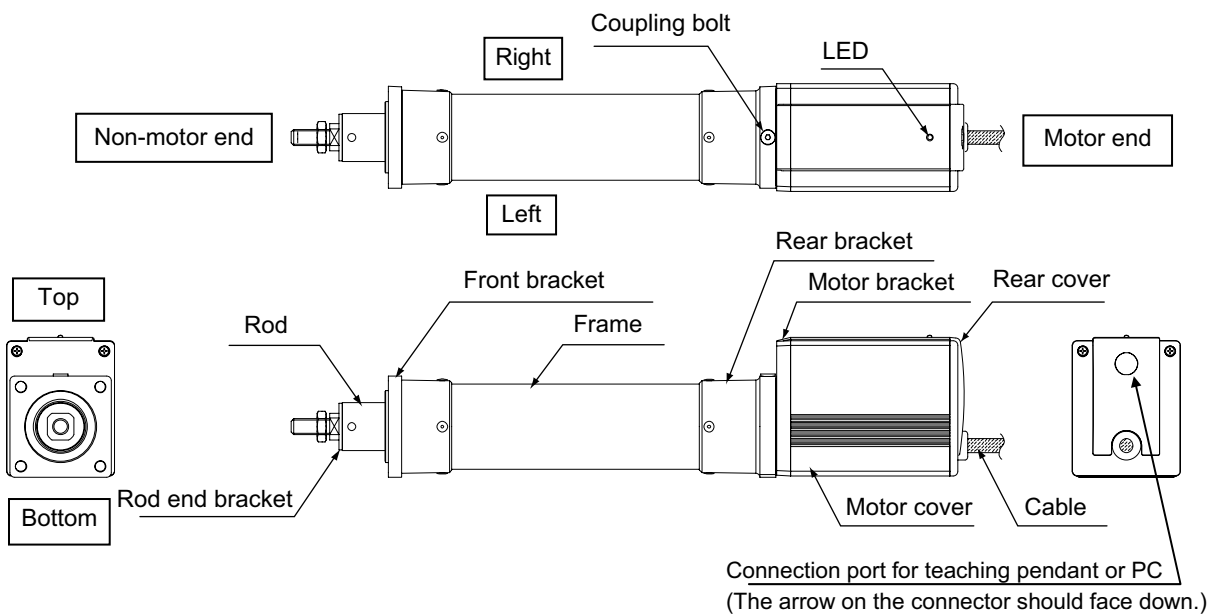

2.1.3 (1) Rod Type with a Single Guide (RGS6C/RGS7C)

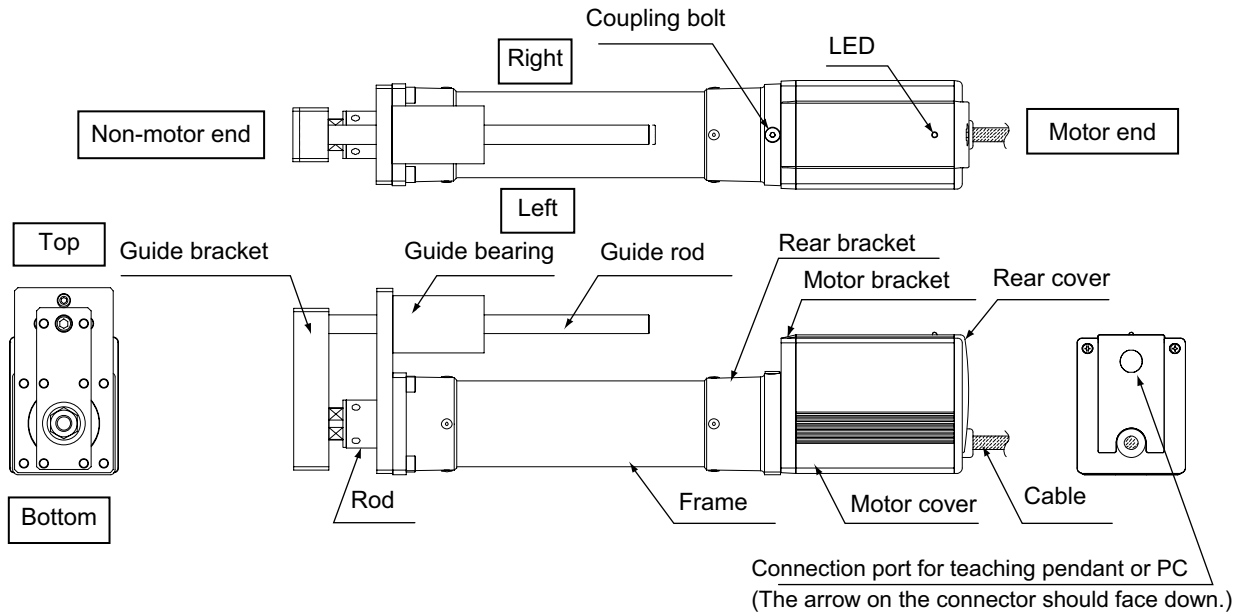

(2) Rod Type with Double Guides (RGD6C/RGD7C)

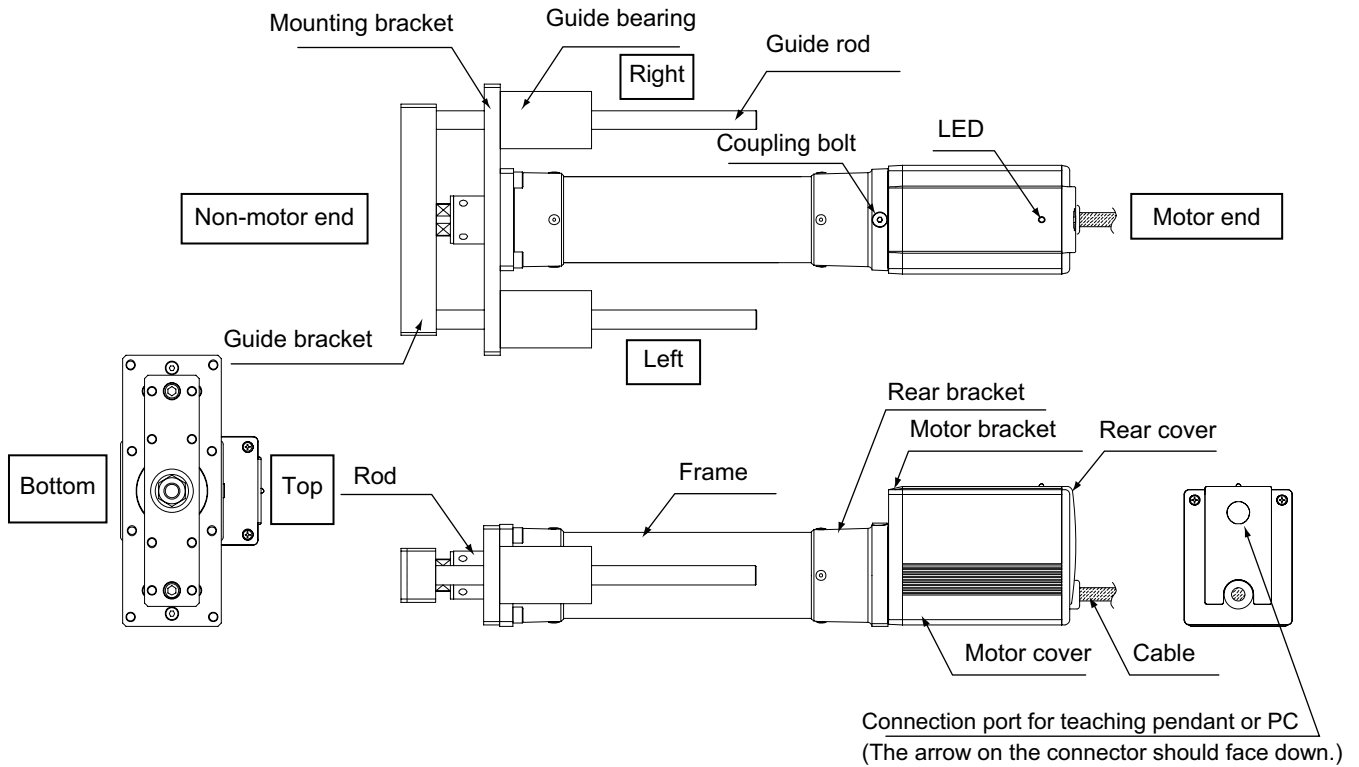

2.2 Installation

2.2.1 Slider Type

- Installing the actuator

The actuator-mounting surface must be a machined surface or have an equivalent flatness.

The side and bottom faces of the actuator base are parallel with the guides. If high slide accuracy is required, install the actuator by using these surfaces as references.

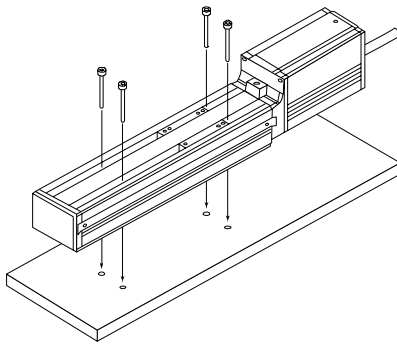

Slider type

Install the actuator in the mounting holes provided in the base. Secure the actuator in place using M4 hex cap bolts.

(Note) Reduced flatness due to installation of an overhang load will cause the base to deform and inhibit smooth movement of the slider. If the slider movement becomes heavier on the motor end or the slider begins generating noise, correct the flatness. Otherwise, the slider mechanism may end its life prematurely.

2.2.2 Rod Type

A rod-type actuator can be installed in the following two ways:

- Affixing with a flange

Install the actuator by tightening from the motor end side with hex cap bolts using the holes provided in the flange.

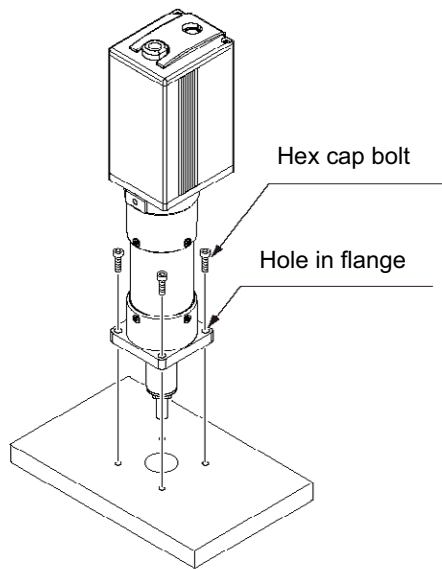

⚠ Caution: If the actuator is installed horizontally, exercise caution not to let the actuator receive excessive forces.

Flange tightening bolts

Model	Nominal thread size	Tightening torque
RA6C	M5	3.4 N·m (0.35 kgf·m)
RA7C	M6	5.4 N·m (0.55 kgf·m)

- Affixing through holes in a flange

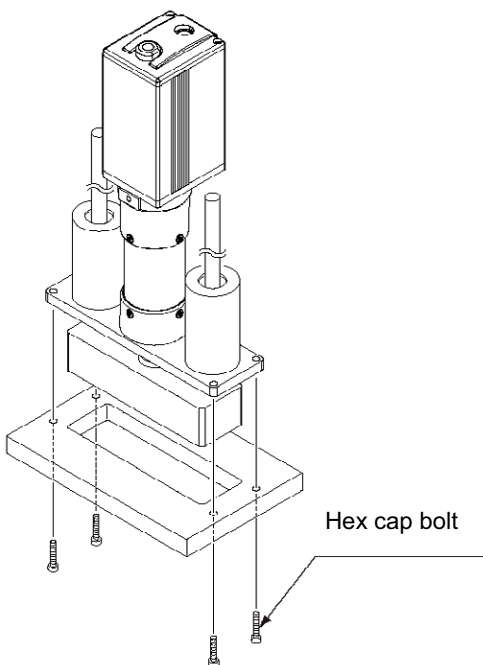

⚠ Caution: If the actuator is installed horizontally, exercise caution not to let the actuator receive excessive forces.

Flange tightening bolts

Model	Nominal thread size	Tightening torque
RGD6C	M5	Steel bolt-bearing surface: 7.3 N·m Aluminum bolt-bearing surface: 3.4 N·m
RGD7C	M6	Steel bolt-bearing surface: 12.3 N·m Aluminum bolt-bearing surface: 5.4 N·m

- Affixing with foot brackets (optional)

If optional foot brackets are used, install the foot brackets using hex cap bolts.

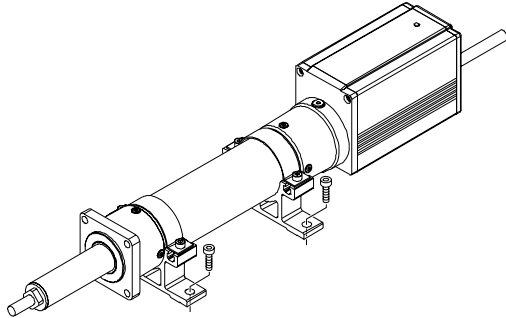

Foot-bracket tightening bolts

Model	Nominal thread size	Tightening torque
RA6C RGS6C RGD6C	M6	5.4 N·m (0.55 kgf·m)
RA7C RGS7C RGD7C	M8	11.5 N·m (1.17 kgf·m)

2.2.3 Installing the Load

- Slider Type

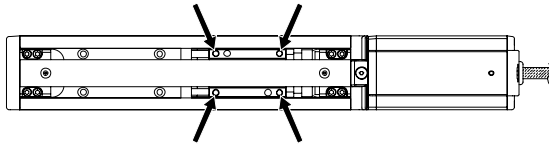

Four tapped holes are provided in the slider, so affix the load using these holes (indicated by arrows in the figure shown to the left).

Type	Slider mounting hole
SA6C, SA7C	M5, depth 9 mm

Nominal thread size	Tightening torque	
	Bolt bearing surface: steel	Bolt bearing surface: aluminum
M5	7.3 N·m (0.74 kgf·m)	3.4 N·m (0.35 kgf·m)

The affixing method of the load shall conform to the installation method of the actuator.

In an application where the actuator is moved with the slider fixed, install the load using the tapped holes in the slider in the same manner.

The slider has two reamed holes. Use these holes when high repeatability is required for load installation/removal. When fine-tuning the squareness of the load, etc., make adjustment by using one of these two reamed holes in the slider.

Type	Reamed hole
SA6C, SA7C	φ5, H10, depth 10 mm

- Rod Type

A bolt is attached on the rod end bracket, so use this bolt to affix the load. (Use the supplied nut, if necessary.)

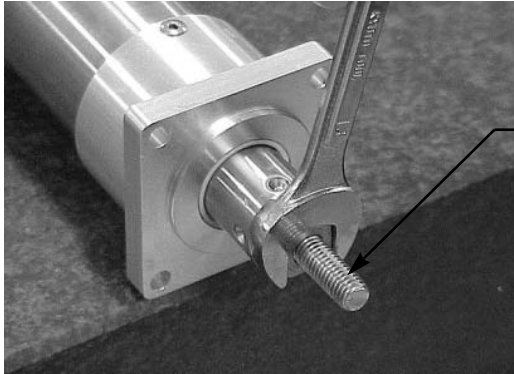

Rod end bracket

Model	Rod end bracket
RA6C	M8, length 18 mm
RA7C	M10, length 21 mm

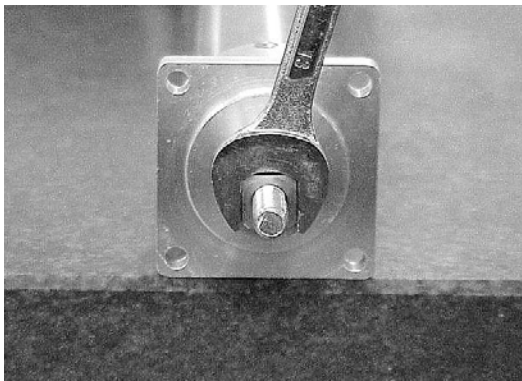

Note) Apply a spanner wrench at the rod end bracket to prevent the rod from receiving any rotating moment when the load is installed. Applying excessive rotating moment to the rod may damage the rod.
 RA6C: Width across flats 13 mm
 RA7C: Width across flats 17 mm

- Rod type with a guide(s)

Tapped holes are provided in the guide bracket. Affix the load using these holes (shown by the arrows in the figures at left).

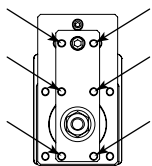

Single guides

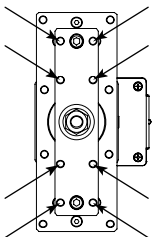

Double guides

Model	Nominal thread size
RGS6C	M5
RGD6C	M5
RGS7C	M6
RGD7C	M6

Nominal thread size	Tightening torque	
	Bolt bearing surface: steel	Bolt bearing surface: aluminum
M5	7.3 N·m (0.74 kgf·m)	3.4 N·m (0.35 kgf·m)
M6	12.3 N·m (1.26 kgf·m)	5.4 N·m (0.55 kgf·m)

3. Wiring

3.1 Basic Structure

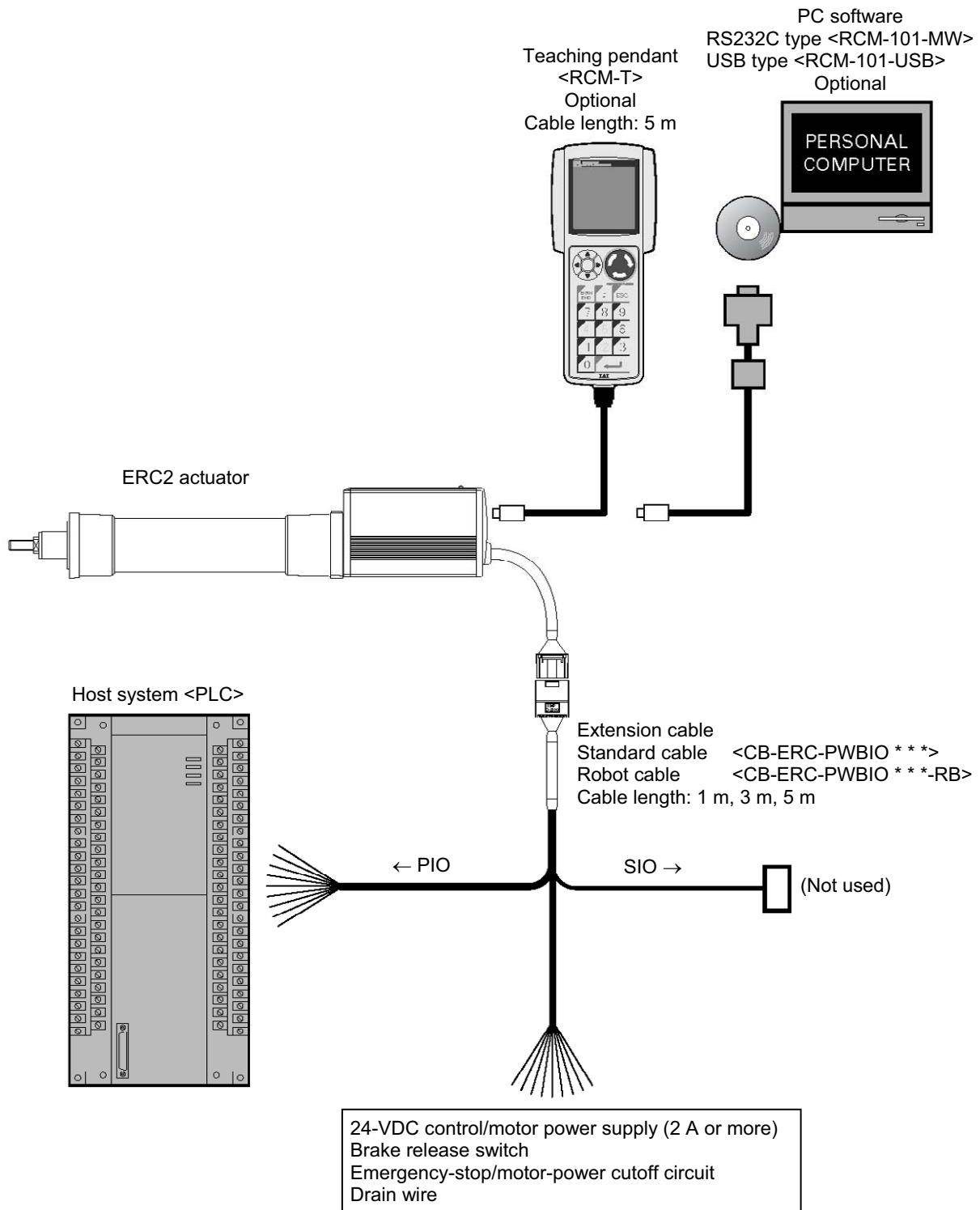

● Connection diagram

[1] When the control board is of the NPN specification [sink type]

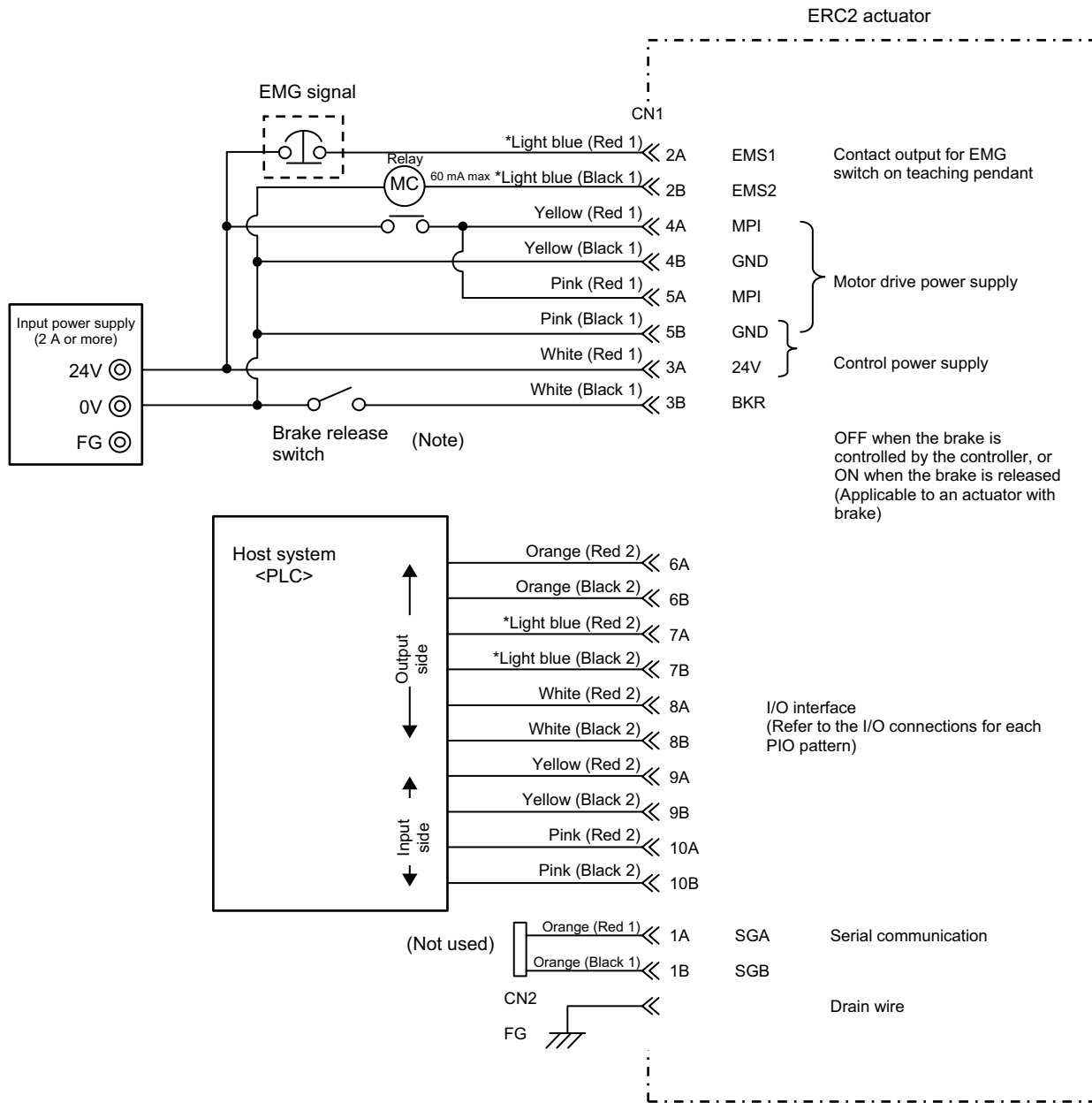

* In the case of a robot cable, the wire colors change as follows.

Wire color	Pin number
Gray (Red 1)	2A
Gray (Black 1)	2B
Gray (Red 2)	7A
Gray (Black 2)	7B

(Note) To release the brake, connect a switch between BKR and 0 V and turn on the switch.

[2] When the control board is of the PNP specification [source type]

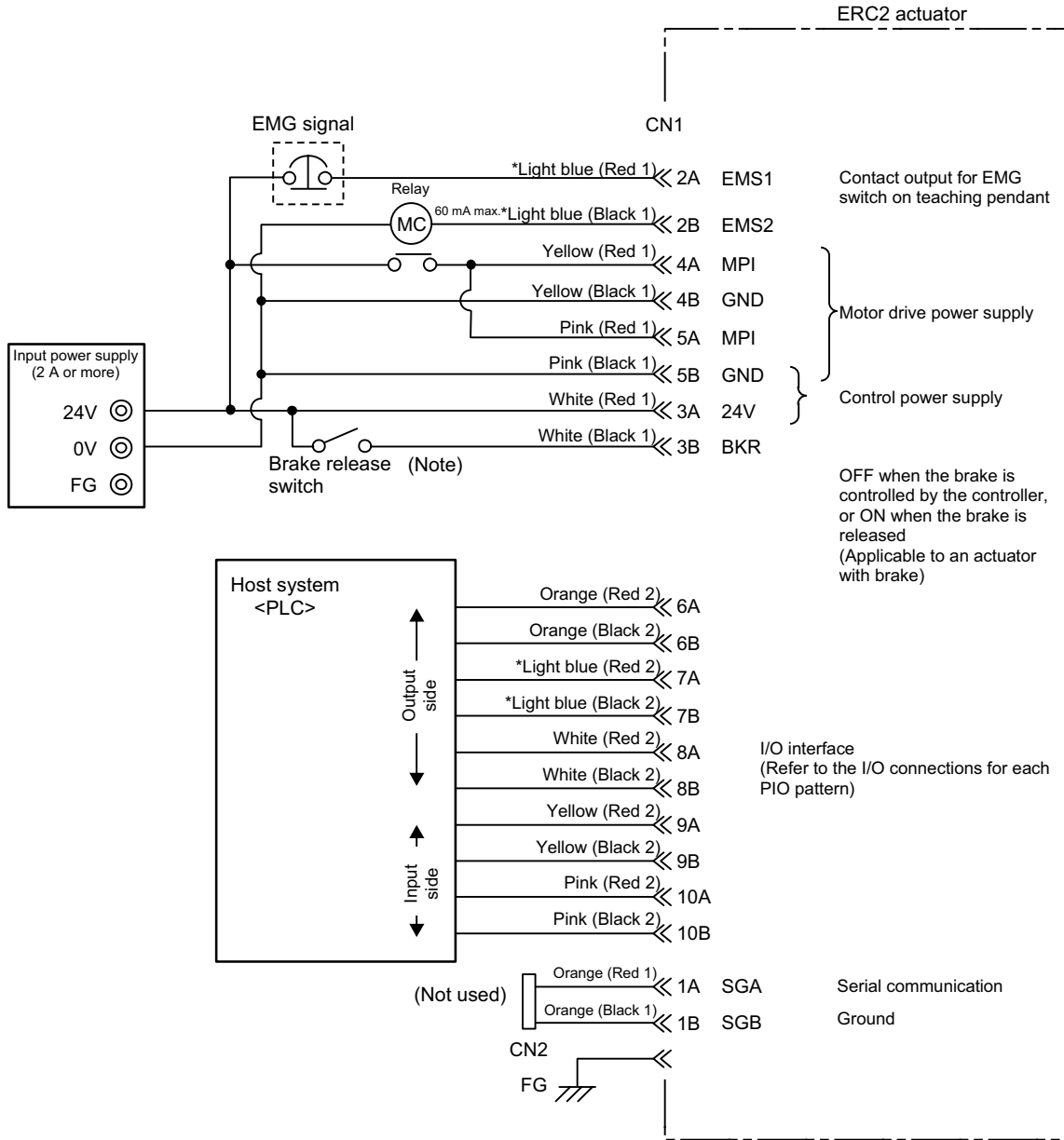

* In the case of a robot cable, the wire colors change as follows.

Wire color	Pin number
Gray (Red 1)	2A
Gray (Black 1)	2B
Gray (Red 2)	7A
Gray (Black 2)	7B

(Note) To release the brake, connect a switch between BKR and 24 V and turn on the switch.

3.2 Configuration Using a SIO Converter

If any of the following conditions applies, use a SIO converter to connect the teaching pendant or PC:

- [1] The actuator's rear cover cannot be reached and therefore the teaching pendant or PC cannot be connected.
- [2] Want to execute movement operation or parameter edit for all axes when multiple axes are connected to the single equipment.

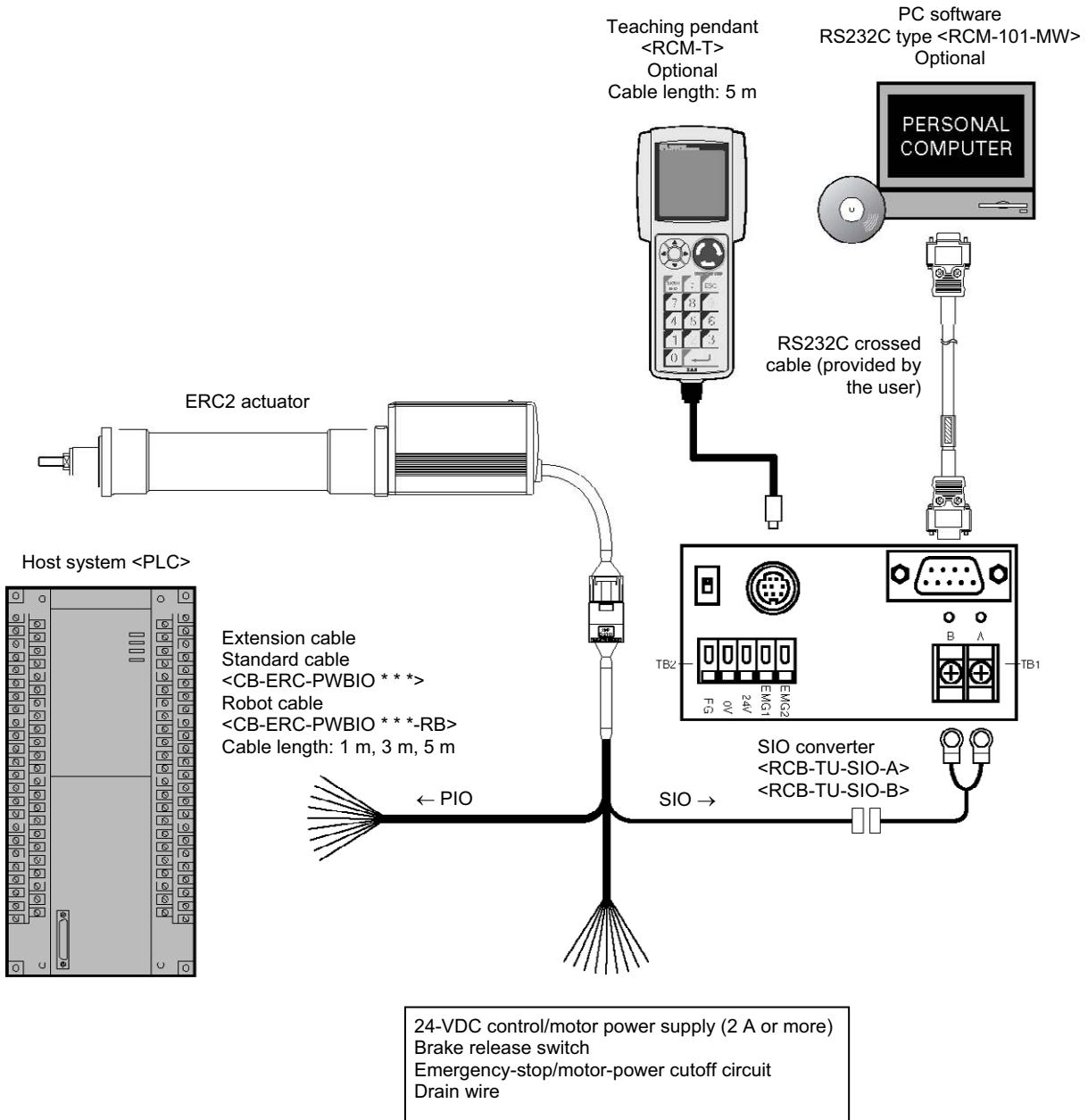

Caution: Do not connect a teaching pendant and a PC at the same time. If both are connected at the same time, a communication error (message level) will occur.

● Connection diagram

[1] When the control board is of the NPN specification [sink type]

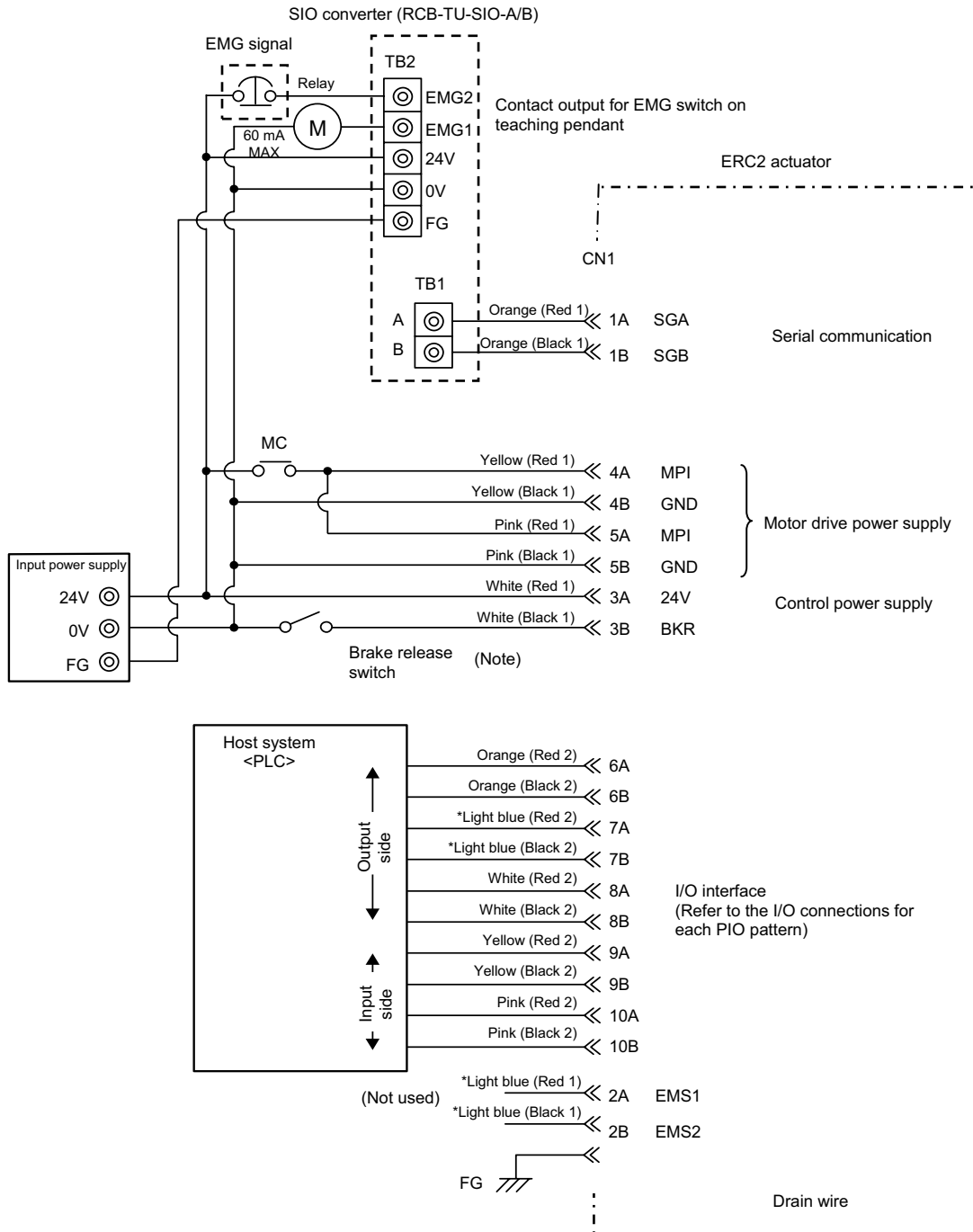

* In the case of a robot cable, the wire colors change as follows.

Wire color	Pin number
Gray (Red 1)	2A
Gray (Black 1)	2B
Gray (Red 2)	7A
Gray (Black 2)	7B

(Note) To release the brake, connect a switch between BKR and 0 V and turn on the switch.

[2] When the control board is of the PNP specification [source type]

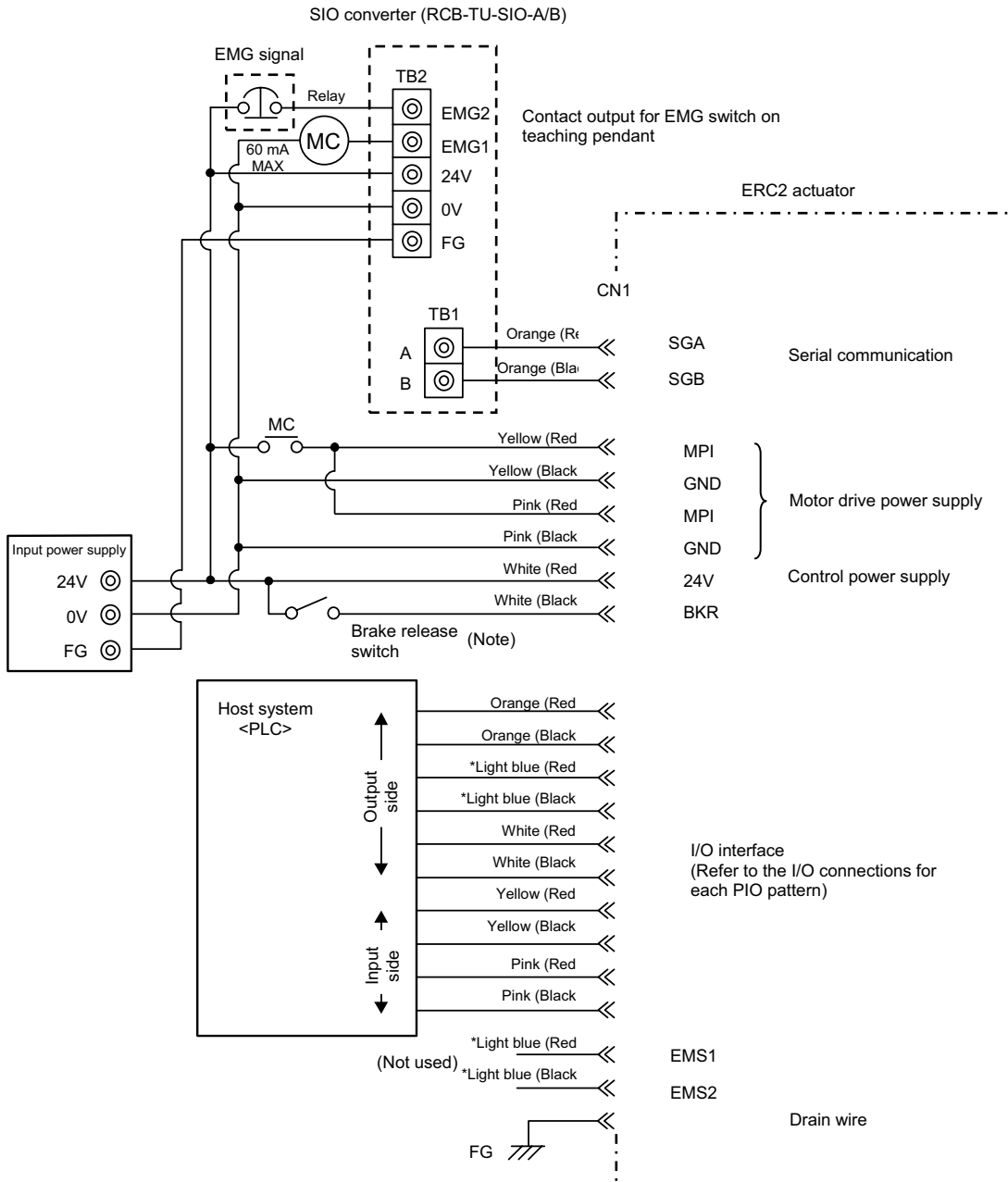

* In the case of a robot cable, the wire colors change as follows.

Wire color	Pin number
Gray (Red 1)	2A
Gray (Black 1)	2B
Gray (Red 2)	7A
Gray (Black 2)	7B

(Note) To release the brake, connect a switch between BKR and 24 V and turn on the switch.

3.2.1 Example of Connecting Multiple Axes Using Link Cables

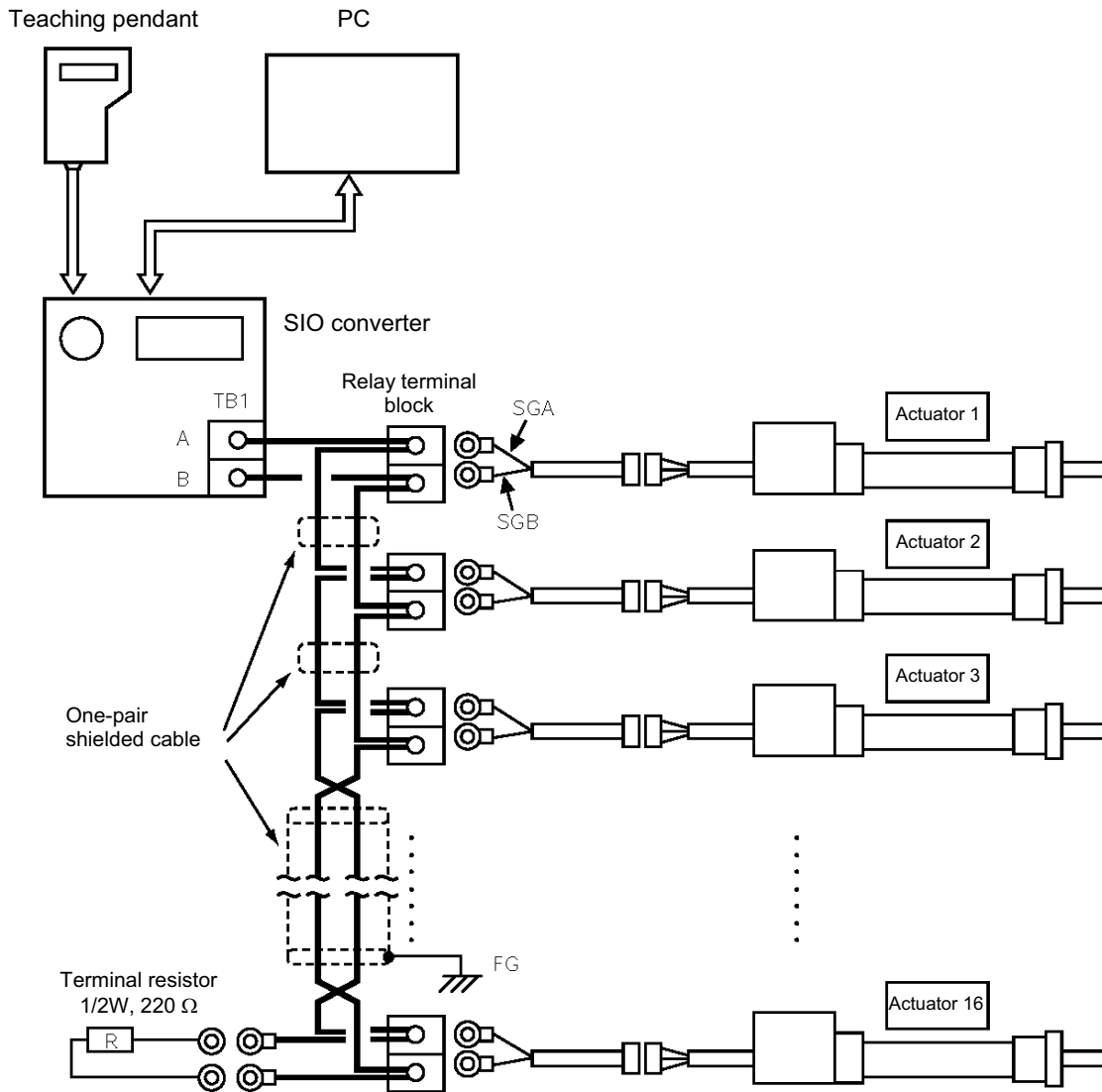

- (Note 1) If the total length of the communication cable is 10 m or longer and you experience communication errors, connect a terminal resistor to the last axis.
- (Note 2) If the actuators use different power supplies, align 0 [V] on all power supplies.
- (Note 3) Connect the shielded wire of each axis to FG.
- (Note 4) If the overall length of link cable exceeds 30 m, use wire of 22AWG or larger size.

3.2.2 Address Assignment

If multiple axes are connected, a slave number must be assigned to each axis so that the host can recognize the corresponding actuator.

Assign addresses in the setting screen of the teaching pendant or PC.

- Overview of operation on the PC
 - [1] Open the main window → [2] Click **Setup (S)** → [3] Bring the cursor to **Controller Setup (C)** → [4] Bring the cursor to **Assign Address (N)** and click the mouse → [5] Enter an appropriate number in the address table.
- Overview of operation on the teaching pendant RCM-T
 - [1] Open the User Adjustment screen → [2] Use the ▼ key to bring the cursor to **Address No.** → [3] Enter an appropriate address and press the ENTER key → [4] Enter "2" under **Adjustment No.** and press the ENTER key.
- Overview of operation on the simple teaching pendant RCM-E
 - [1] Open the User Adjustment screen → [2] Press the ENTER key to open the screen showing **Address No.** → [3] Enter an appropriate address and press the ENTER key → [4] Enter "2" under **Adjustment No.** and press the ENTER key.

Refer to the operation manual for your teaching pendant or PC software for the specific operating procedure.

 **Caution:** In the actual process of assigning addresses, the teaching pendant or PC and the target actuator must have a one-on-one link. Therefore, disconnect the communication cables (SGA/SGB) from other axes to tentatively provide a condition where not more than one axis is connected.

3.3 Configuration Using an Isolated PIO Terminal Block

If either of the following conditions applies, use an isolated PIO terminal block:

- [1] Want to insulate the control power supply from the PIO power supply.
- [2] Want to change the I/O logic of the control board.

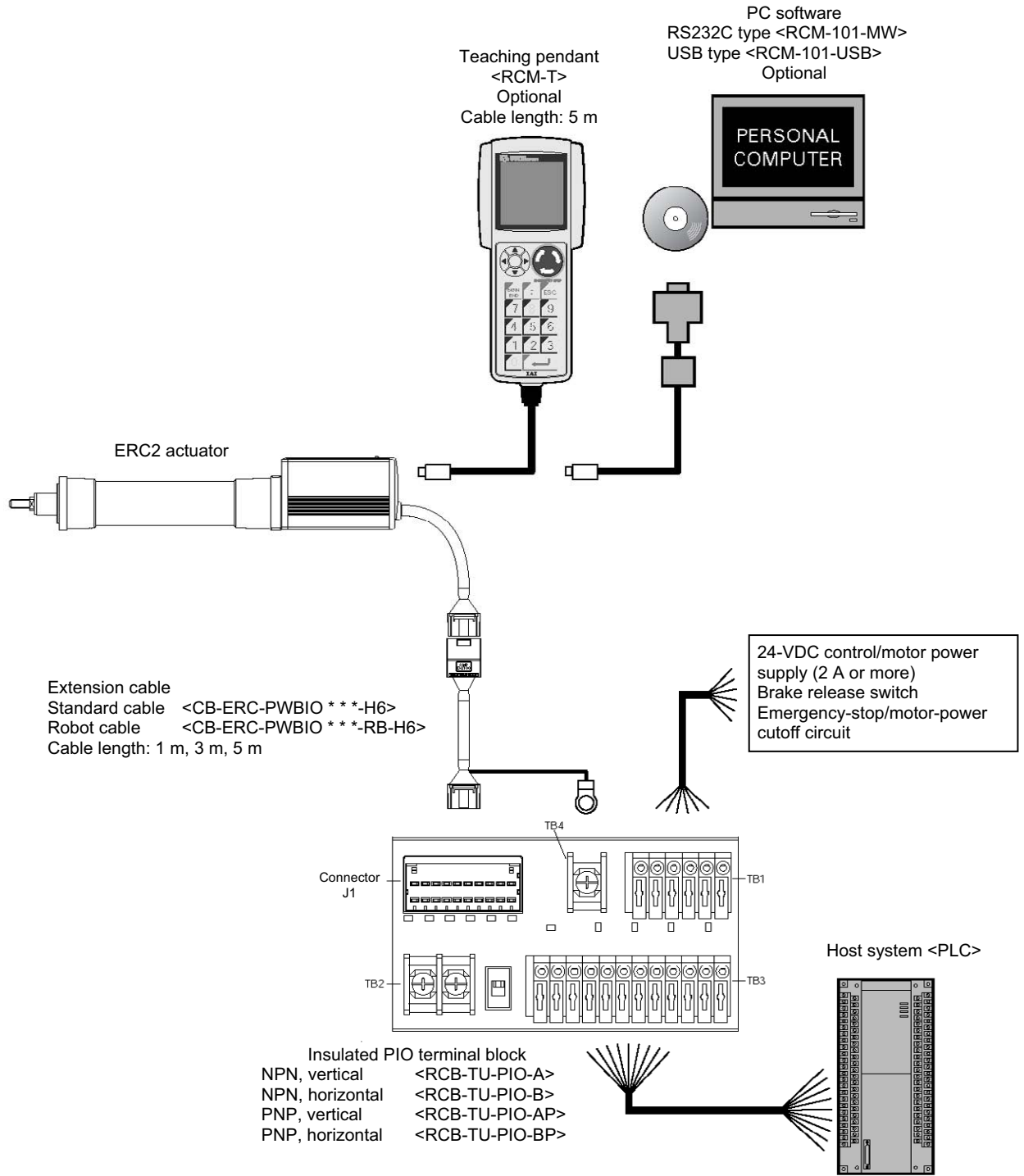

● Connection diagram

[1] When the control board is of the NPN specification [sink type]

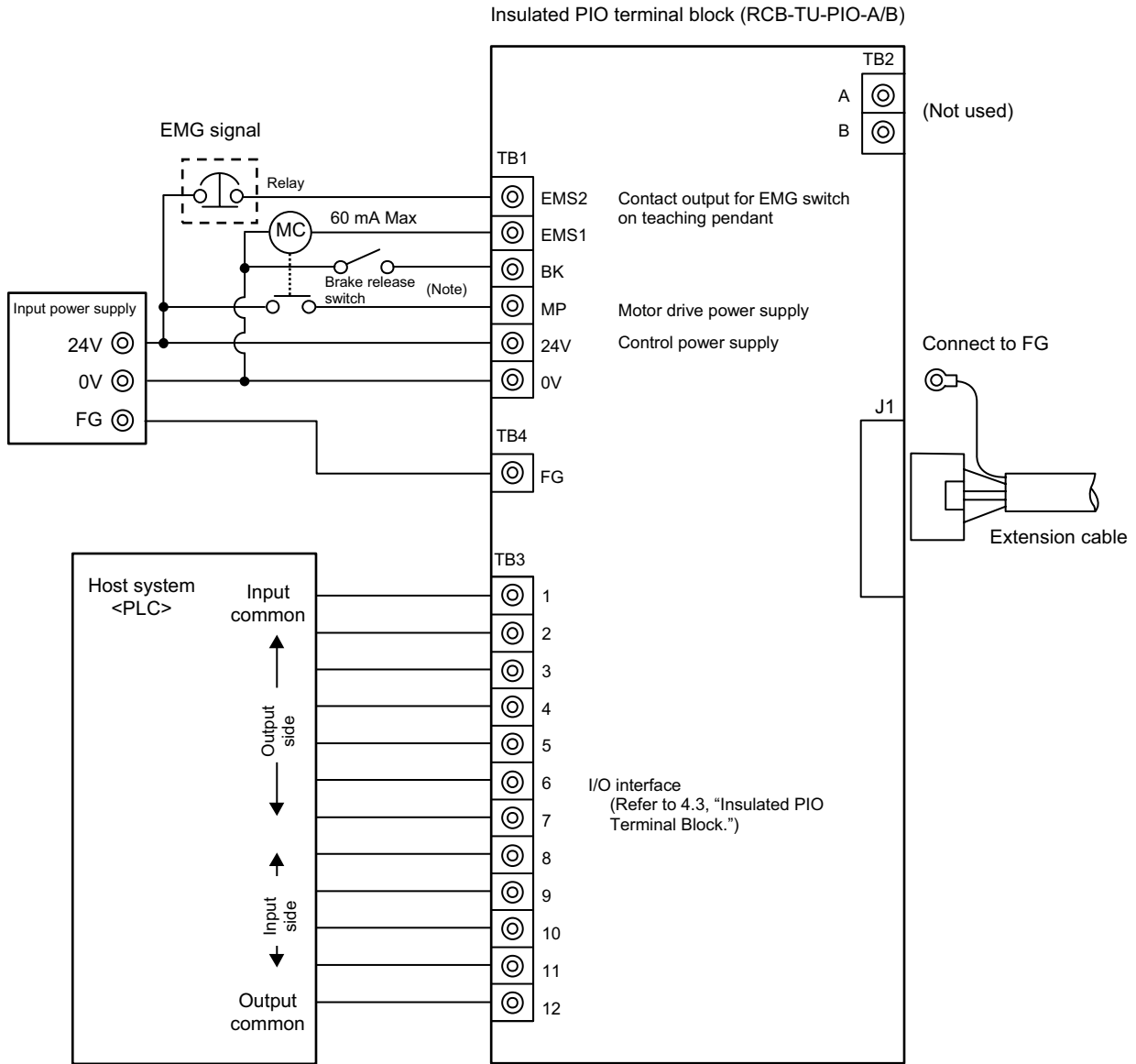

	[1] Insulate the power supply	[2] The I/O logic of the PLC is PNP
Input common	24 V	0 V
Output common	0 V	24 V

(Note) To release the brake, connect a switch between the TB1-BK terminal and 0 V and turn on the switch.

[2] When the control board is of the PNP specification [source type]

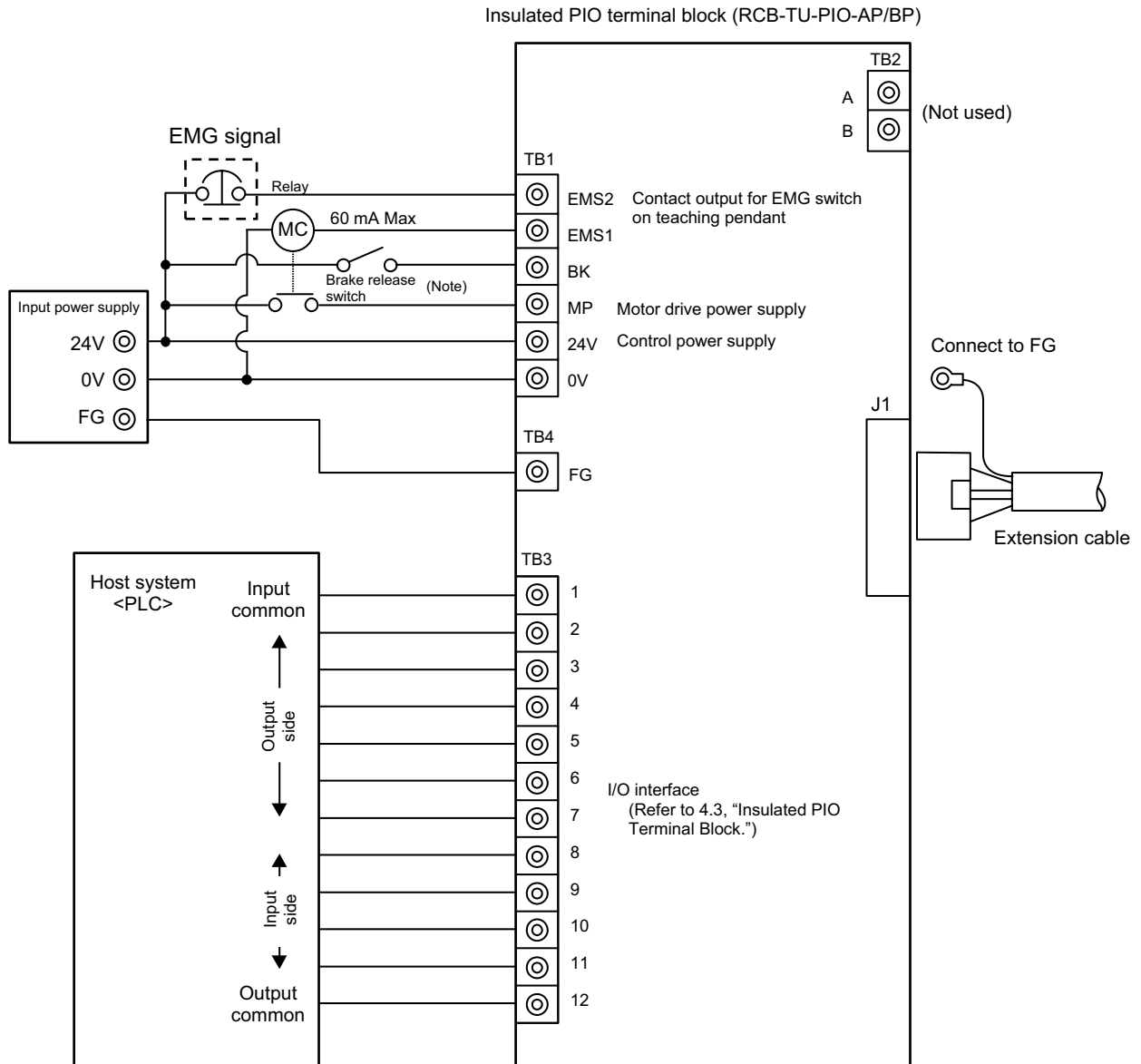

	[1] Insulate the power supply	[2] The I/O logic of the PLC is PNP
Input common	0 V	24 V
Output common	24 V	0 V

(Note) To release the brake, connect a switch between the TB1-BK terminal and 24 V and turn on the switch.

3.4 Configuration Using Both SIO Converter and Isolated PIO Terminal Block

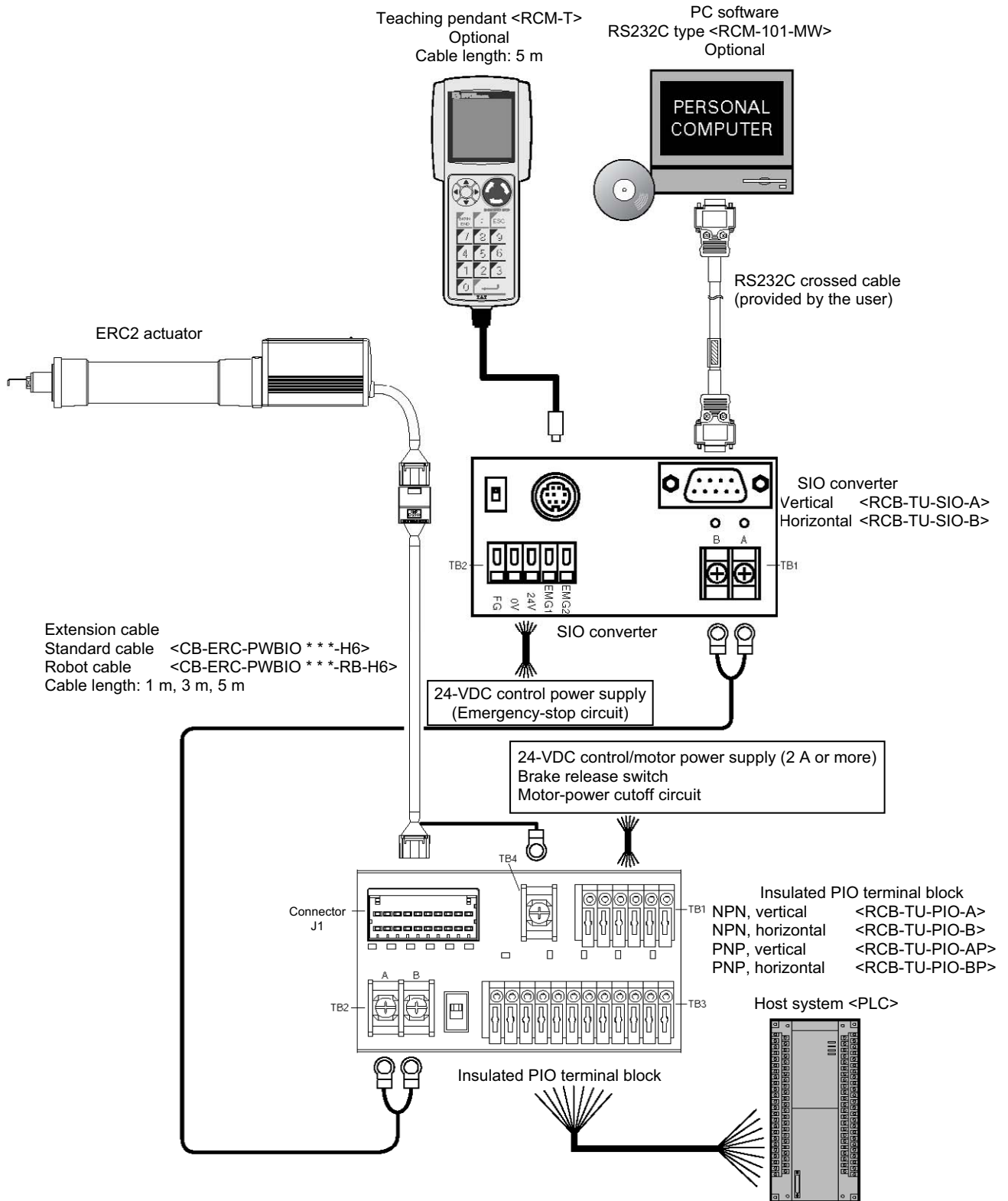

⚠ Caution: Do not connect a teaching pendant and a PC at the same time. If both are connected at the same time, a communication error (message level) will occur.

● Connection diagram

[1] When the control board is of the NPN specification [sink type]

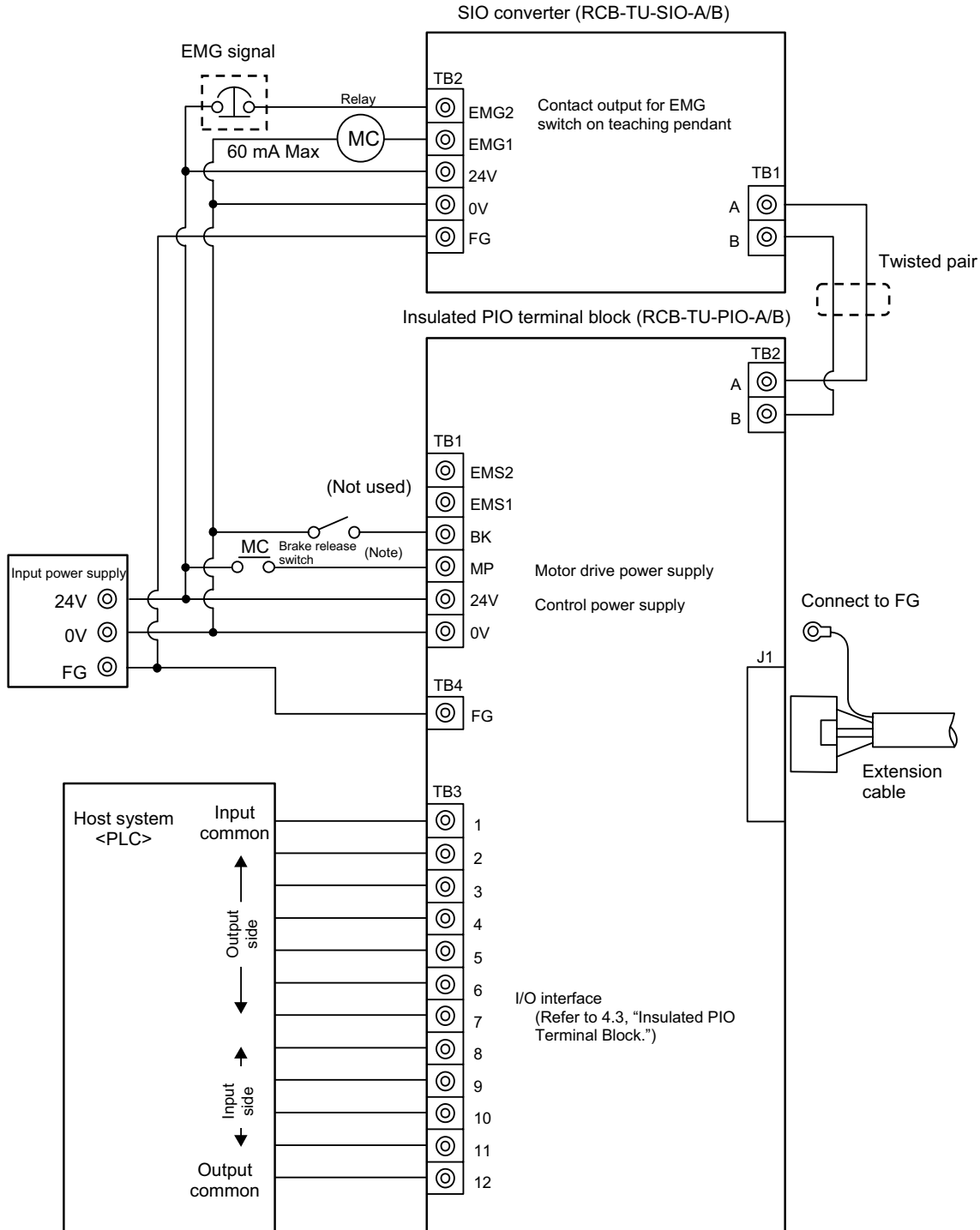

	[1] Insulate the power supply	[2] Change to PNP
Input common	24 V	0 V
Output common	0 V	24 V

(Note) To release the brake, connect a switch between the TB1-BK terminal and 0 V and turn on the switch.

[2] When the control board is of the PNP specification [source type]

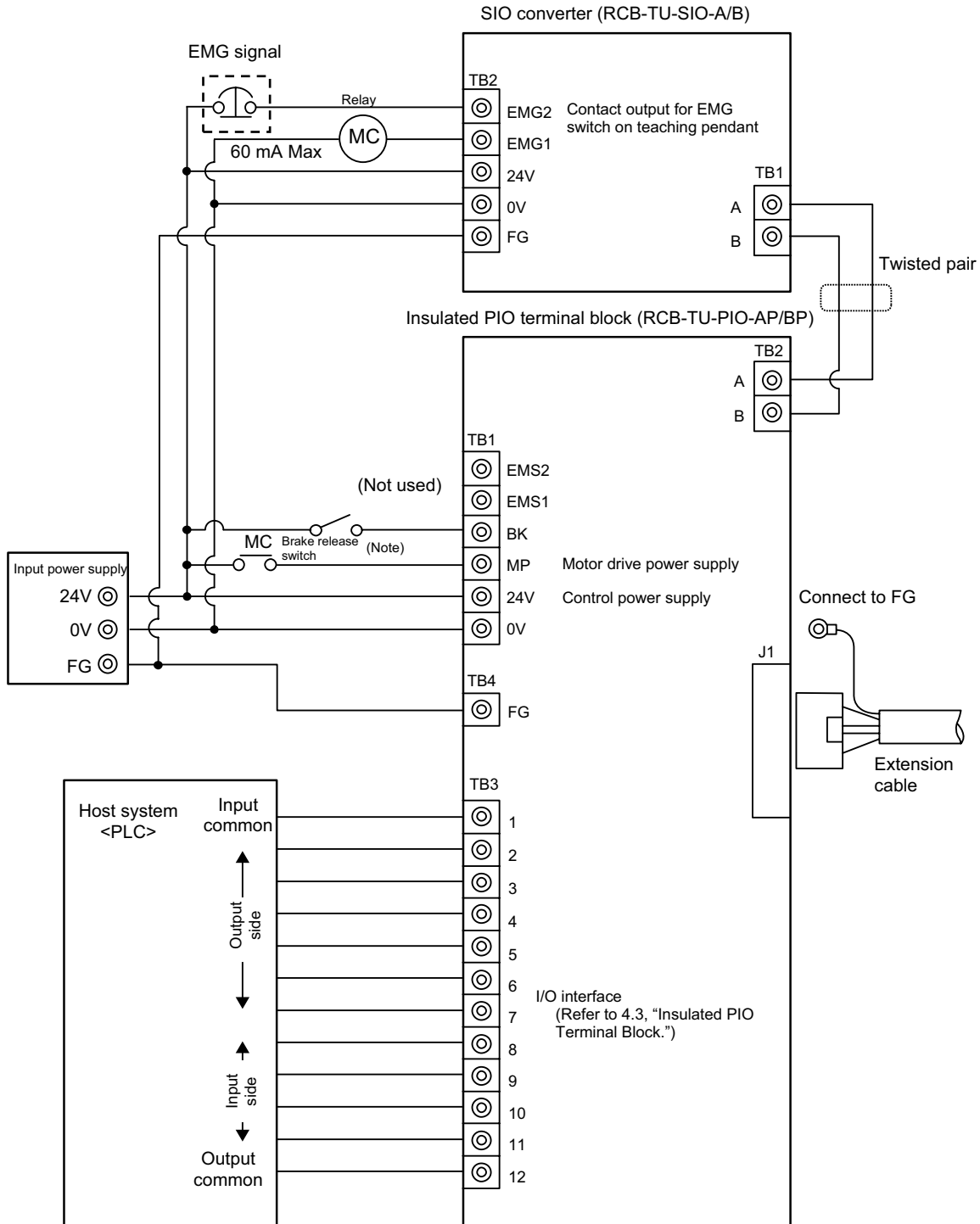

	[1] Insulate the power supply	[2] Change to NPN
Input common	0 V	24 V
Output common	24 V	0 V

(Note) To release the brake, connect a switch between the TB1-BK terminal and 24 V and turn on the switch.

3.4.1 Example of Connecting Multiple Axes Using Link Cables

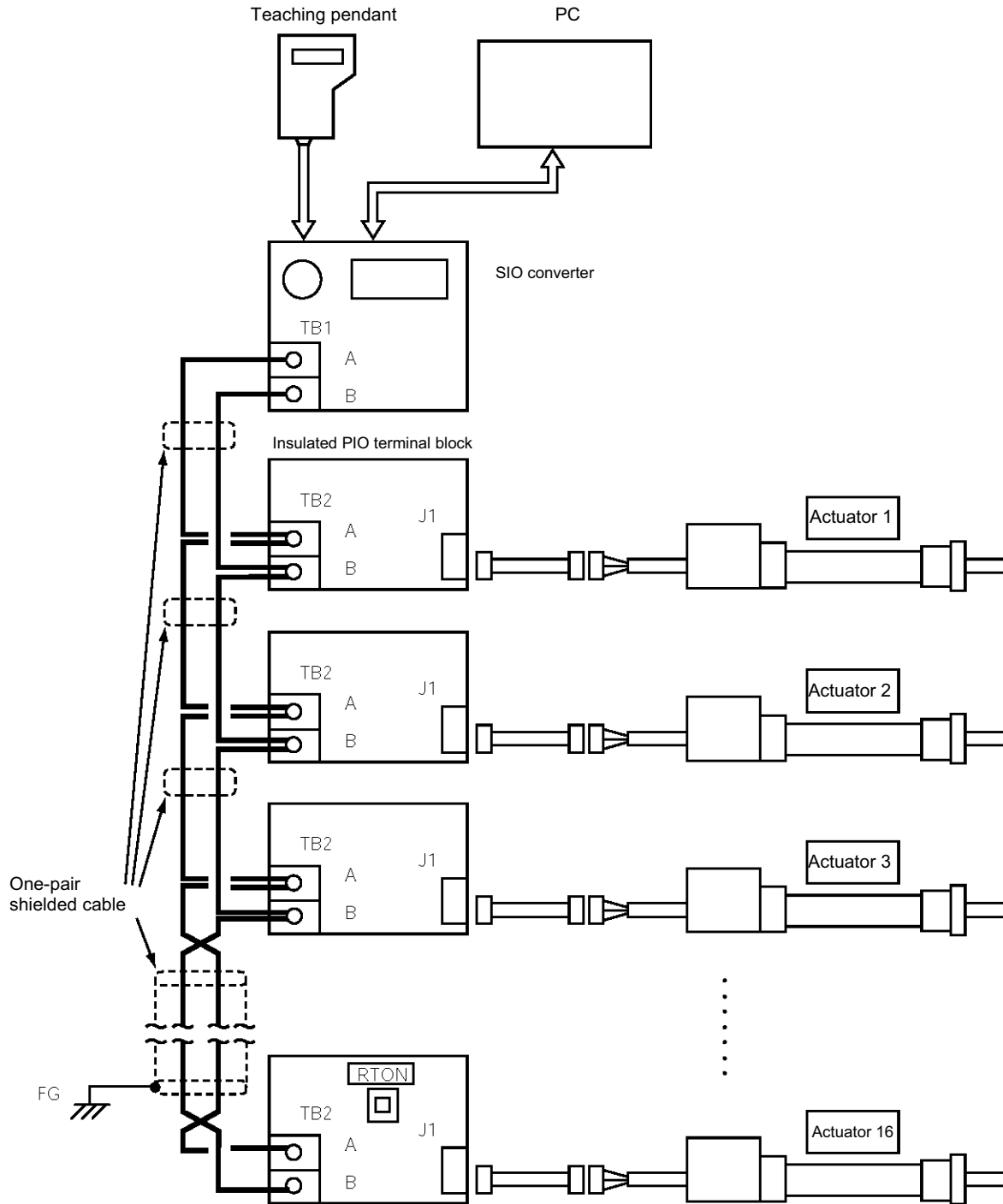

- (Note 1) Only on the last axis set the terminal-resistor connection switch to the [RTON] side.
- (Note 2) If the actuators use different power supplies, align 0 [V] on all power supplies.
- (Note 3) Connect the shielded wire of each axis to FG.
- (Note 4) If the overall length of link cable exceeds 30 m, use wire of 22AWG or larger size.

3.4.2 Address Assignment

If multiple axes are connected, a slave number must be assigned to each axis so that the host can recognize the corresponding actuator.

Assign addresses in the setting screen of the teaching pendant or PC.

- Overview of operation on the PC
 - [1] Open the main window → [2] Click **Setup (S)** → [3] Bring the cursor to **Controller Setup (C)** → [4] Bring the cursor to **Assign Address (N)** and click the mouse → [5] Enter an appropriate number in the address table.
- Overview of operation on the teaching pendant RCM-T
 - [1] Open the User Adjustment screen → [2] Use the ▼ key to bring the cursor to **Address No.** → [3] Enter an appropriate address and press the ENTER key → [4] Enter "2" under **Adjustment No.** and press the ENTER key
- Overview of operation on the simple teaching pendant RCA-E
 - [1] Open the User Adjustment screen → [2] Press the ENTER key to open the screen showing **Address No.** → [3] Enter an appropriate address and press the ENTER key → [4] Enter "2" under **Adjustment No.** and press the ENTER key

Refer to the operation manual for the teaching pendant or PC software for the specific operating procedure.

 **Caution:** In the actual process of assigning addresses, the teaching pendant or PC and the target actuator must have a one-on-one link. Therefore, disconnect the communication cables (SGA/SGB) from other axes to tentatively provide a condition where not more than one axis is connected.

3.5 Specifications of I/O Signals

3.5.1 Recognition of Input Signals

The input signals from this controller have an input time constant, in order to prevent malfunction caused by chattering, noise, etc.

Each input signal will switch the applicable setting when received continuously for 6 msec or more.

In other words, when a given input is switched from OFF to ON, the controller will recognize the ON state of the signal only after elapse of 6 msec.

The same applies to the switching of an input from ON to OFF. (Fig. 1)

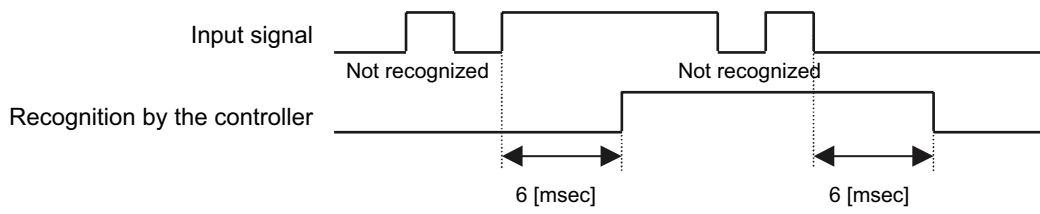
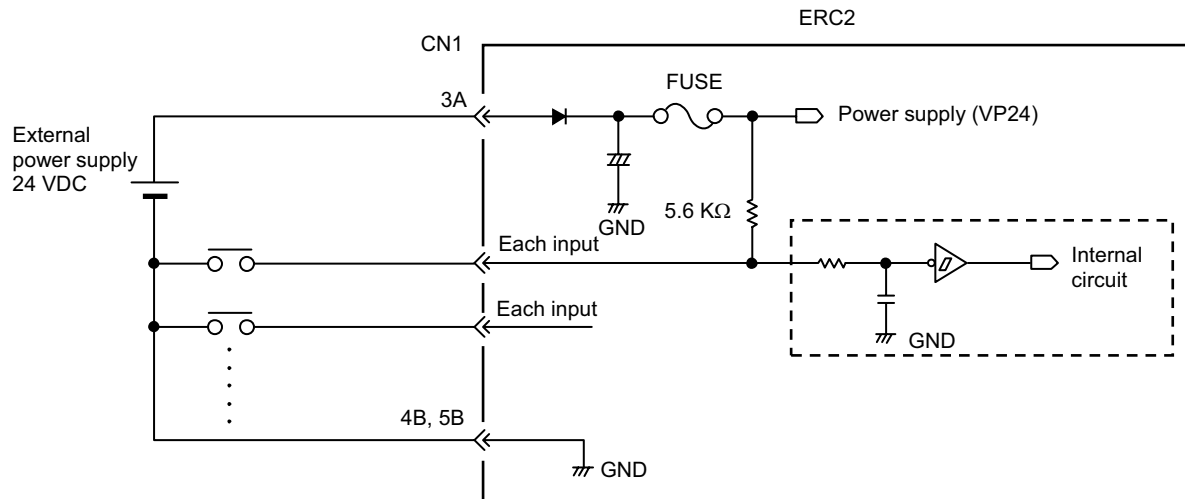

Fig. 1 Recognition of Input Signal

3.5.2 External Input Specifications

Item	Specification
Number of input points	6 points
Input voltage	24 VDC \pm 10%
Input current	4 mA/circuit
Leak current	1 mA/point or less
Operating voltage	ON voltage: 18 V min. (3.5 mA) OFF voltage: 6 V max. (1 mA)

[NPN specification]



[PNP specification]

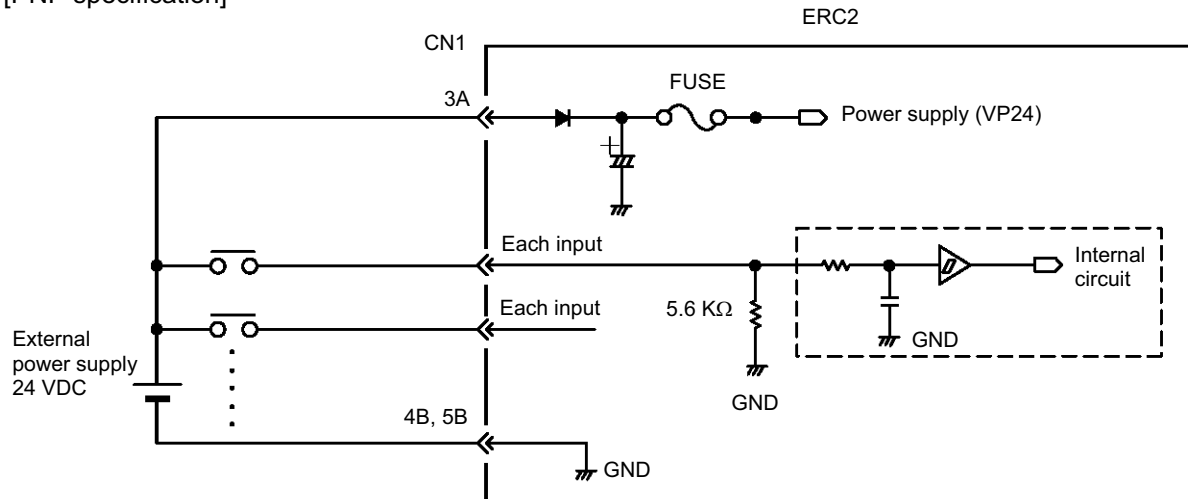

3.5.3 External Output Specifications

Item	Specification
Number of output points	4 points
Rated load voltage	24 VDC
Maximum current	60 mA/point
Residual voltage	2 V or less
Shorting/reverse-voltage protection	Fusing resistor (27Ω , 0.1 W)

[NPN specification]

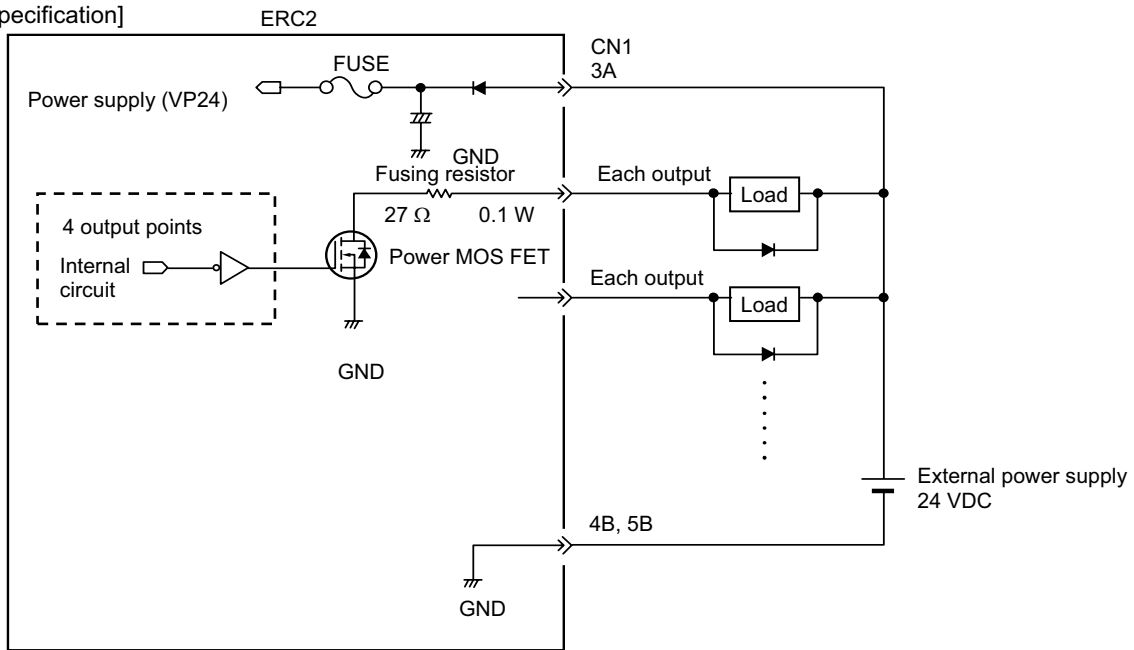

[PNP specification]

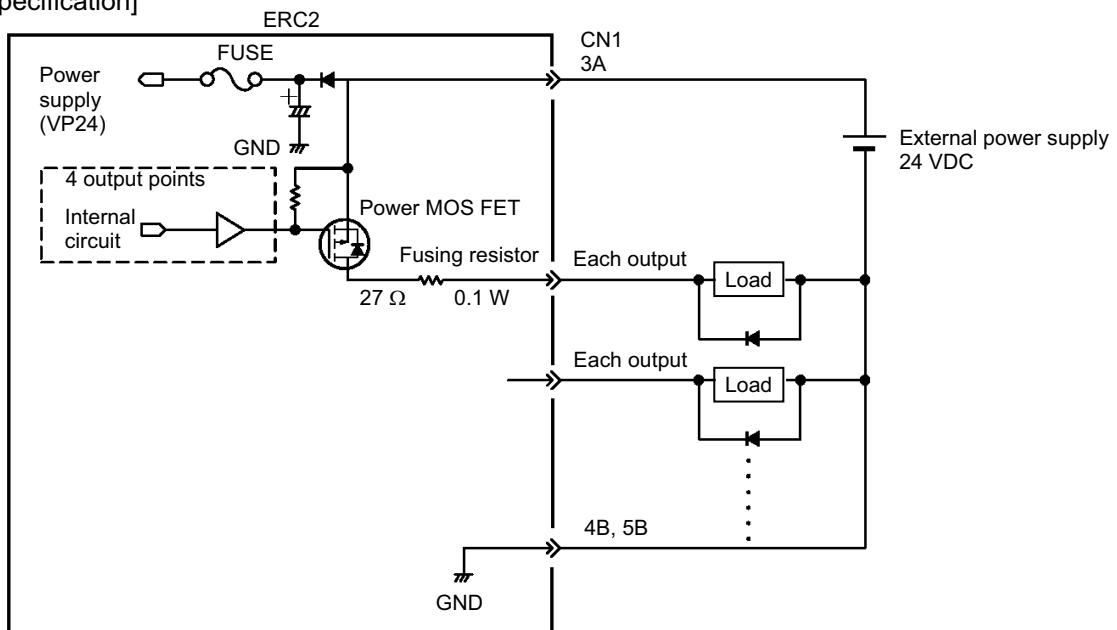

3.6 I/O Signals for PIO Pattern 1 [3 Points] (Air Cylinder)

The following description assumes that the actuator is used in place of an air cylinder. The number of positioning points is limited to three, but a direct command input and a position complete output are provided separately for the target position in line with the conventional practice of air cylinder control.

Caution: The factory setting is "8 points," so set parameter No. 25 to "1." The pause signal can be disabled in parameter No. 15.

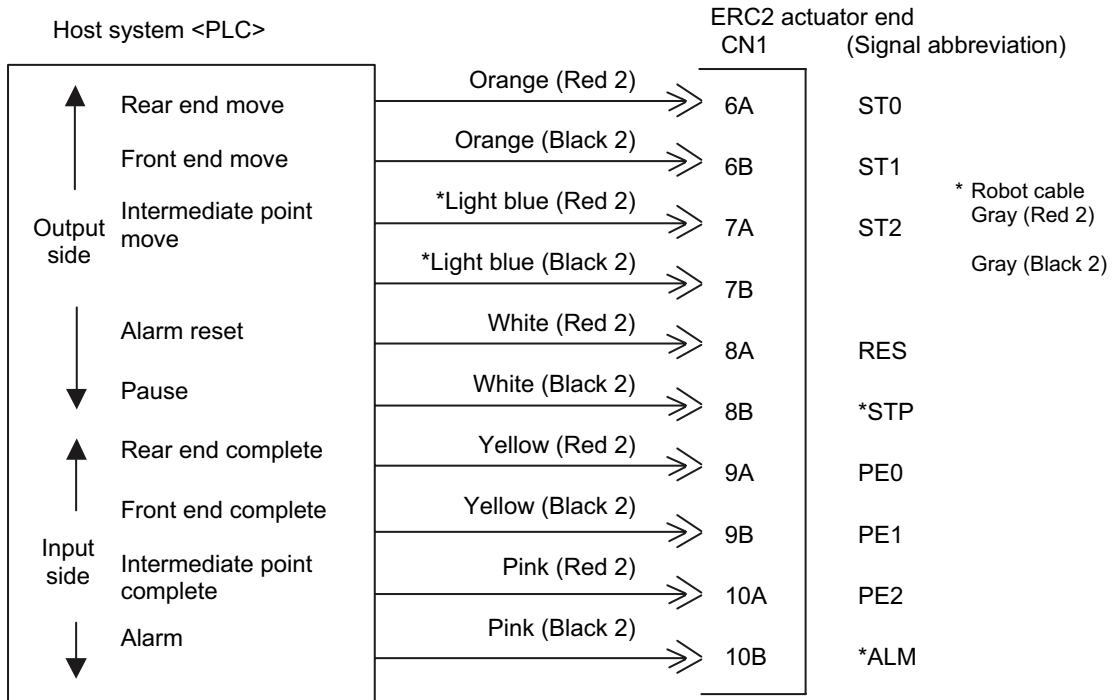

(Note) *STP and *ALM are always ON.

3.6.1 Explanation of I/O Signals

Category	Signal name	Signal abbreviation	Function overview
Input	Rear end move	ST0	The actuator starts moving to the rear end at the rise edge of the signal.
	Front end move	ST1	The actuator starts moving to the front end at the rise edge of the signal.
	Intermediate point move	ST2	The actuator starts moving to the intermediate point at the rise edge of the signal.
	*Pause	*STP	ON: The actuator can be moved, OFF: The actuator decelerates to a stop
	Alarm reset	RES	This signal resets the alarm output signal.
Output	Rear end complete	PE0	The signal turns ON when the actuator completes moving to the rear end.
	Front end complete	PE1	The signal turns ON when the actuator completes moving to the front end.
	Intermediate point complete	PE2	The signal turns ON when the actuator completes moving to the intermediate point.
	*Alarm	*ALM	This signal remains ON while the controller is operating properly, and turns OFF when an alarm generates. (Note) The signal remains ON while the motor drive power is cut off.

3.6.2 Details of Input Signals

■ Movement to each position (ST0 to ST2)

When the OFF → ON rise edge of each movement signal is detected, the actuator will move to the target position corresponding to the applicable position data.

Before executing a command using any of these signals, make sure the target position, speed and other operation data are set in the position table using a PC or teaching pendant.

Input signal	Corresponding position number	Remarks
Rear end move (ST0)	0	Set the rear end position in position No. 0.
Front end move (ST1)	1	Set the front end position in position No. 1.
Intermediate point 1 move (ST2)	2	Set the intermediate point in position No. 2.

If a movement command is issued when the first home return is not yet completed after the power was input, home return will be performed automatically to establish the coordinates first, after which the actuator will move to the target position.

■ Pause (*STP)

When this signal turns OFF while the actuator is moving, the actuator will decelerate to a stop.

The remaining movement is retained and will be resumed when the signal is turned ON again.

The *STP signal can be used for the following purposes:

- [1] Provide a low-level safety measure to stop the axis while the servo is ON, such as a sensor that detects a person approaching the system
- [2] Prevent contact with other equipment
- [3] Perform positioning based on sensor or LS detection

(Note) If the *STP signal is input while the actuator is performing home return, the movement command will be retained if the actuator is yet to contact a mechanical end. If the signal is input after the actuator has reversed upon contacting a mechanical end, home return will be performed again from the beginning.

■ Alarm reset (RES)

This signal has the following two functions:

- [1] Reset the alarm output signal (*ALM) when an alarm is present.
If an alarm has occurred, check the details of the alarm and then turn this signal ON.
The alarm will be reset upon detection of the leading edge of this signal.
(Note) Certain alarms cannot be reset using this signal. For details, refer to 9, "Troubleshooting."
- [2] If this signal is turned ON while the pause signal is OFF, the remaining movement will be cancelled.

3.6.3 Details of Output Signals

■ Completion of each position (PE0 to PE2)

These signals indicate that the target position corresponding to each movement command (ST0, ST1 or ST2) has been reached, in the same way the reed switch signal does for an air cylinder.

Output signal	Meaning of the signal
Rear end complete (PE0)	The actuator has reached and stopped at the rear end (target position set in position No. 0).
Front end complete (PE1)	The actuator has reached and stopped at the front end (target position set in position No. 1).
Intermediate point complete (PE2)	The actuator has reached and stopped at the intermediate point (target position set in position No. 2).

(Note) Although these signals remain OFF while the motor drive power is cut off, once the power is reconnected the signal will return to the ON state if the current actuator position is within the in-position band over the target position. If the actuator is positioned outside the in-position band, the signal will remain OFF.

■ Alarm (*ALM)

This signal remains ON while the controller is operating properly, and turns OFF when an alarm generates. Monitor the OFF state on PLC and provide appropriate safety measures for the entire system. Refer "9. to Troubleshooting" for alarm details.

3.7 I/O Signals for PIO Pattern 0 [8 Points]

 **Caution** The factory setting is "8 points."
The pause signal can be disabled in parameter No. 15.

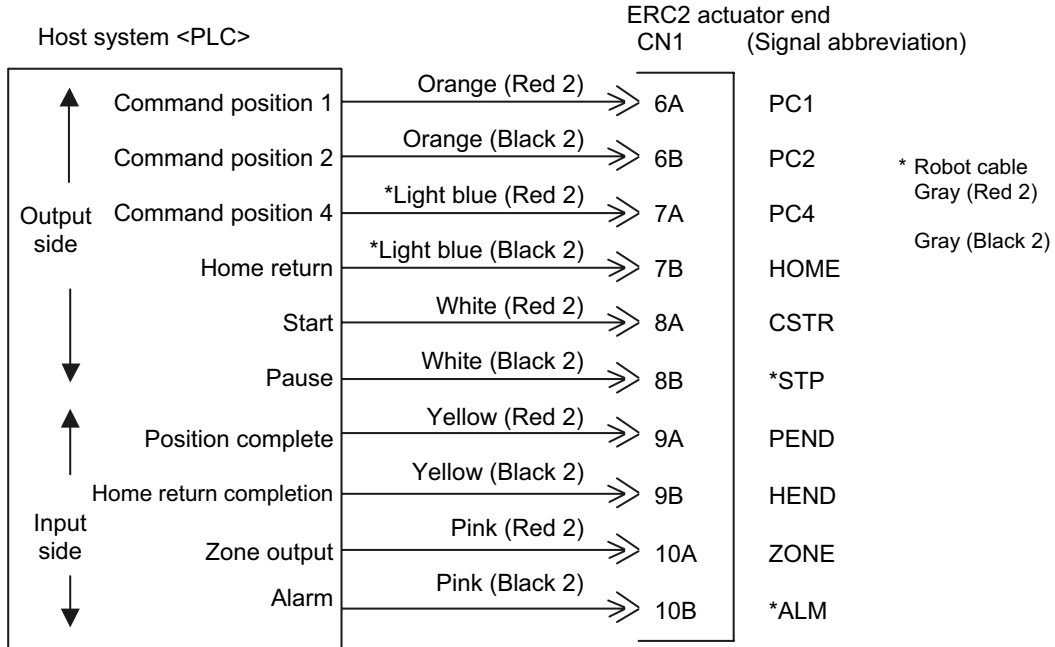

(Note) *STP and *ALM are always ON.

3.7.1 Explanation of I/O Signals

Category	Signal name	Signal abbreviation	Function overview
Input	Start	CSTR	Movement of the actuator starts at the rise edge of this signal.
	Command position number	PC1 PC2 PC4	This signal is used to input a position number that specifies movement. Be sure to set a command position number by 6 ms before the start signal (CSTR) is turned ON.
	*Pause	*STP	ON: The actuator can be moved, OFF: The actuator decelerates to a stop
	Home return	HOME	Home return starts at the rise edge of this signal.
Output	Position complete	PEND	This signal turns ON when the actuator has moved close enough to the target position and entered the in-position band. Used to determine if positioning has completed.
	Home return completion	HEND	This signal turns OFF when the power is input, and turns ON when home return completes.
	Zone	ZONE	This signal is output if the current actuator position is within the range set by the parameter upon completion of home return. Used as a limit switch for an intermediate point or a simple ruler for push & hold operation.
	*Alarm	*ALM	This signal remains ON while the controller is operating properly, and turns OFF when an alarm generates. (Note) The signal remains ON while the motor drive power is cut off.

3.7.2 Details of Input Signals

■ Start (CSTR)

When the OFF → ON rise edge of this signal is detected, the controller will read the target point number as the 3-bit binary code consisting of signals PC1 to PC4, and perform positioning to the target position specified by the corresponding position data.

Before executing a command using the start signal, make sure the target position, speed and other operation data are set in the position table using a PC or teaching pendant.

If a start command is issued when the first home return is not yet completed after the power was input, home return will be performed automatically to establish the coordinates, after which the actuator will move to the target position.

■ Command position number (PC1 to PC4)

When a movement command is effected upon OFF → ON of the start signal, the 3-bit binary code consisting of signals PC1 to PC4 will be read as the command position number.

The weight of each bit is as follows: 2^0 for PC1, 2^1 for PC2, and 2^2 for PC4. A desired position number from 0 to 7 (maximum) can be specified.

■ Pause (*STP)

When this signal turns OFF while the actuator is moving, the actuator will decelerate to a stop.

The remaining movement is retained and will be resumed when the signal is turned ON again.

The *STP signal can be used for the following purposes:

- [1] Provide a low-level safety measure to stop the axis while the servo is ON, such as a sensor that detects a person approaching the system
- [2] Prevent contact with other equipment
- [3] Perform positioning based on sensor or LS detection

(Note) If the *STP signal is input while the actuator is performing home return, the movement command will be retained if the actuator is yet to contact a mechanical end. If the signal is input after the actuator has reversed upon contacting a mechanical end, home return will be performed again from the beginning.

■ Home return (HOME)

The controller will start home return operation upon detection of an OFF → ON edge of this signal.

When the home return is complete, the HEND signal will be output. The HOME signal can be input as many times as required.

(Note) The HOME signal is not an absolute requirement, because even if home return has not yet been performed after the power was input, the controller will automatically perform home return operation before positioning to the target position.

3.7.3 Details of Output Signals

■ Position complete (PEND)

This signal indicates that the target position was reached and positioning has completed.

When the controller becomes ready after the power was input and the servo has turned ON, this signal will turn ON if the position deviation is within the in-position band.

Then, when a movement command is issued by turning ON the start signal, the PEND signal will turn OFF. It will turn ON again when the deviation from the target position falls within the in-position band.

Once turned ON, the PEND signal will not turn OFF even when the position deviation subsequently exceeds the in-position range.

(Note) If the start signal remains ON, the PEND signal will not turn OFF even when the deviation from the target position falls within the in-position range: it will turn ON when the start signal turns OFF.

Even when the motor is stopped, the PEND signal will remain OFF if the pause signal is input or the servo is OFF.

■ Home return completion (HEND)

This signal is OFF immediately after the power is input, and turns ON in either of the following two conditions:

[1] Home return operation has completed with respect to the first movement command issued with the start signal.

[2] Home return operation has completed following an input of the home return signal.

Once turned ON, this signal will not turn OFF until the input power is cut off or the home return signal is input again.

The HEND signal can be used for the following purposes:

[1] Check prior to establishing the home if movement toward the home direction is permitted, in cases where an obstacle is located in the direction of the home

[2] As a condition for enabling the zone output signal

■ Zone (ZONE)

Use a ZONE signal as a limit switch at an intermediate point or as a simple ruler.

This signal will turn ON when the current position is inside the range specified by parameter Nos. 1 and 2, and turn OFF if the current position is outside this range.

(Note) The ZONE signal is enabled after the coordinate system is established following a completion of home return. It will not be output simply by turning on the power.

As long as home return has completed, the ZONE signal remains enabled while the motor drive power is cut off.

■ Alarm (*ALM)

This signal remains ON while the controller is operating properly, and turns OFF when an alarm has generated.

Provide an appropriate safety measure for the entire system by allowing the PLC to monitor the OFF status of this signal.

For details of alarms, refer to 9, "Troubleshooting."

(Reference) Output Signal Changes in Each Mode

Mode classification	PEND	HEND
Actuator is stopped with the servo ON after the power was input	ON	OFF
Home return is in progress following an input of the home return signal	OFF	OFF
Home return has completed following an input of the home return signal	ON	ON
Actuator is moving in the positioning/push & hold mode	OFF	ON
Actuator is paused in the positioning/push & hold mode	OFF	ON
Positioning has completed in the positioning mode	ON	ON
Actuator has stopped after contacting the work part in the push & hold mode	ON	ON
Actuator has stopped after missing the work part (no work part) in the push & hold mode	OFF	ON
Motor drive power is cut off after home return	OFF	ON

(Note) Use PEND to determine whether the actuator has stopped after contacting the work part or missing the work part in the push & hold mode.

3.8 I/O Signals for PIO Pattern 2 [16 Points] (Setting by Zone Boundary Parameters)

Caution The factory setting is "8 points," so set parameter No. 25 to "2."
The pause signal can be disabled in parameter No. 15.

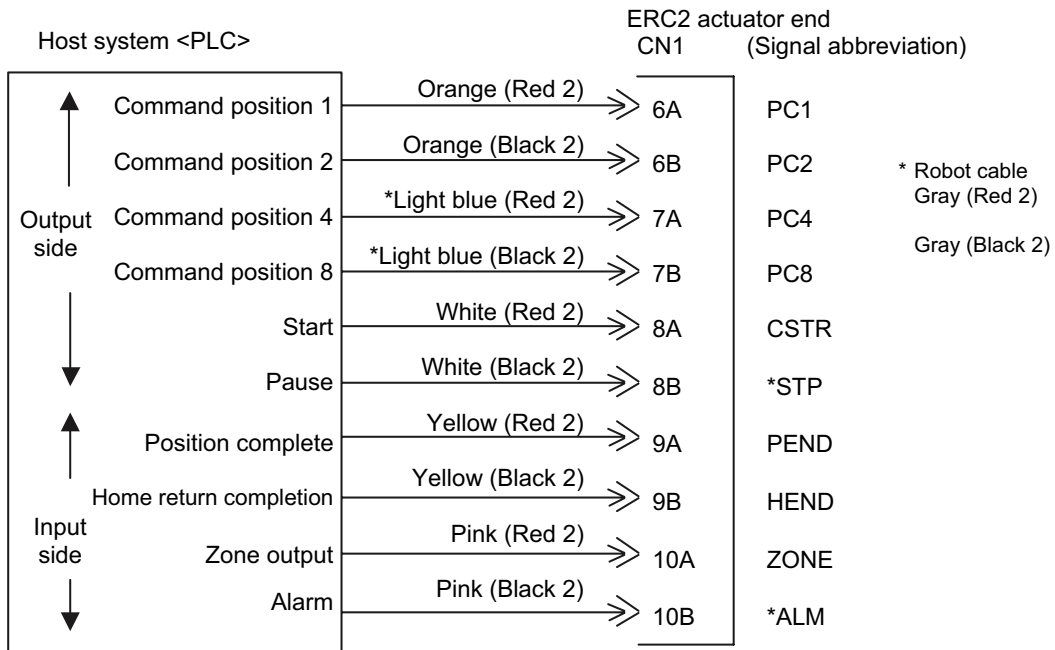

(Note) *STP and *ALM are always ON.

3.8.1 Explanation of I/O Signals

The following explains the signals used in the "8 points" and "16 points" patterns.

Category	Signal name	Signal abbreviation	Function overview
Input	Start	CSTR	Movement of the actuator starts at the rise edge of this signal.
	Command position number	PC1 PC2 PC4 PC8	This signal is used to input a position number that specifies movement. Be sure to set a command position number by 6 ms before the start signal (CSTR) is turned ON.
	*Pause	*STP	ON: The actuator can be moved, OFF: The actuator decelerates to a stop
Output	Position complete	PEND	This signal turns ON when the actuator has moved close enough to the target position and entered the in-position band. Used to determine if positioning has completed.
	Home return completion	HEND	This signal turns OFF when the power is input, and turns ON when home return completes.
	Zone	ZONE	This signal is output if the current actuator position is within the range set by the parameter upon completion of home return. Used as a limit switch for an intermediate point or a simple ruler for push & hold operation.
	*Alarm	*ALM	This signal remains ON while the controller is operating properly, and turns OFF when an alarm generates. (Note) The signal remains ON while the motor drive power is cut off.

3.8.2 Details of Input Signals

■ Start (CSTR)

When the OFF → ON rise edge of this signal is detected, the controller will read the target point number as the 4-bit binary code consisting of signals PC1 to PC8, and perform positioning to the target position specified by the corresponding position data.

Before executing a command using the start signal, make sure the target position, speed and other operation data are set in the position table using a PC or teaching pendant.

If a start command is issued when the first home return is not yet completed after the power was input, home return will be performed automatically to establish the coordinates, after which the actuator will move to the target position.

■ Command position number (PC1 to PC8)

When a movement command is effected upon OFF → ON of the start signal, the 4-bit binary code consisting of signals PC1 to PC8 will be read as the command position number.

The weight of each bit is as follows: 2^0 for PC1, 2^1 for PC2, 2^2 for PC4, and 2^3 for PC8. A desired position number from 0 to 15 (maximum) can be specified.

■ Pause (*STP)

When this signal turns OFF while the actuator is moving, the actuator will decelerate to a stop.

The remaining movement is retained and will be resumed when the signal is turned ON again.

The *STP signal can be used for the following purposes:

- [1] Provide a low-level safety measure to stop the axis while the servo is ON, such as a sensor that detects a person approaching the system
- [2] Prevent contact with other equipment
- [3] Perform positioning based on sensor or LS detection

(Note) If the *STP signal is input while the actuator is performing home return, the movement command will be retained if the actuator is yet to contact a mechanical end. If the signal is input after the actuator has reversed upon contacting a mechanical end, home return will be performed again from the beginning.

3.8.3 Details of Output Signals

■ Position complete (PEND)

This signal indicates that the target position was reached and positioning has completed.

When the controller becomes ready after the power was input and the servo has turned ON, this signal will turn ON if the position deviation is within the in-position band.

Then, when a movement command is issued by turning ON the start signal, the PEND signal will turn OFF. It will turn ON again when the deviation from the target position falls within the in-position band.

Once turned ON, the PEND signal will not turn OFF even when the position deviation subsequently exceeds the in-position range.

(Note) If the start signal remains ON, the PEND signal will not turn OFF even when the deviation from the target position falls within the in-position range: it will turn ON when the start signal turns OFF.

Even when the motor is stopped, the PEND signal will remain OFF if the pause signal is input or the servo is OFF.

■ Home return completion (HEND)

This signal is OFF immediately after the power is input, and turns ON in either of the following two conditions:

[1] Home return operation has completed with respect to the first movement command issued with the start signal.

[2] Home return operation has completed following an input of the home return signal.

Once turned ON, this signal will not turn OFF until the input power is cut off or the home return signal is input again.

The HEND signal can be used for the following purposes:

[1] Check prior to establishing the home if movement toward the home direction is permitted, in cases where an obstacle is located in the direction of the home

[2] Use as a condition for enabling the zone output signal

■ Zone (ZONE)

Use a ZONE signal as a limit switch at an intermediate point or as a simple ruler.

This signal will turn ON when the current position is inside the range specified by parameter Nos. 1 and 2, and turn OFF if the current position is outside this range.

(Note) The ZONE signal is enabled after the coordinate system is established following a completion of home return. It will not be output simply by turning on the power.

As long as home return has completed, the ZONE signal remains enabled while the motor drive power is cut off.

■ Alarm (*ALM)

This signal remains ON while the controller is operating properly, and turns OFF when an alarm has generated.

Provide an appropriate safety measure for the entire system by allowing the PLC to monitor the OFF status of this signal.

For details of alarms, refer to 9, "Troubleshooting."

(Reference) Output Signal Changes in Each Mode

Mode classification	PEND	HEND
Actuator is stopped with the servo ON after the power was input	ON	OFF
Actuator is moving in the positioning/push & hold mode	OFF	ON
Actuator is paused in the positioning/push & hold mode	OFF	ON
Positioning has completed in the positioning mode	ON	ON
Actuator has stopped after contacting the work part in the push & hold mode	ON	ON
Actuator has stopped after missing the work part (no work part) in the push & hold mode	OFF	ON
Motor drive power is cut off after home return	OFF	ON

(Note) Use PEND to determine whether the actuator has stopped after contacting the work part or missing the work part in the push & hold mode.

3.9 I/O Signals for PIO Pattern 3 [16 Points] (Setting in Zone Fields in the Position Table)

Note The factory setting is "8 points," so set parameter No. 25 to "3."
The pause signal can be disabled in parameter No. 15.

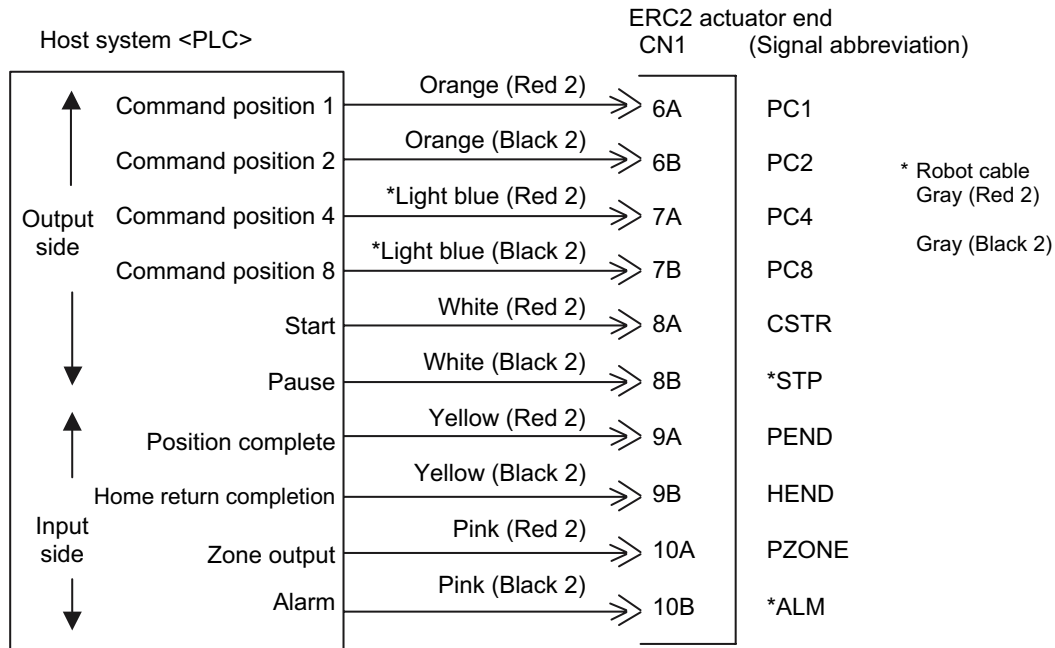

(Note) *STP and *ALM are always ON.

3.9.1 Explanation of I/O Signals

Category	Signal name	Signal abbreviation	Function overview
Input	Start	CSTR	Movement of the actuator starts at the rise edge of this signal.
	Command position number	PC1 PC2 PC4 PC8	This signal is used to input a position number that specifies movement. Be sure to set a command position number by 6 ms before the start signal (CSTR) is turned ON.
	*Pause	*STP	ON: The actuator can be moved, OFF: The actuator decelerates to a stop
Output	Position complete	PEND	This signal turns ON when the actuator has moved close enough to the target position and entered the in-position band. Used to determine if positioning has completed.
	Home return completion	HEND	This signal turns OFF when the power is input, and turns ON when home return completes.
	Zone	PZONE	This signal is output if, upon completion of home return, the current actuator position is within the range set by the "Zone" fields for the applicable command position number in the position table. It is used as a limit switch at an intermediate point or as a simple ruler for push & hold operation.
	*Alarm	*ALM	This signal remains ON while the controller is operating properly, and turns OFF when an alarm generates. (Note) The signal remains ON while the motor drive power is cut off.

3.9.2 Details of Input Signals

■ Start (CSTR)

When the OFF → ON rise edge of this signal is detected, the controller will read the target point number as the 4-bit binary code consisting of signals PC1 to PC8, and perform positioning to the target position specified by the corresponding position data.

Before executing a command using the start signal, make sure the target position, speed and other operation data are set in the position table using a PC or teaching pendant.

If a start command is issued when the first home return is not yet completed after the power was input, home return will be performed automatically to establish the coordinates, after which the actuator will move to the target position.

■ Command position number (PC1 to PC8)

When a movement command is effected upon OFF → ON of the start signal, the 4-bit binary code consisting of signals PC1 to PC8 will be read as the command position number.

The weight of each bit is as follows: 2^0 for PC1, 2^1 for PC2, 2^2 for PC4, and 2^3 for PC8. A desired position number from 0 to 15 (maximum) can be specified.

■ Pause (*STP)

When this signal turns OFF while the actuator is moving, the actuator will decelerate to a stop.

The remaining movement is retained and will be resumed when the signal is turned ON again.

The *STP signal can be used for the following purposes:

- [1] Provide a low-level safety measure to stop the axis while the servo is ON, such as a sensor that detects a person approaching the system
- [2] Prevent contact with other equipment
- [3] Perform positioning based on sensor or LS detection

(Note) If the *STP signal is input while the actuator is performing home return, the movement command will be retained if the actuator is yet to contact a mechanical end. If the signal is input after the actuator has reversed upon contacting a mechanical end, home return will be performed again from the beginning.

3.9.3 Details of Output Signals

■ Position complete (PEND)

This signal indicates that the target position was reached and positioning has completed.

When the controller becomes ready after the power was input and the servo has turned ON, this signal will turn ON if the position deviation is within the in-position band.

Then, when a movement command is issued by turning ON the start signal, the PEND signal will turn OFF. It will turn ON again when the deviation from the target position falls within the in-position band.

Once turned ON, the PEND signal will not turn OFF even when the position deviation subsequently exceeds the in-position range.

(Note) If the start signal remains ON, the PEND signal will not turn OFF even when the deviation from the target position falls within the in-position range: it will turn ON when the start signal turns OFF.

Even when the motor is stopped, the PEND signal will remain OFF if the pause signal is input or the servo is OFF.

■ Home return completion (HEND)

This signal is OFF immediately after the power is input, and turns ON in either of the following two conditions:

[1] Home return operation has completed with respect to the first movement command issued with the start signal.

[2] Home return operation has completed following an input of the home return signal.

Once turned ON, this signal will not turn OFF until the input power is cut off or the home return signal is input again.

The HEND signal can be used for the following purposes:

[1] Check prior to establishing the home if movement toward the home direction is permitted, in cases where an obstacle is located in the direction of the home

[2] As a condition for enabling the zone output signal

■ Zone (PZONE)

Use the PZONE signal as a limit switch at an intermediate point or as a simple ruler.

This signal turns ON when the current actuator position is within the range set by the "Zone" fields for the applicable command position number in the position table, and turns OFF if the current position is outside this range.

(Note) The PZONE signal is enabled only after a position movement command has been accepted. The signal is not output simply by turning on the power.

As long as home return has completed, the PZONE signal remains enabled even while the motor drive power is cut off.

■ Alarm (*ALM)

This signal remains ON while the controller is operating properly, and turns OFF when an alarm has generated.

Provide an appropriate safety measure for the entire system by allowing the PLC to monitor the OFF status of this signal.

For details of alarms, refer to 9, "Troubleshooting."

(Reference) Output Signal Changes in Each Mode

Mode classification	PEND	HEND
Actuator is stopped with the servo ON after the power was input	ON	OFF
Actuator is moving in the positioning/push & hold mode	OFF	ON
Actuator is paused in the positioning/push & hold mode	OFF	ON
Positioning has completed in the positioning mode	ON	ON
Actuator has stopped after contacting the work part in the push & hold mode	ON	ON
Actuator has stopped after missing the work part (no work part) in the push & hold mode	OFF	ON
Motor drive power is cut off after home return	OFF	ON

(Note) Use PEND to determine whether the actuator has stopped after contacting the work part or missing the work part in the push & hold mode.

3.10 Emergency-Stop Circuit

Examples of internal circuit and recommended circuit are shown below.

Caution For auxiliary relays, use relays with a diode for absorbing coil surge.

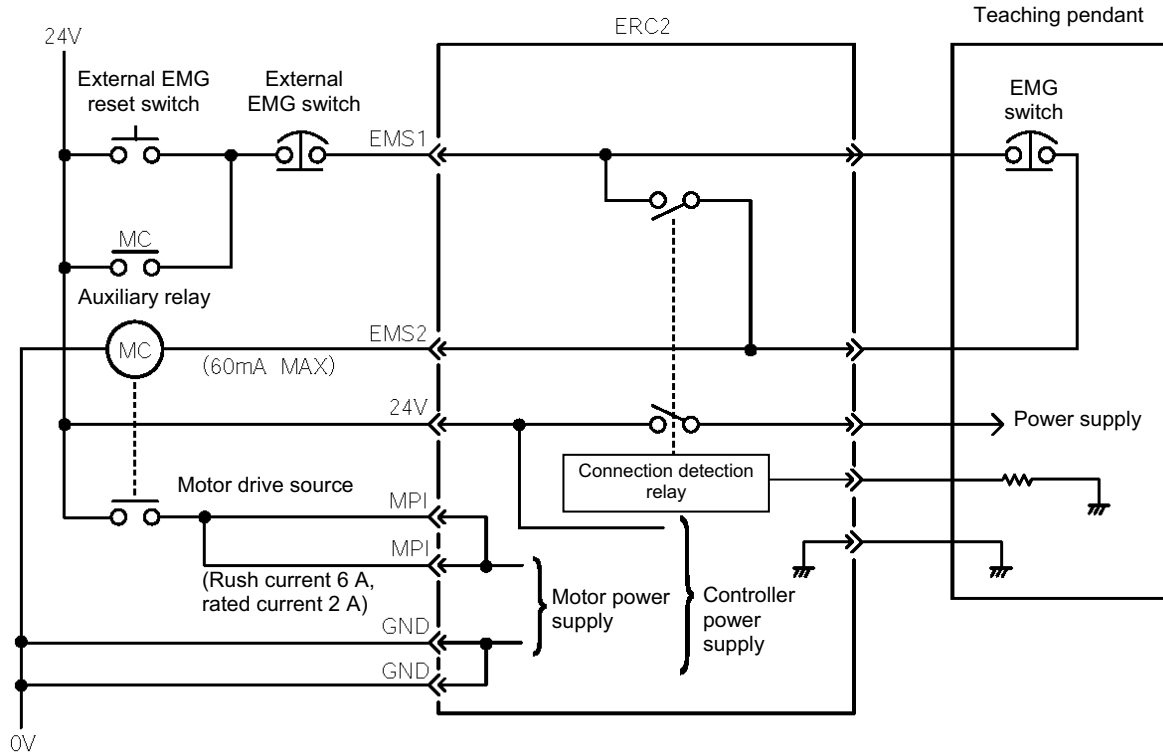

[Reference] Recommended relay brands are specified in the table below. Use this table as a reference when selecting relays for your system.

Manufacturer	Product name
Omron	LY Series (with diode for absorbing surge current in coil)
Matsushita Electric Works	HC Relay Series (with diode for absorbing surge current in coil)

For the detailed specifications of each product, check the specification sheet issued by the applicable manufacturer.

- Example of multi-axes circuit allowing each axis to be connected/disconnected to the teaching pendant

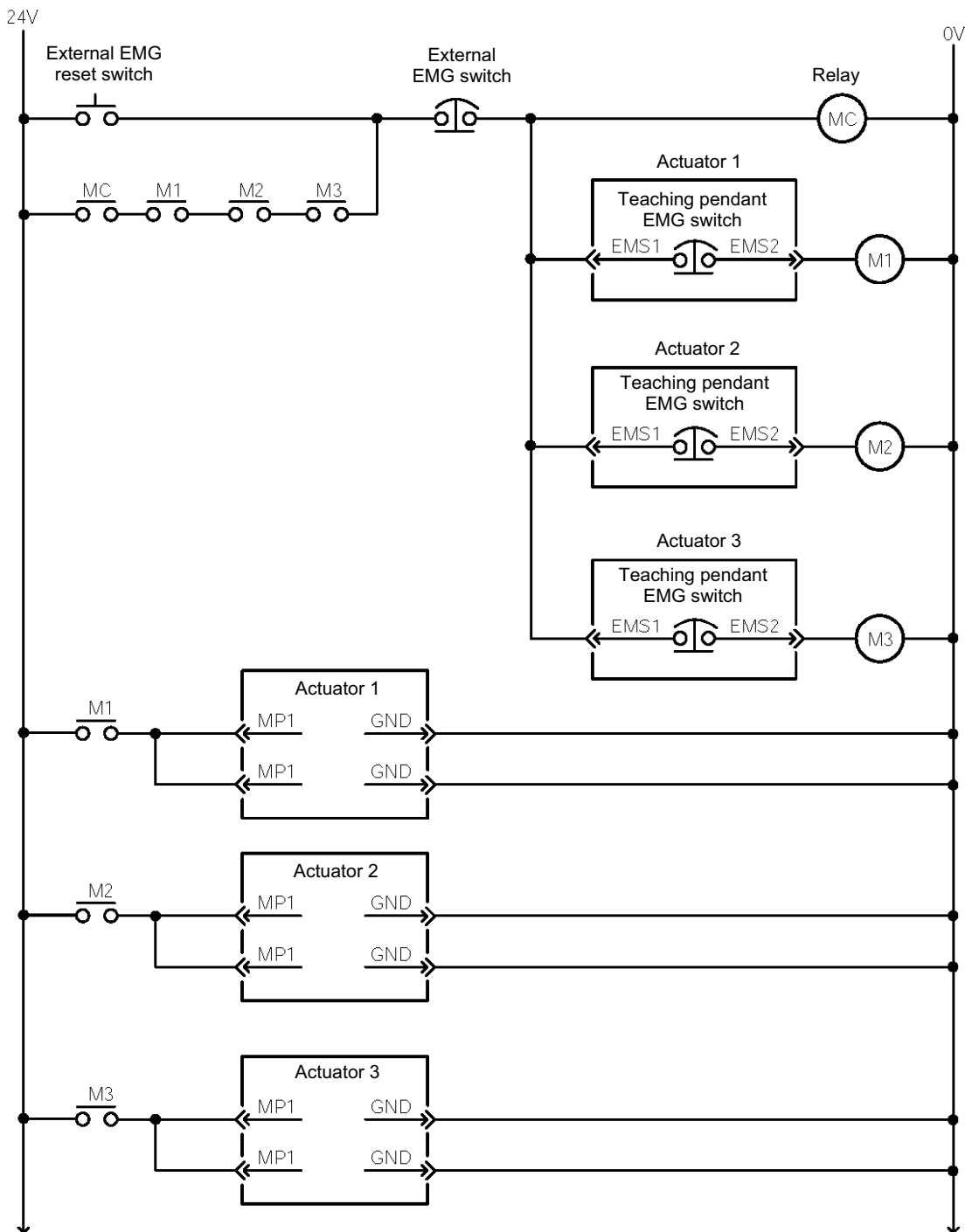

3.11 Extension Cable

- No connector on the counter-actuator end (When connecting the actuator directly to a host system)

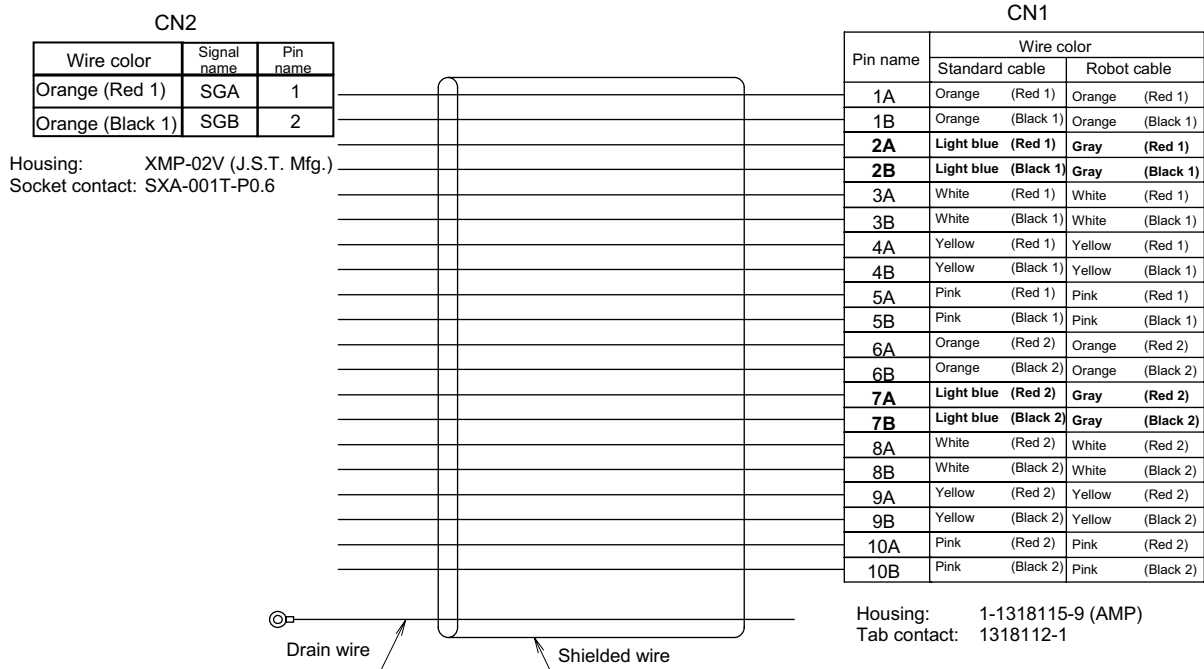
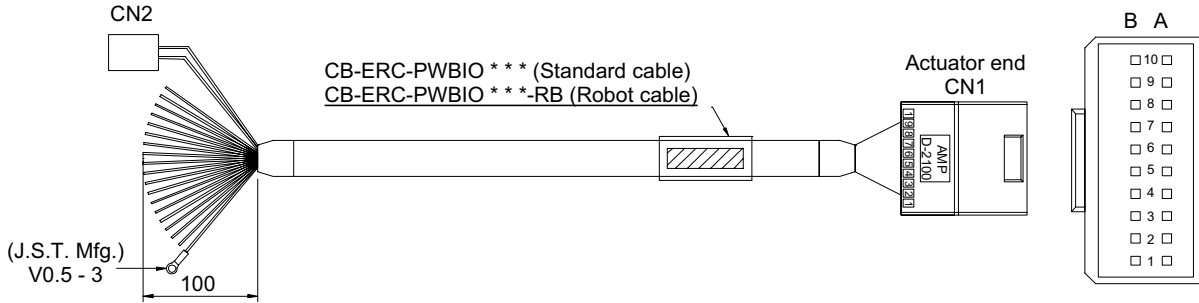

(Supplied cables to be connected to CN2)

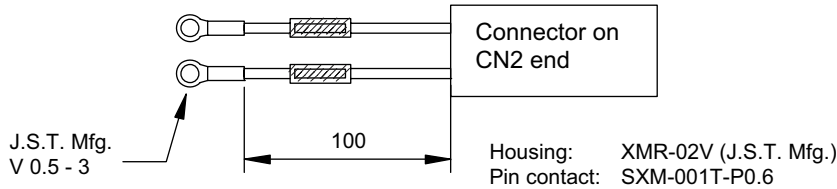

Wire color	Signal name	Pin name
Orange (Red 1)	SGA	1
Orange (Black 1)	SGB	2

(Note) Connecting 24V to the SGA/SGB serial-communication lines will cause a breakdown. To prevent miswiring, a two-pin connector is installed at the ends of the applicable lines. If multiple axes are linked, connect these supplied cables to the CN2 connector and extend as required, or cut them off at the base of the CN2 connector and install crimp terminals directly.

- Connectors on both ends (When using an isolated PIO terminal block)

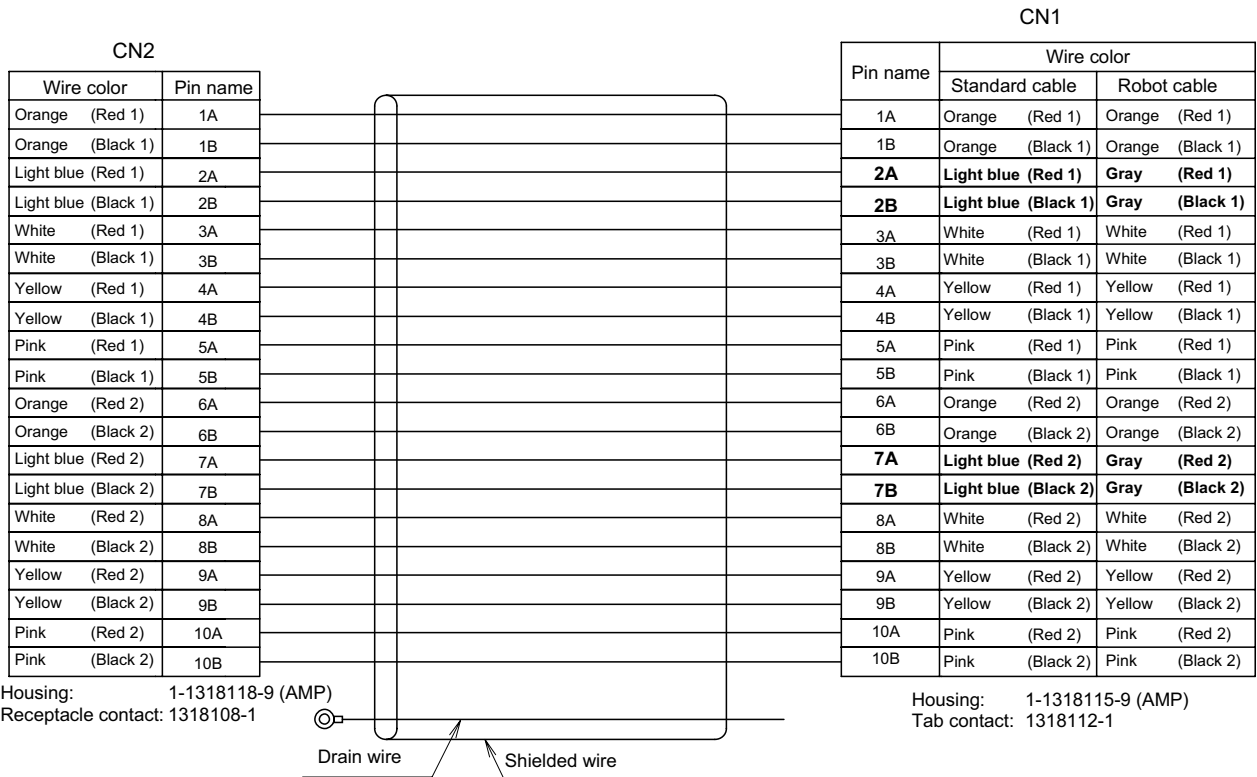
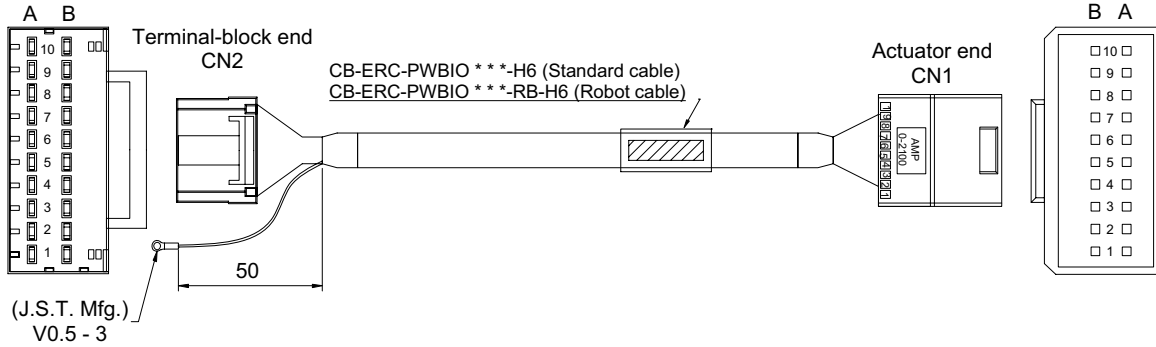

4. Electrical Specifications

4.1 Controller

Specification item		Description
Number of controlled axes		1 axis/unit
Supply voltage		24 VDC \pm 10%
Supply current		2 A max.
Control method		Weak field-magnet vector control (patent pending)
Positioning command		Position number specification
Position number		Maximum 16 points
Backup memory		Position number data and parameters are saved in nonvolatile memory. Serial E ² PROM can be rewritten 100,000 times.
PIO		6 dedicated inputs/4 dedicated outputs
LED indicator		Servo ON (green)/Alarm (red)
Communication		RS485 1 channel (terminated externally)
Electromagnetic brake Release		The user must provide a selector switch. (Current consumption: 0.15 A max.)
Extension cable length		10 m or less
Isolation strength		500 VDC, 10 M Ω
Environment	Operating temperature	0 to 40°C
	Operating humidity	85%RH or less (non-condensing)
	Operating environment	No contact with corrosive gases.
	Storage temperature	-10 to 65°C
	Storage humidity	90%RH or less (non-condensing)
	Vibration resistance	10 to 57 Hz in XYZ directions / Pulsating amplitude: 0.035 mm (continuous), 0.075 mm (intermittent)
	Protection class	IP20
Weight		Approx. 32 g
External dimensions		109 W x 40 D (mm), printed circuit board

4.2 SIO Converter (Optional)

Model number: RCB-TU-SIO-A (Vertical installation)
RCB-TU-SIO-B (Horizontal installation)

This unit is required if any of the following conditions applies:

- [1] The actuator's rear cover cannot be reached and therefore the teaching pendant or PC cannot be connected.
- [2] Want to execute movement operation or parameter edit for all axes when multiple axes are connected to the single equipment.

● Explanation of functions

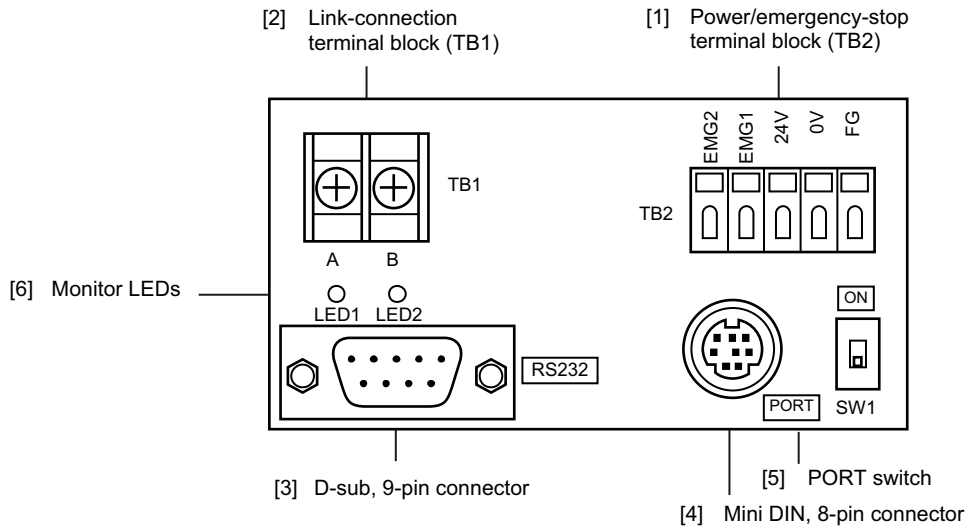

[1] Power/emergency-stop terminal block (TB2)

EMG1, EMG2	Provide a contact output for the emergency-stop switch on the teaching pendant (RCA-T/E). EMG1 and EMG2 connect to the emergency-stop switch on the teaching pendant when the PORT switch is ON, or are shorted when the PORT switch is OFF.						
24V	These terminals comprise an interlock with a safety circuit provided by the user.						
0V	Positive side of the 24-V power supply						
FG	<table border="0"> <tr> <td style="font-size: 2em;">{</td> <td>Power supply for the teaching pendant and conversion circuit</td> <td style="font-size: 2em;">}</td> </tr> <tr> <td></td> <td>Current consumption: 0.1 A max.</td> <td></td> </tr> </table>	{	Power supply for the teaching pendant and conversion circuit	}		Current consumption: 0.1 A max.	
{	Power supply for the teaching pendant and conversion circuit	}					
	Current consumption: 0.1 A max.						
	Negative side of the 24-V power supply						
	FG of the 24-V power supply						

[2] Link-connection terminal block (TB1)

A connection port for linking the controller.

"A" on the left side connects to SGA (wire color: orange/red 1) in the extension cable or "A" on the isolated PIO terminal block TB2.

"B" on the right side connects to SGB (wire color: orange/black 1) in the extension cable or "B" on the isolated PIO terminal block TB2.

(Note) Be sure to use twisted pair wires for the above two lines (SGA/SGB).

[3] D-sub, 9-pin connector

A connection port with the host PC or PLC's communication module.

[4] Mini DIN, 8-pin connector

A connection port with the teaching pendant.

- [5] PORT switch
A switch for enabling/disabling the teaching pendant.
Set the switch to ON when a teaching pendant is used, or OFF when teaching pendant is not used.
- [6] Monitor LEDs
LED1 --- Lit when the controller is transmitting
LED2 --- Lit when the RS232 is transmitting

(Reference) Connection drawing of a RS232C crossed cable

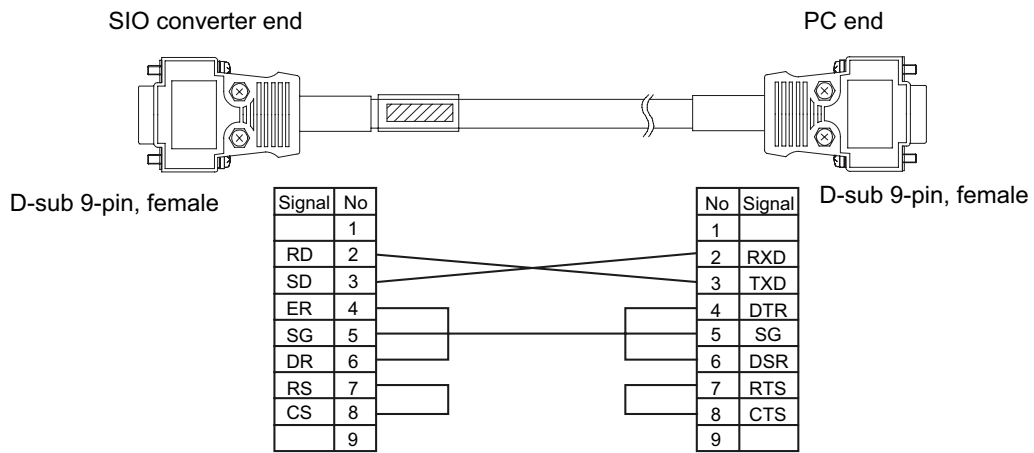

4.3 Isolated PIO Terminal Block (Optional)

Model number: RCB-TU-PIO-A (Combined with a NPN control board: Vertical installation)
 RCB-TU-PIO-B (Combined with a NPN control board: Horizontal installation)
 RCB-TU-PIO-AP (Combined with a PNP control board: Vertical installation)
 RCB-TU-PIO-BP (Combined with a PNP control board: Horizontal installation)

This unit is required if either of the following conditions applies:

- [1] Want to insulate the control power supply from the PIO power supply.
- [2] Want to change the I/O logic of the control board.
 - Control board: NPN (sink type) → Host system: PNP (source type)
 - Control board: PNP (source type) → Host system: NPN (sink type)

● Explanation of functions

[External view of RCB-TU-PIO-A/AP/B/BP]

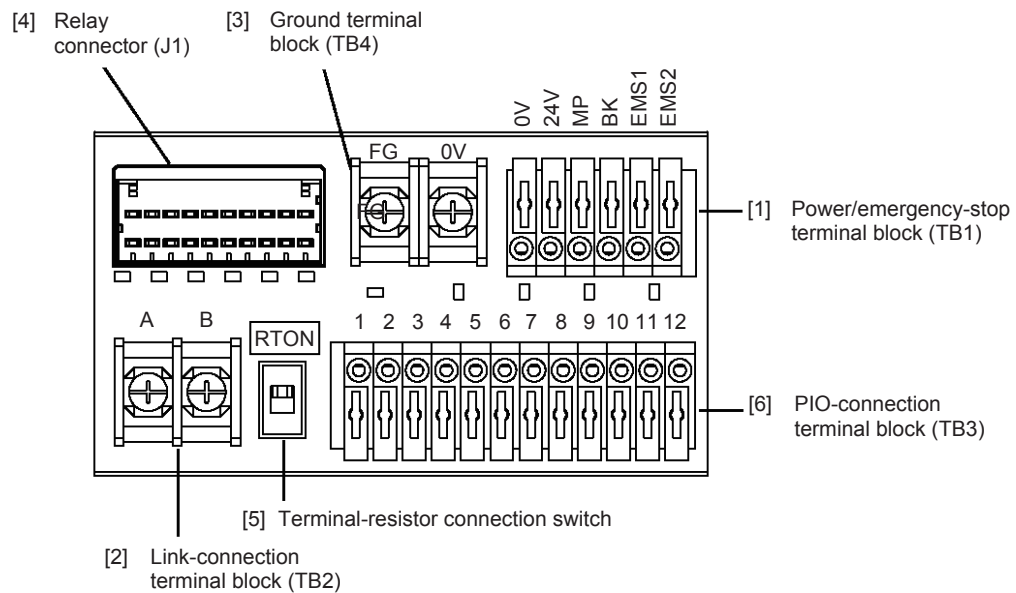

[1] Power/emergency-stop terminal block (TB1)

EMS1, EMS2	Provide a contact output for the emergency-stop switch on the teaching pendant (RCM-T/E). EMS1 and EMS2 are provided to comprise an interlock with a safety circuit provided by the user when a teaching pendant with emergency-stop switch is connected to the connector on the rear cover.
BK	Connection port for the brake release switch
MP	Motor power supply port
24V	Positive side of the 24-V control power supply
0V	Negative side of the 24-V control power supply

[2] Link-connection terminal block (TB2)

A connection port for linking a SIO converter, if used.

“A” on the left side connects to link-connection terminal block (A) on the SIO converter.

“B” on the right side connects to link-connection terminal block (B) on the SIO converter.

(Note) Be sure to use twisted pair wires for the above two lines (SGA/SGB).

[3] Frame-ground/ground terminal block (TB4)

- Frame-ground terminal (FG) . . . (1) A connection port for the extension cable’s shielded wire (ground).
(2) A connection port for the ground wire leading to the enclosure.
- Ground terminal (0 V) . . . Use this terminal as a relay port to connect a different power-supply line to the same grounding point.

[4] Relay connector (J1)

A connector port for the extension cable (CB-ERC-PWBIO-***-H6).

[5] Terminal-resistor connection switch

If a SIO converter is used and the link cable is long (10 m or more, as a guideline), a terminal resistor will be required to prevent signal reflection.

This unit can be used in the above application, because the TB2 terminal block has a built-in terminal resistor.

Setting the switch to the [RTON] side will connect the terminal resistor of approx. 120 Ω.

[6] PIO connection terminal block (TB3)
A PLC connection port. Detailed signal specifications are shown below.

[1] RCB-TU-PIO-A/B (When the control board is of the NPN specification)

TB3	PIO pattern			Remarks
	0 (8-point type)	1 (3-point type)	2, 3 (16-point type)	
1	Input common (In-COM) 24 [V] (Note 1)			LED 11 illuminates when 24 V is supplied.
2	Command position 1 (PC1)	Move to rear end (ST0)	Command position 1 (PC1)	LED1 illuminates when this signal turns ON.
3	Command position 2 (PC2)	Move to front end (ST1)	Command position 2 (PC2)	LED2 illuminates when this signal turns ON.
4	Command position 4 (PC4)	Move to intermediate point (ST2)	Command position 4 (PC4)	LED3 illuminates when this signal turns ON.
5	Home return (HOME)		Command position 8 (PC8)	LED4 illuminates when this signal turns ON.
6	Start (CSTR)		Start (CSTR)	LED5 illuminates when this signal turns ON.
7	*Pause (*STP)	*Pause (*STP)	*Pause (*STP)	LED6 illuminates when this signal turns ON.
8	Position complete (PEND)	Rear end (PE0)	Position complete (PEND)	LED7 illuminates when this signal turns ON.
9	Home-return completion (HEND)	Front end (PE1)	Home-return completion (HEND)	LED8 illuminates when this signal turns ON.
10	Zone output (ZONE)	Intermediate point (PE2)	Zone output (ZONE)	LED9 illuminates when this signal turns ON.
11	*Alarm (*ALM)	*Alarm (*ALM)	*Alarm (*ALM)	LED10 illuminates when this signal turns ON.
12	Output common (Out-COM) 0 [V] (Note 1)			

(Note 1) The input common and output common become 0 [V] and 24 [V], respectively, in the PNP specification.

[2] RCB-TU-PIO-AP/BP (When the control board is of the PNP specification)

TB3	PIO pattern			Remarks
	0 (8-point type)	1 (3-point type)	2, 3 (16-point type)	
1	Input common (In-COM) 0 [V] (Note 2)			LED 11 illuminates when 24 V is supplied.
2	Command position 1 (PC1)	Move to rear end (ST0)	Command position 1 (PC1)	LED1 illuminates when this signal turns ON.
3	Command position 2 (PC2)	Move to front end (ST1)	Command position 2 (PC2)	LED2 illuminates when this signal turns ON.
4	Command position 4 (PC4)	Move to intermediate point (ST2)	Command position 4 (PC4)	LED3 illuminates when this signal turns ON.
5	Home return (HOME)		Command position 8 (PC8)	LED4 illuminates when this signal turns ON.
6	Start (CSTR)		Start (CSTR)	LED5 illuminates when this signal turns ON.
7	*Pause (*STP)	*Pause (*STP)	*Pause (*STP)	LED6 illuminates when this signal turns ON.
8	Position complete (PEND)	Rear end (PE0)	Position complete (PEND)	LED7 illuminates when this signal turns ON.
9	Home-return completion (HEND)	Front end (PE1)	Home-return completion (HEND)	LED8 illuminates when this signal turns ON.
10	Zone output (ZONE)	Intermediate point (PE2)	Zone output (ZONE)	LED9 illuminates when this signal turns ON.
11	*Alarm (*ALM)	*Alarm (*ALM)	*Alarm (*ALM)	LED10 illuminates when this signal turns ON.
12	Output common (Out-COM) 24 [V] (Note 2)			

(Note 2) The input common and output common become 24 [V] and 0 [V], respectively, in the NPN specification.

- Internal connection diagram
- [1] RCB-TU-PIO-A/B

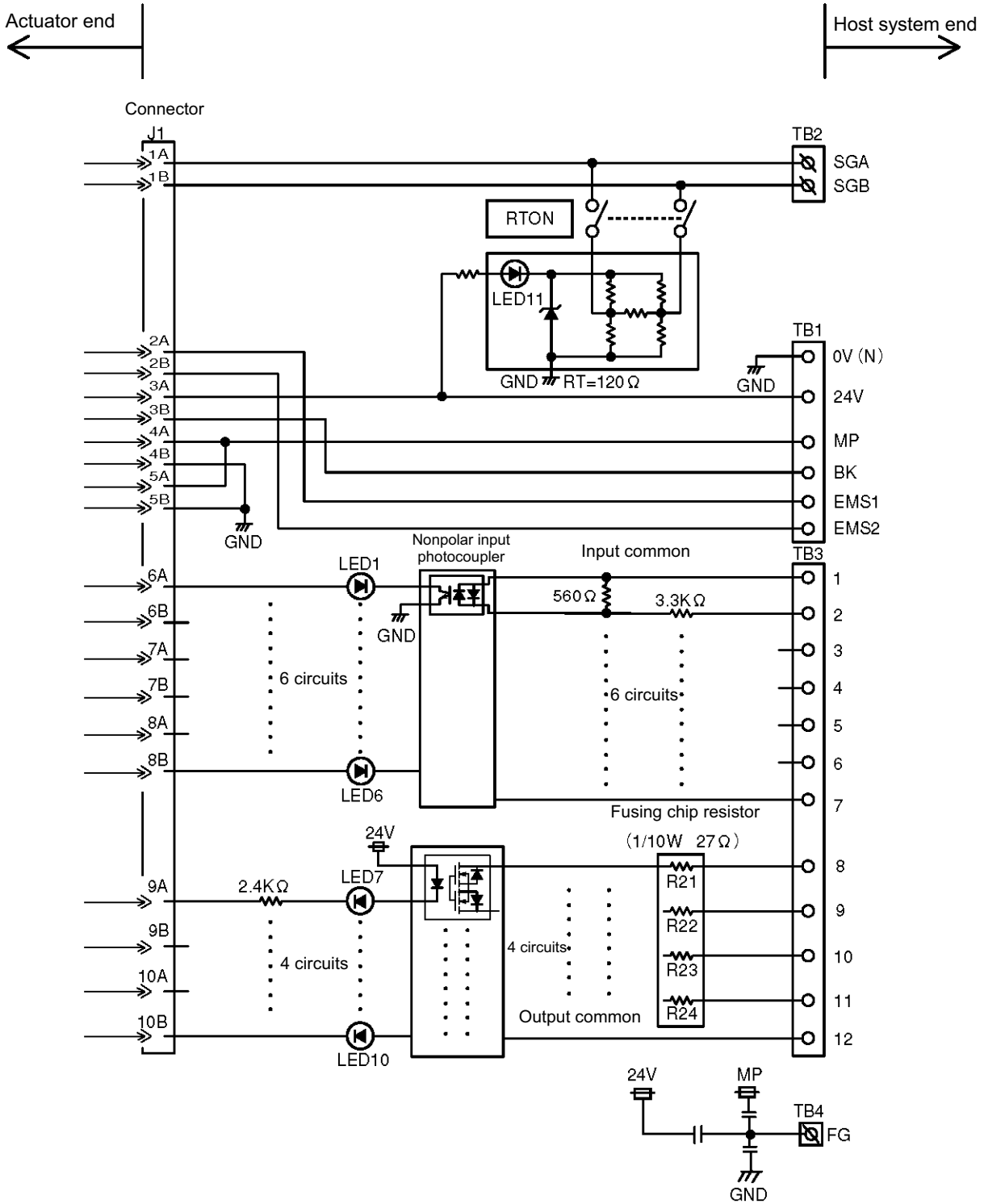

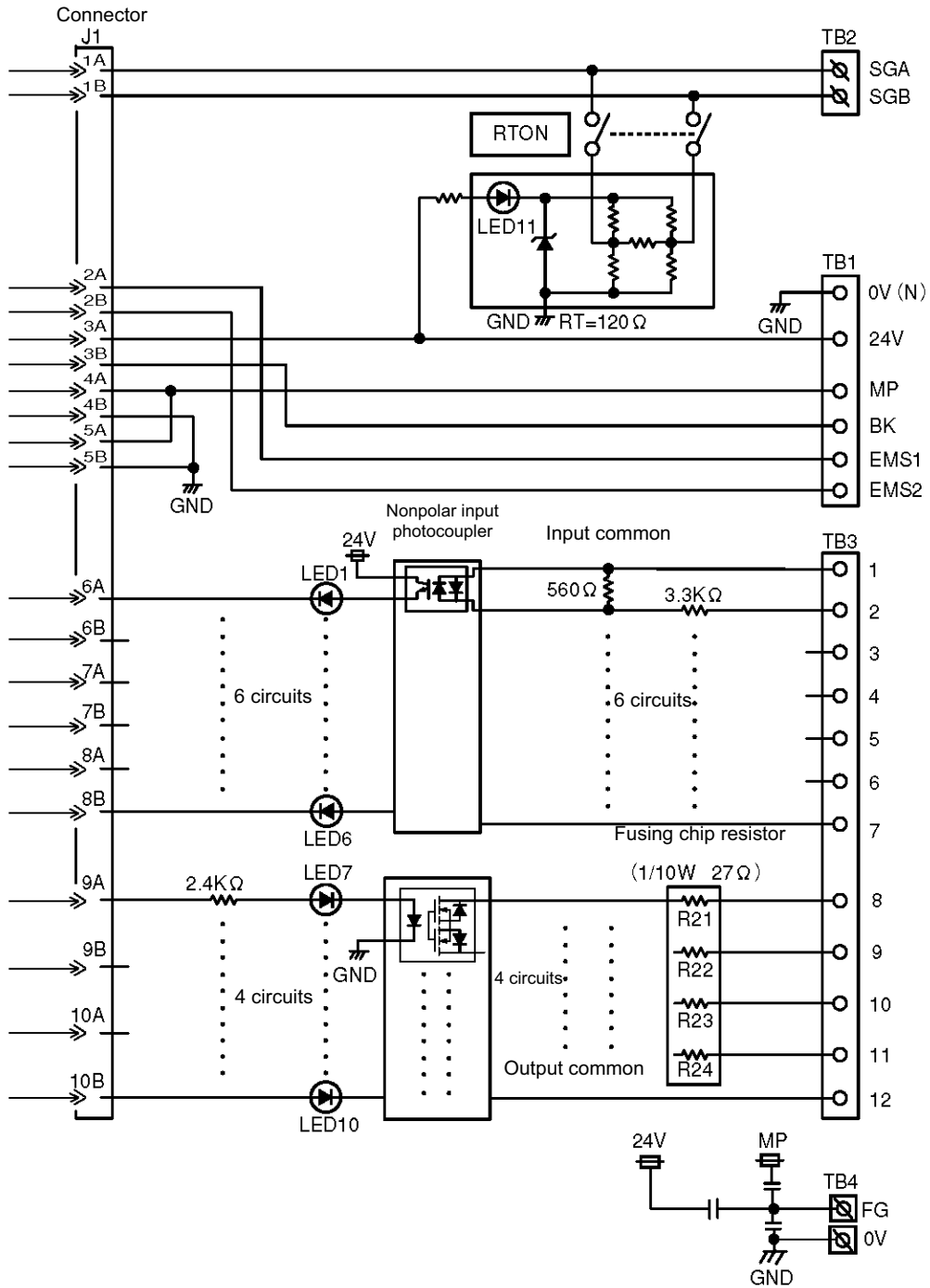

- I/O interface specifications

Input Specifications

Specification item	Description
Number of input points	6 points
Input voltage	$\pm 24 \text{ VDC} \pm 10\%$
Input current	7 mA/circuit (bipolar)
Allowable leak current	1 mA/point (approx. 2 mA at normal temperature)
Operating voltage	ON voltage: 16 V min. (4.5 mA) OFF voltage: 5 V max. (1.3 mA)

Output Specifications

Specification item	Description
Number of output points	4 points
Rated load voltage	24 VDC
Maximum current	60 mA/point
Residual voltage	2 V or less/60 mA
Shorting/overcurrent protection	Fusing resistor (27 Ω , 0.1 W)

5. Data Entry <Basic>

To move the actuator to a specified position, you must enter the target position in the “Position” field of the position table.

The target position can be specified in two different modes: by absolute coordinate specification (absolute mode) in which the distance from the home is entered, or by relative coordinate specification (incremental mode) in which the incremental travel from the current position is entered.

Once the target position is entered, other fields will be automatically populated by the default values set by the parameters.

The default values vary in accordance with the characteristics of the actuator.

5.1 Description of Position Table

The position table is explained by using the screen on the PC software as an example. (The displayed items vary on the teaching pendant screen.)

No	Position [mm]	Speed [mm/s]	Acceleration [G]	Deceleration [G]	Push [%]	Threshold [%]	Positioning band [mm]
0	5.00	300.00	0.30	0.30	0	0	0.10
1	380.00	300.00	0.30	0.10	0	0	0.10
2	200.00	300.00	0.30	0.10	0	0	0.10

Zone+ [mm]	Zone- [mm]	Acceleration/ deceleration mode	Incremental	Command mode	Standstill mode	Comment
100.00	0.00	0	0	0	4	Standby position
400.00	300.00	0	0	0	0	
250.00	150.00	0	0	0	0	

- (1) No.
 - Indicate the position data number. A position is defined as explained below.
- (2) Position
 - Enter the target position to move the actuator to, in [mm].
 - Absolute mode: Enter the distance to the target actuator position from the actuator's home.
 - Incremental mode: Enter the distance to the target actuator position from the current position by assuming a movement by constant pitch feed.

No	Position [mm]
0	30.00
1	\pm 10.00
2	\pm -10.00

Absolute mode The target is 30 mm from the home.
 Incremental mode +10 mm from the current position.
 Incremental mode -10 mm from the current position.

* On the teaching pendant screen, this sign indicates that the position is specified in the incremental mode.

- (3) Speed
 - Enter the speed at which the actuator will be moved, in [mm/sec]. The default value varies depending on the actuator type.

- (4) Acceleration/Deceleration
- Enter the acceleration/deceleration at which the actuator will be moved, in [G]. Basically, you should set values within the rated range specified in the catalog. The input range is greater than the rated range in the catalog, in order to accommodate situations where you want to "shorten the tact time when the transferring mass is much smaller than the rated loading capacity." If the load vibrates during acceleration/deceleration and causes problem, decrease the set values.

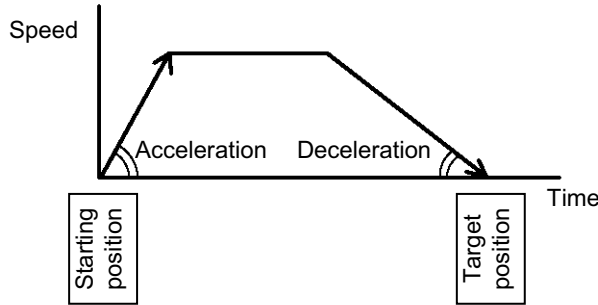

Increasing the set value makes acceleration/deceleration quicker, while decreasing the set value makes acceleration/deceleration more gradual.

⚠ Caution: When setting the speed and acceleration/deceleration, refer to 1.3, "Specifications" and enter appropriate values that will prevent the actuator from receiving excessive impact or vibration, by considering the installation conditions and shape of the load. Increasing the speed and acceleration/deceleration changes the transferring mass significantly, and the actuator characteristics also vary from one model to another. Therefore, consult IAI's Sales Engineering Section for the maximum limits that can be entered in your specific application.

- (5) Push
- Select "positioning operation" or "push & hold operation." The factory setting is "0."
0: Normal positioning operation
Other than 0: Push & hold operation (The set value defines the current-limiting value.)
- (6) Threshold
- This field is not used for this controller. The factory setting is "0."
- (7) Positioning band
- The meaning of the positioning band varies between "positioning operation" and "push & hold operation."

"Positioning operation"

The set value defines the distance before the target position at which the position complete signal will turn ON. Increasing the positioning band quickens the start of the next operation in the sequence, meaning that the tact time can be reduced. Set an appropriate value based on the overall balance of your system.

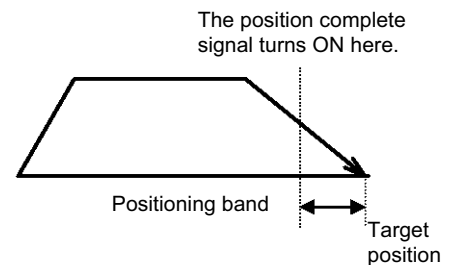

“Push & hold operation”

The set value defines the maximum distance the actuator will push the work part in the push & hold mode upon reaching the target position. Consider the mechanical variations of the work part and set an appropriate positioning band so that positioning will not complete before the actuator contacts the work part.

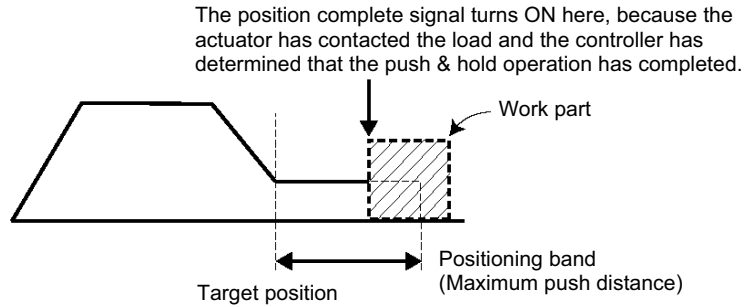

(8) Zone+/-

- These settings define the zone in which the zone output signal will turn ON when PIO pattern 3 is selected. For added flexibility, different values can be set for each target position.

[Setting example]

No	Position [mm]	Zone+ [mm]	Zone- [mm]
0	5.00	100.00	0.00
1	380.00	400.00	300.00
2	200.00	250.00	150.00

Movement command to position No. 0

Zone output signal

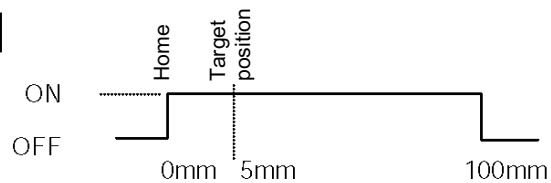

Movement command to position No. 1

Zone output signal

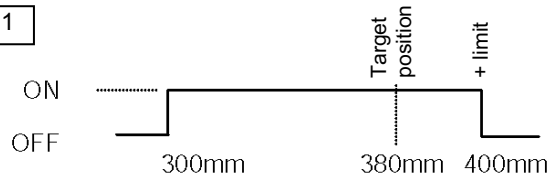

Movement command to position No. 2

Zone output signal

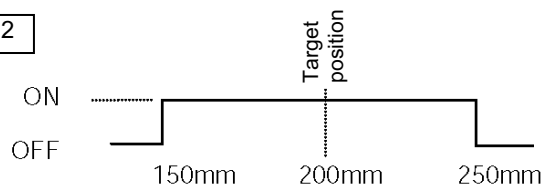

- (9) Acceleration/deceleration mode
 - This field is not used for this controller. The factory setting is "0."
- (10) Incremental
 - This setting defines whether to use the absolute mode or incremental mode. The factory setting is "0."
 - 0: Absolute mode
 - 1: Incremental mode
- (11) Command mode
 - This field is not used for this controller. The factory setting is "0."
- (12) Standstill mode
 - This setting defines the power-saving mode to be applied when the actuator is standing by after completing the positioning to the target position set in the "Position" field for the applicable position number.
 - 0: All power-saving modes are disabled. * The factory setting is "0: [Disable]."
 - 1: Automatic servo-off mode. The delay time is defined by parameter No. 36.
 - 2: Automatic servo-off mode. The delay time is defined by parameter No. 37.
 - 3: Automatic servo-off mode. The delay time is defined by parameter No. 38.
 - 4: Full servo control mode

Full servo control mode

The pulse motor is servo-controlled to reduce the holding current. Although the exact degree of current reduction varies depending on the actuator model, load condition, etc., the holding current decreases to approx. one-half to one-fourth. Since the servo remains on, no position deviation occurs. The actual holding current can be checked in the current monitor screen of the PC software.

Automatic servo-off mode

After positioning is completed, the servo will turn off upon elapse of a specified time. (Since no holding current flows, the power consumption decreases.) When the PLC issues the next movement command, the servo will turn on and the actuator will start moving.

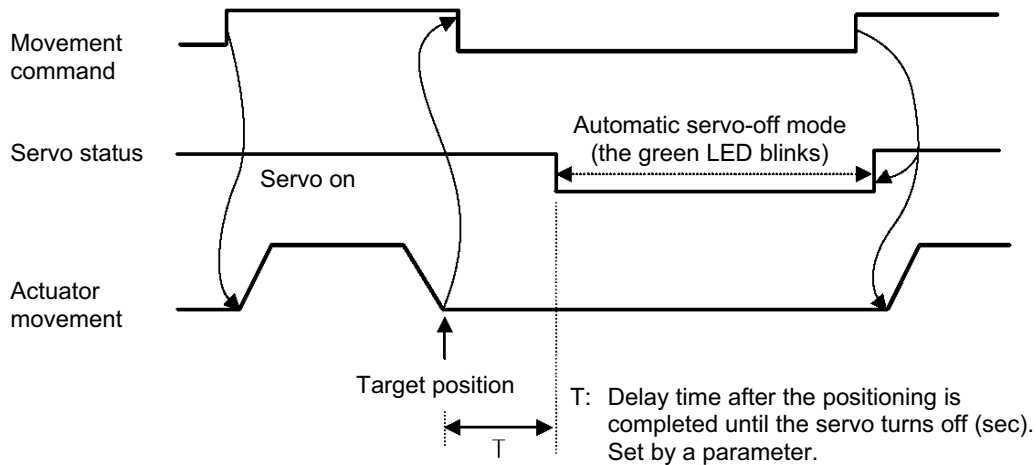

5.1.1 Relationship of Push Force at Standstill and Current-Limiting Value

When performing operation in the push & hold mode, enter the current-limiting value (%) in the push column of the position-data table.

Determine the current-limiting value (%) from the push force to be applied to the work part at standstill.

The graphs below illustrate the relationship of push force at standstill and current-limiting value for each actuator type:

- Slider type

(1) SA6C type

(2) SA7C type

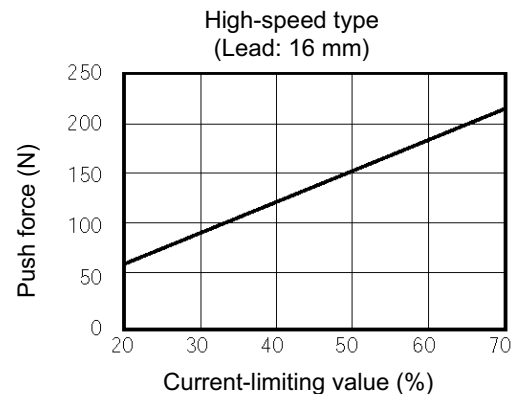
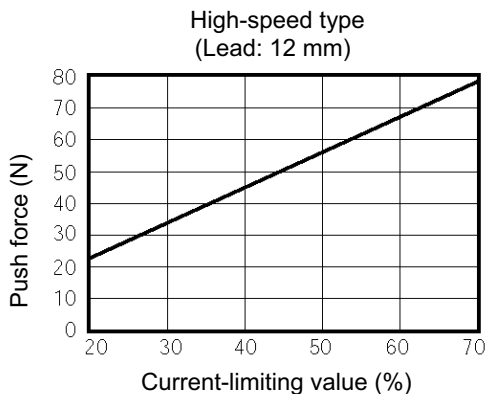
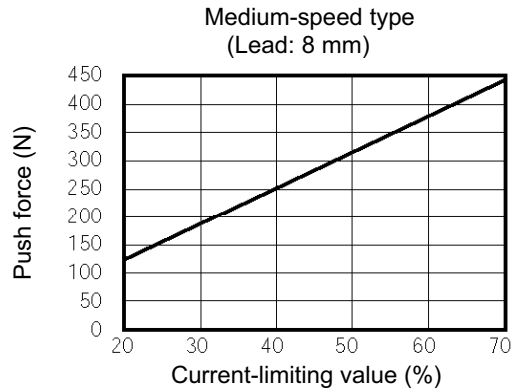
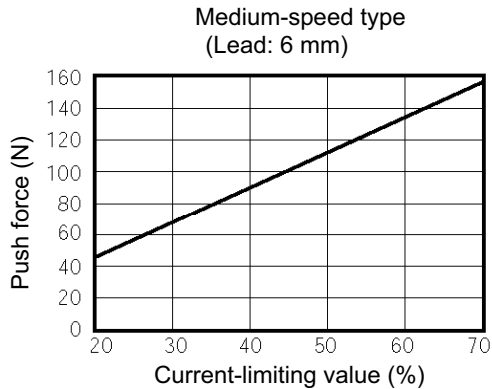
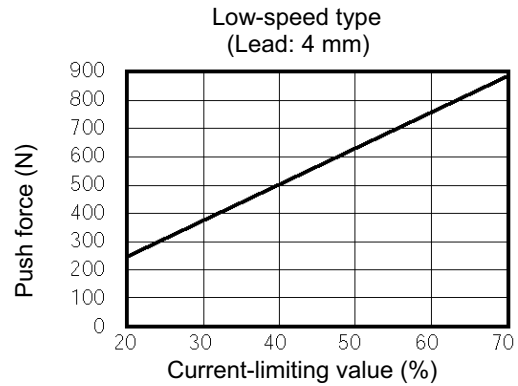
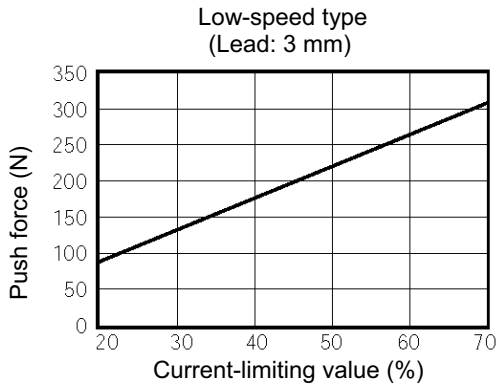

Caution: The accuracy of push force at standstill is not guaranteed. The above graphs are provided for reference purposes only. If the push force is too small, malfunction may occur during push & hold operation due to slide resistance, etc., so exercise caution. The maximum current-limiting value is shown in the above graphs. The minimum value is 20%.

● Rod type

(1) RA6C type

Low-speed type
(Lead: 3 mm)

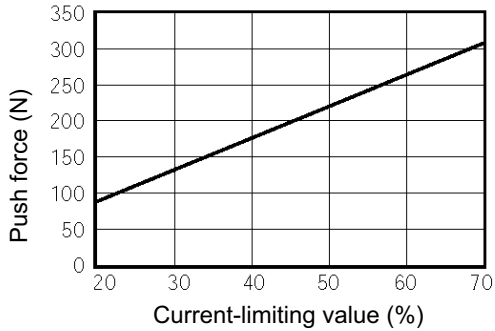

Medium-speed type
(Lead: 6 mm)

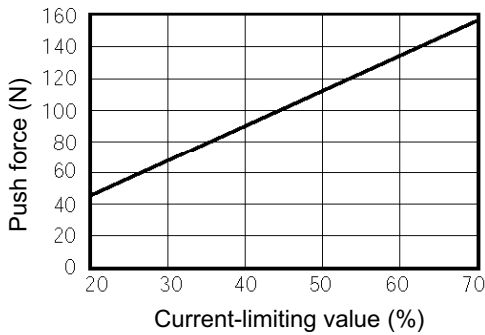

High-speed type
(Lead: 12 mm)

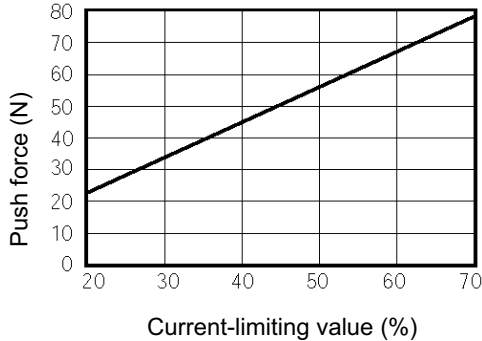

(2) RA7C type

Low-speed type
(Lead: 4 mm)

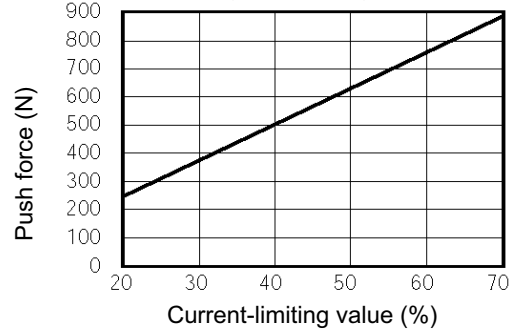

Medium-speed type
(Lead: 8 mm)

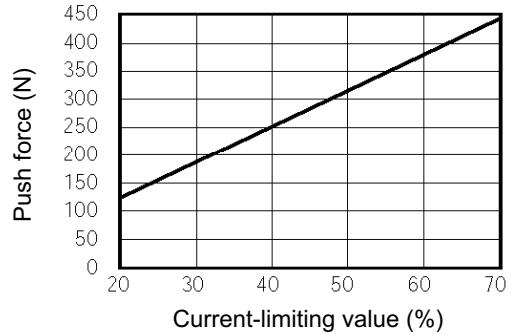

High-speed type
(Lead: 16 mm)

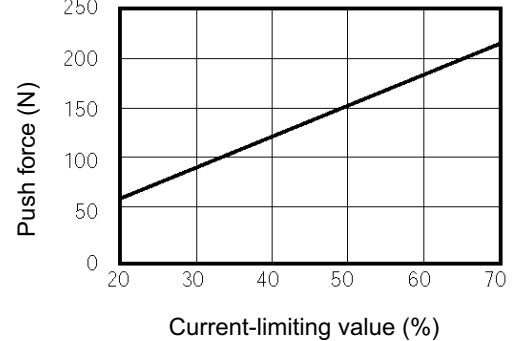

Caution: The accuracy of push force at standstill is not guaranteed. The above graphs are provided for reference purposes only. If the push force is too small, malfunction may occur during push & hold operation due to slide resistance, etc., so exercise caution. The maximum current-limiting value is shown in the above graphs. The minimum value is 20%.

5.2 Explanation of Functions

5.2.1 Positioning Mode Push = 0

The actuator moves to the target position set in the "Position" field of the position table.

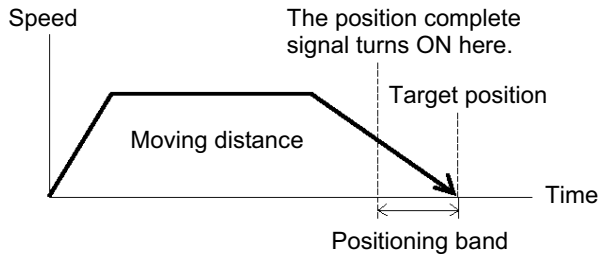

5.2.2 Push & Hold Mode Push = Other than 0

(1) Work part was contacted successfully

After reaching the target position set in the "Position" field of the position table, the actuator moves at the push speed for the distance set in the "Positioning band" field.

If the actuator contacts the work part before reaching the end of the specified distance, the controller will determine that the "push & hold operation has completed" and turn ON the position complete signal.

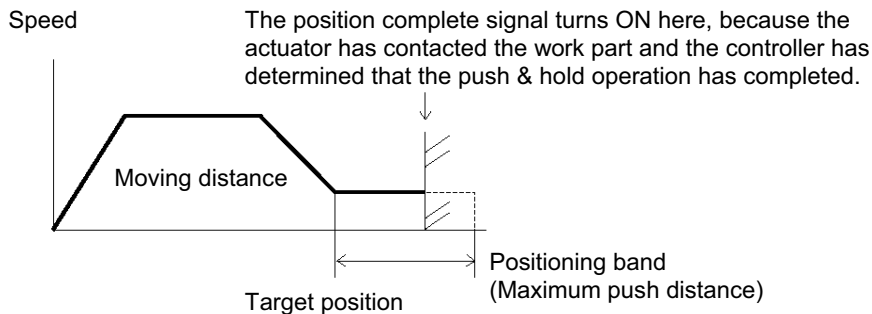

- The push speed is set by parameter No. 34. The factory setting is different for each actuator in accordance with the actuator's characteristics. Set an appropriate speed by considering the material and shape of the work part, and so on. Take note that the maximum speed is "20 [mm/s]" and that you should set a speed not exceeding this value.
- When setting a positioning band, consider the mechanical variations of the work part and set a distance slightly longer than the last position.
- "Completion of push & hold operation" is determined by the combination of the current-limiting value set in the "Push" field of the position table and the push completion judgment time set in parameter No. 6. Set an appropriate condition by considering the material and shape of the work part, and so on. For details, refer to 8, "Parameter Settings."

Warning

- If the actuator contacts the work part before reaching the target position, a servo alarm will occur. Pay due attention to the relationship between the target position and the position of the work part.
- The actuator continues to push the work part at the push force at standstill determined by the current-limiting value. Since the actuator is not inactive, exercise due caution when handling the machine in this condition.

(2) Work part was not contacted (missed)

The position complete signal will not turn ON if the actuator does not yet contact the work part after moving the distance set in the "Positioning band" field.

Therefore, include a timeout check process in the sequence circuit on the PLC side.

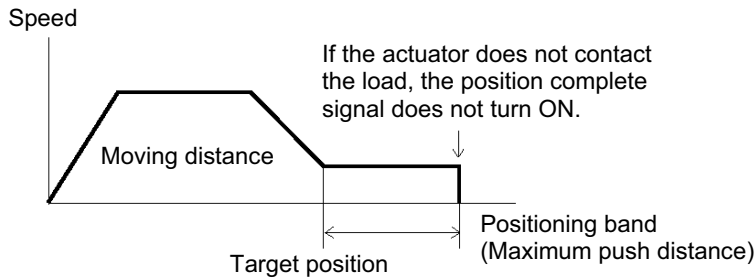

(3) Work part moves during push & hold operation

[1] The work part moves in the pushed direction

If the work part moves in the pushed direction after the push & hold operation has completed, the actuator will chase the work part within the positioning band.

If the current drops below the current-limiting value set in the "Push" field of the position table, the position complete signal will turn OFF. The signal will turn ON when the current rises to or above the current-limiting value again.

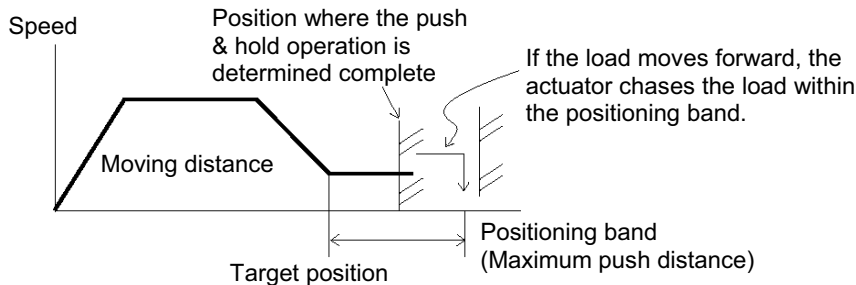

[2] The work part moves in the opposite direction

(The actuator is pushed back by a strong reactive force of the work part.)

If the actuator is pushed back after the push & hold operation has completed because the actuator thrust is smaller than the reactive force of the work part, the actuator will be pushed back all the way until its thrust balances out with the reactive force of the work part.

The position complete signal remains ON.

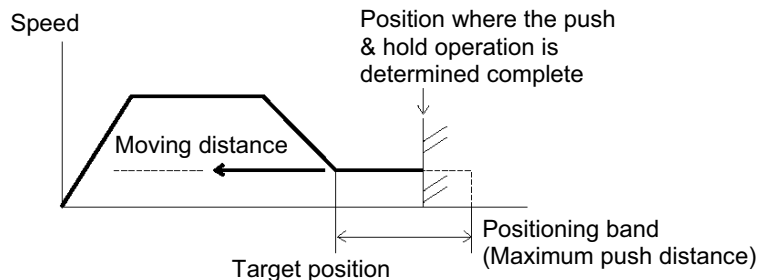

(Note) If the actuator is pushed back to the target position, an alarm will occur.

(4) Positioning band was entered with a wrong sign

If the value in the "Positioning band" field of the position table is entered with a wrong sign, the position will deviate by twice the positioning band, as shown below. Accordingly, pay due caution to the entry in this field.

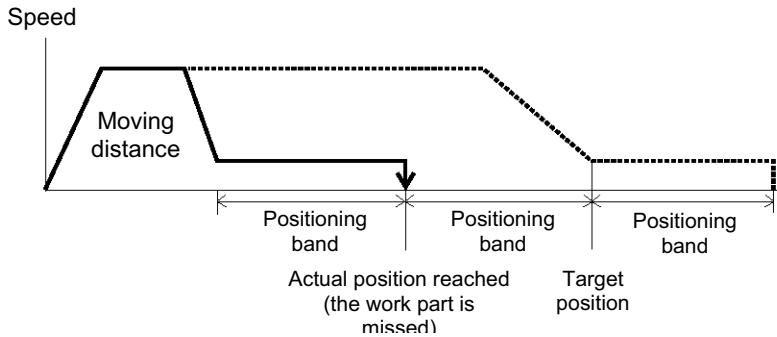

5.2.3 Speed Change during Movement

Speed control involving multiple speed levels is possible in a single operation. The actuator speed can be decreased or increased at a certain point during movement.

However, the position at which to implement each speed change must be set.

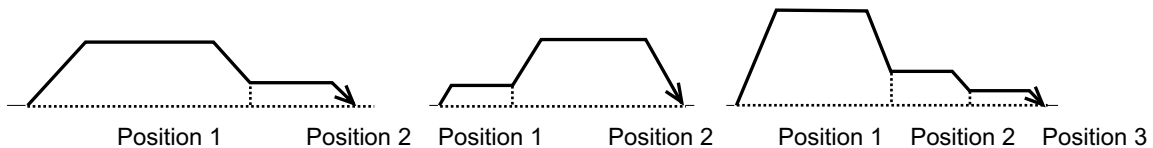

5.2.4 Operation at Different Acceleration and Deceleration Settings

If the work part is a CCD camera or other precision instrument, a more gradual deceleration curve is needed when the actuator stops.

To support these applications, the position table has separate fields for "Acceleration" and "Deceleration."

You can set the acceleration and deceleration differently, such as setting 0.3 G (rated value) in "Acceleration" and 0.1 G in "Deceleration."

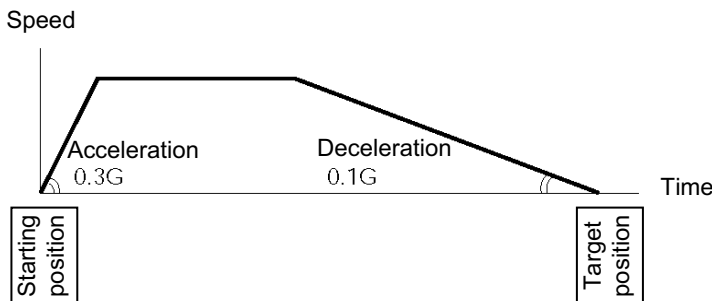

Caution: Basically, you should set the acceleration/deceleration within the rated range specified in the catalog. The input range is greater than the rated range in the catalog, in order to accommodate situations where you want to "shorten the tact time when the transferring mass is much smaller than the rated loading capacity." If the actuator is to be operated in this condition, however, its service life may be affected. Contact IAI beforehand for consultation.

5.2.5 Pause

The actuator can be paused during movement using an external input signal (*pause). The pause signal uses the contact B logic (always ON) to ensure safety. Turning OFF the *pause input will cause the actuator to decelerate to a stop, while turning it ON will allow the actuator to complete the remaining operation.

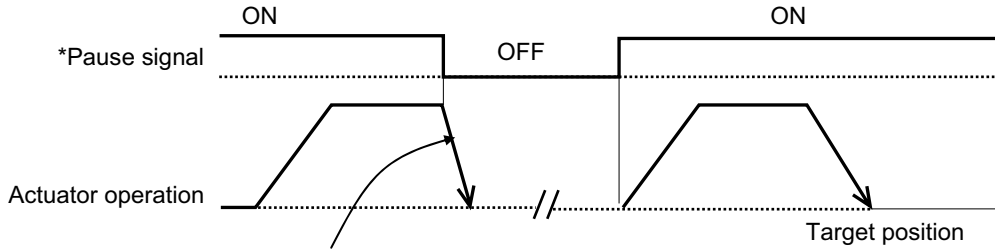

(Note) The deceleration becomes the value set in the “Deceleration” field of the position table for the position number corresponding to the current positioning operation.

5.2.6 Zone Signal Output

The zone signal is output when the actuator enters the specified zone during movement. Accordingly, this signal can be used for the following purposes:

- [1] As a trigger signal for peripheral equipment to reduce the tact time
- [2] To prevent contact with peripheral equipment
- [3] As a “simple ruler” in push & hold operation

The zone in which the signal turns ON varies depending on the PIO pattern

- PIO pattern = 0 (8 points) or 2 (16 points: setting by zone boundary parameters)
The zone in which the zone signal turns ON is set by parameters.
Parameter No. 1 = Zone boundary+, parameter No. 2 = Zone boundary–

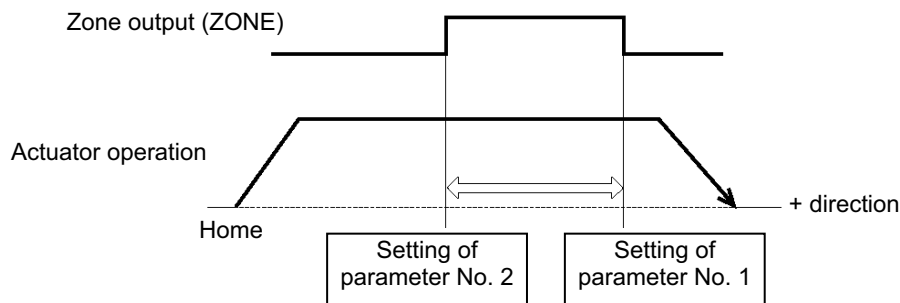

- PIO pattern = 3 (16 points: setting in zone fields in the position table)
The zone in which the zone signal turns ON is set by the “Zone–” and “Zone+” fields of the position table.

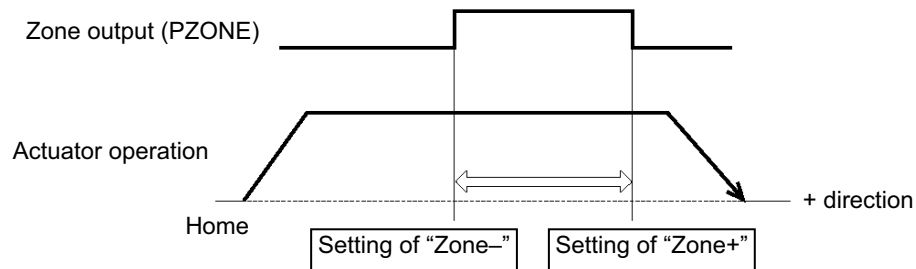

5.2.7 Home Return

After the power is turned on, home return must be executed to establish the home.

Upon occurrence of a cold-start level error, the power must be reconnected to restore the system. In this case, home return is also required after the reconnection of power.

Which home return method is used will vary depending on the PIO pattern selected.

- Home return using a dedicated input [PIO pattern = 0 (8 points)]
Home return can be executed using the home return (HOME) input.
Turning ON this input will execute home return regardless of whether or not it has already been executed once.
When the home return is complete, the home return completion (HEND) output will turn ON.
- Home return not using a dedicated input [PIO pattern = Other than 0]
Even if home return has not been executed yet, issuing a start command by specifying a position will cause the actuator to return to the home before moving to the specified position.
★ For details, refer to 7.3, "How to Execute Home Return."

5.3 Power-saving Modes at Standby Positions

One general feature of pulse motors is that their holding current in standstill state is greater than AC servo motors. Therefore, we provide energy-saving modes to reduce power consumption in situations where the actuator remains standstill for a long period at a standby position.

Use these modes after confirming that they will not present problems to any part of your system.

Each mode produces a different level of power-saving effect. Follow the instructions provided below and select an optimal mode appropriate for the specific standstill condition of your actuator.

- PIO pattern = Other than 0 [8 points]

The actuator stands by with the servo on after the power has been turned on

In this condition, you can select full servo control using parameter No. 53 (Default standstill mode). Automatic servo-off control cannot be selected. If you have set 1, 2 or 3 by mistake, the setting will be ignored. (This setting is not affected by the value in the "Standstill mode" field of the position table.)

The actuator stands by after completing the positioning to the target position set in the "Position" field for the applicable position number

In this condition, you can select one of two modes based on the value in the "Standstill mode" field of the position table.

(This setting is not affected by the value of parameter No. 53.)

- [1] Full servo control
- [2] Automatic servo-off control

- PIO pattern = 0 [8 points]

The actuator stands by after completing the home return effected by the HOME input signal

In this condition, you can select one of two modes based on the value in parameter No. 53 (Default standstill mode). (This setting is not affected by the value in the "Standstill mode" field of the position table.)

- [1] Full servo control
- [2] Automatic servo-off control

The actuator stands by after completing the positioning to the target position set in the "Position" field for the applicable position number

In this condition, you can select one of two modes based on the value in the "Standstill mode" field of the position table.

(This setting is not affected by the value of parameter No. 53.)

- [1] Full servo control
- [2] Automatic servo-off control

Meanings of values set in the "Standstill mode" field of the position table and in parameter No. 53

	Setting
All power-saving modes are disabled. (The actuator is completely stopped.)	0
Automatic servo-off mode. The delay time is defined by parameter No. 36.	1
Automatic servo-off mode. The delay time is defined by parameter No. 37.	2
Automatic servo-off mode. The delay time is defined by parameter No. 38.	3
Full servo control mode	4

■ Full servo control mode

The pulse motor is servo-controlled to reduce the holding current.

Although the exact degree of current reduction varies depending on the actuator model, load condition, etc., the holding current decreases to approx. one-half to one-fourth.

Since the servo remains on, no position deviation occurs.

The actual holding current can be checked in the current monitor screen of the PC software.

Take note that micro-vibration or noise may occur in certain conditions where external force is applied, or depending on the position where the actuator has stopped.

If micro-vibration or noise presents problem, do not use this mode.

■ Automatic servo-off mode

After positioning is completed, the servo will turn off upon elapse of a specified time.

(Since no holding current flows, the power consumption decreases.)

When the PLC issues the next movement command, the servo will turn on and the actuator will start moving.

* Since the servo turns off once, some position deviation may occur.

Do not use this function at standby positions where position deviation will cause problem.

You should also note that all position complete signals (PEND, PE0, PE1, PE2) will turn OFF because the servo turns off.

However, you can keep the signals ON via a parameter in situations where the PLC sequence circuit is designed in such a way that problems will occur if position complete signals turn OFF.

Setting of parameter No. 39 (Output mode of position complete signal)	[1] PIO pattern = 1 (3 points) Rear end complete (PE0), front end complete (PE1), or intermediate point complete (PE2) [2] PIO pattern = 0, 2, 3 (8 points/16 points) Position complete (PEND)
0 [PEND]	The position complete signal is OFF unconditionally when the servo is off. Even when the next movement command is issued and the servo turns on again, the actuator has already started moving to the next target position, so the position complete signal still remains OFF.
1 [INP]	Even when the servo is off, the position complete signal turns ON if the current position is within the range set by the "Positioning band" field of the position table, with respect to the target position, and turns OFF if the current position is outside this range.

(Note) The factory setting is "0."

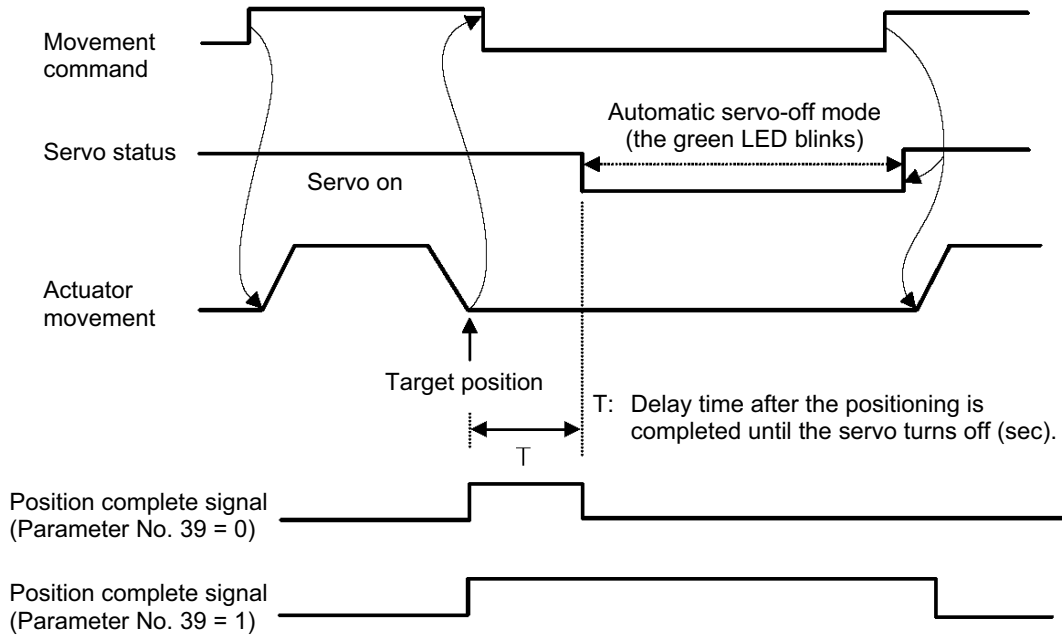

Setting method: Set one of the following values in the "Standstill mode" field of the position table:

- Set "1": T becomes the value of parameter No. 36.
- Set "2": T becomes the value of parameter No. 37.
- Set "3": T becomes the value of parameter No. 38.

Warning: If the next movement command is specified in the incremental mode (based on constant pitch feed), never use the automatic servo-off mode. The current position may deviate slightly as the servo turns off and then on again.

Caution: In push & hold operation, both the full servo control mode and automatic servo-off mode become ineffective once the operation has completed successfully. If the actuator has missed the work part, the specified mode becomes effective. Basically, you should not use either the full servo control mode or automatic servo-off mode in push & hold operation.

6. Operation in the “3 Points (Air Cylinder)” Mode <Practical Operation>

6.1 Overview of the “3 Points” Mode

This mode provides a control method adjusted to that of an air cylinder by assuming that the actuator is used as an air cylinder.

The key differences between the ERC2 and an air cylinder are summarized below. Perform proper control by referring to this table.

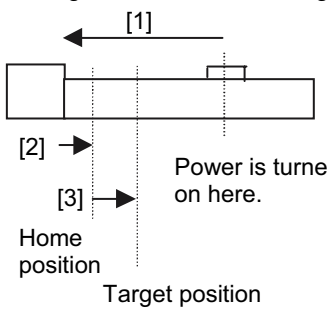
Item	Air cylinder	ERC2
Drive method	Air pressure supplied via electromagnetic valve control	Ball screw/timing belt driven by a motor
Target position setting	Mechanical stopper (including shock absorber)	Desired coordinates are entered in the [Target position] field of the position table. The coordinates can be typed in from the number keys on the PC keyboard or on the teaching pendant, or set directly by moving the actuator to the target position.
Target position detection	An external detection sensor, such as a reed switch, is installed.	Determined based on the internal coordinates provided by the position information from the position detector (encoder). Accordingly, external detection sensor is not required.
Speed setting	Adjusted by a speed controller.	A desired feed speed is entered in the [Speed] field of the position table (unit: mm/sec). Note that the rated speed is automatically set as the initial value.
Acceleration/deceleration setting	Determined in accordance with the load, supplied air volume, as well as the performance of the speed controller and electromagnetic valve.	A desired acceleration/deceleration is entered in the [Acceleration/deceleration] field of the position table (unit: 0.01 G). (Reference) 1 G = Gravitational acceleration Note that the rated acceleration/deceleration is automatically set as the initial value. Since the acceleration/deceleration can be set in fine steps, a gradual acceleration/deceleration curve can be programmed.
Position check upon power ON	Determined by an external detection sensor, such as a reed switch.	Immediately after the power is turned on, the controller cannot identify the current position because the mechanical coordinates have been lost. Therefore, when the first movement command is issued after the power has been input, the controller will automatically perform home return before moving the actuator to the target position.  [1] The actuator moves at the home return speed toward the mechanical end on the motor side. [2] The actuator hits the mechanical end and turns back, and then stops temporarily at the home position. [3] The actuator moves to the target position at the speed specified in the [Speed] field of the position table. (Note) Pay attention not to allow any obstacle in the travel path of the actuator during home return.

The relationships of movement command inputs/position complete outputs and corresponding position numbers are shown below.

For easier identification, each input/output signal has a name similar to the naming convention used with air cylinders. However, note that the target position is determined by the value set in the [Target position] field under each position number. Therefore, changing the magnitude correlation of the settings in Nos. 0 to 2 will change the meanings of the corresponding input/output signals.

Accordingly, the settings in the respective position numbers should match the semantic meanings of the corresponding signal names used in this operation manual, unless doing so will pose a problem.

Input signal	Output signal	Target position
Rear end move (ST0)	Rear end complete (PE0)	Setting in the [Target position] field under position No. 0 Example: 5 mm
Front end move (ST1)	Front end complete (PE1)	Setting in the [Target position] field under position No. 1 Example: 390 mm
Intermediate point move (ST2)	Intermediate point complete (PE2)	Setting in the [Target position] field under position No. 2 Example: 200 mm

- Positioning relationships on the Robo Cylinder
This example assumes the use of a slider type actuator with a 400 mm stroke.

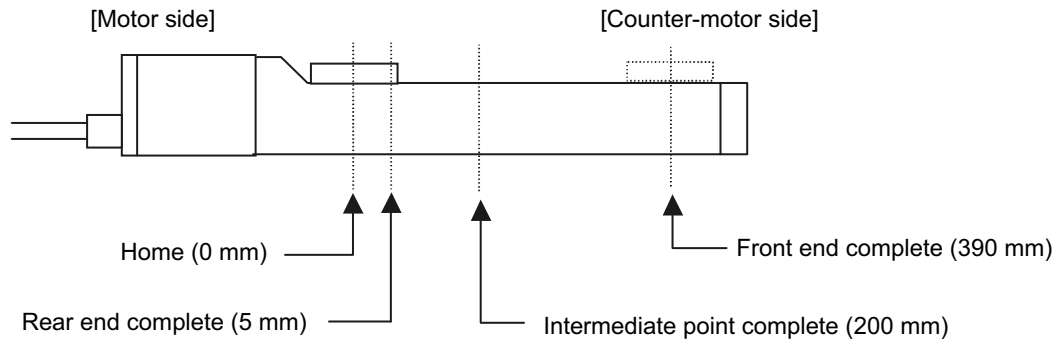

- Position table (Field(s) within thick line must be entered.)

No.	Position [mm]	Speed [mm/s]	Acceleration [G]	Deceleration [G]	Push [%]	Positioning band [mm]
0	5.00	500.00	0.30	0.30	0	0.10
1	390.00	500.00	0.30	0.30	0	0.10
2	200.00	500.00	0.30	0.30	0	0.10

6.2 How to Start

- (1) Confirm that the connector end (CN1) of the extension cable is firmly plugged into the connector on the actuator cable.
- (2) Connect the PLC and the parallel I/O.
- (3) If the actuator has brake, set the brake release switch to OFF.
- (4) Supply 24 VDC to the control power supply.
Cut off the motor-drive power supply (actuate an emergency stop) beforehand.
- (5) Confirm that the slider or rod is not contacting the mechanical end. If the slider or rod is contacting the mechanical end, or when the slider or rod is positioned between the mechanical end and home, move the slider/rod away from the home position toward the direction opposite to the mechanical end.
If the actuator is equipped with a brake, move the slider/rod after releasing the brake by turning on the brake release switch. At this time, pay attention to prevent the load from falling by its dead weight and protect your hand, robot, and the work part from injuries/damages.
If the screw lead is too short and the actuator cannot be moved by hand, change the setting of parameter No. 28, "Direction of excited-phase signal detection" to the direction opposite to the mechanical end.

 **Warning:** Turning on the servo while the slider or rod is still contacting the mechanical end may disable accurate detection of the excited phase, resulting in malfunction or excitation detection error.

- (6) Connect a PC or teaching pendant and set the minimum parameters required.
 - If the pause input is not used, set parameter No. 15 "Pause input disable selection" to "1."
 - Set parameter No. 25 "PIO pattern selection" to "1" (this setting is required).
 - If you want to use the movement command input based on the "edge mode," set parameter No. 27 to "1."For details, refer to 8, "Parameter Settings."
- (7) Cancel the emergency stop so that the motor drive power will be supplied.
 - ★ The controller servo will be turned on and a green LED lamp will illuminate on the motor cover.
- (8) If the pause signal (*STP) is enabled, turn the signal ON from the PLC.
 - ★ A red LED lamp indicates an alarm. Remove the cause of the alarm.
For details, refer to 9, "Troubleshooting."
- (9) Perform home return.
 - Overview of operation on the teaching pendant
 - On the RCM-T, select the Edit/Teach screen, bring the cursor to *Home in the sub-display area, and then press the ENTER key.
 - On the RCM-E, select the Teach/Play screen, scroll the pages until *Home Return is shown, and then press the ENTER key.
 - Overview of operation in the PC software
In the main window, select the applicable position data, and then click **Home**.

For details of each operation, refer to the operation manual for the applicable teaching pendant or PC software.

If the actuator does not perform home return, confirm that the *pause signal is ON, the motor-drive power supply is receiving power, and no error messages are displayed, among others.

- (10) Set the target position, speed, acceleration/deceleration, positioning band and other data in the position table. For details on how to set data in the position table, refer to the operation manual for the teaching pendant or PC software, whichever is applicable.
Now, you can operate the actuator automatically via control from the PLC.

Caution: Move the actuator to the target position after confirming that the *ALM output is ON and the motor drive power is supplied.

Timing chart at start

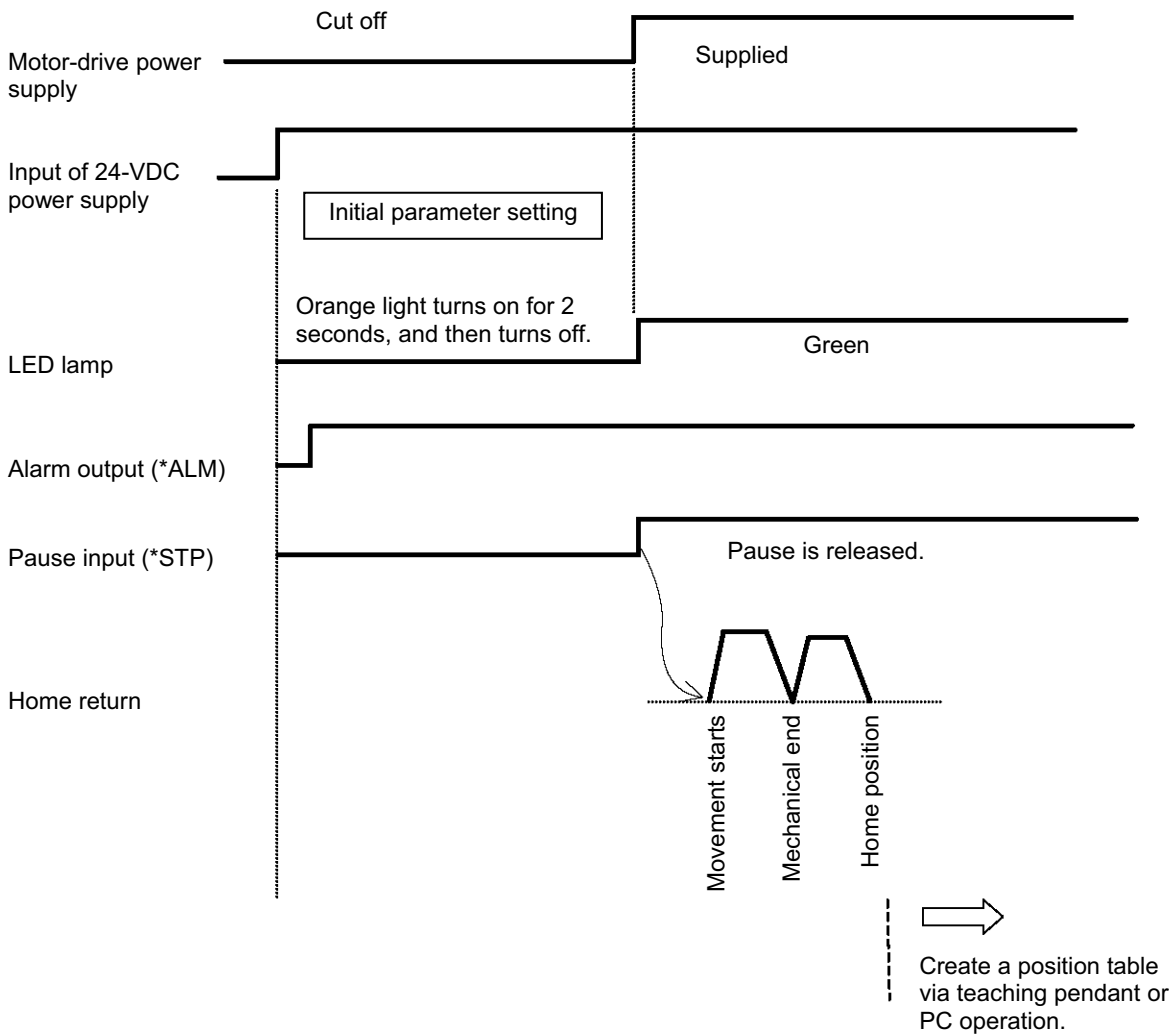

6.3 Position Table and Parameter Settings Required for Operation

6.3.1 Test Operation

Immediately after the system has been started, the moving speed can be reduced by the methods specified below to ensure safety of operators and prevent damage to jigs, etc.

Change the applicable parameters if necessary.

→ For details on the setting-change operations, refer to the operation manual for your PC software/teaching pendant.

Safety speed during manual feed

Parameter No. 35 defines the feed speed to be applied when the actuator is moved using a PC/teaching pendant.

The factory setting is "100 mm/s." Change this value if necessary.

Take note that the maximum speed is 250 mm/s.

Speed override for movement commands from the PLC

You can lower the feed speed to be applied when the actuator is moved by the movement commands to rear end/front end/intermediate point output from the PLC.

To lower the speed to below the level set in the "Speed" field of the position table, you can use parameter No. 46 to override the "Speed" field.

Actual moving speed = [Speed set in the position table] x [Value of parameter No. 46] ÷ 100

Example) Value in the "Speed" field of the position table 500 (mm/s)
 Value of parameter No. 46 20 (%)

Under the above settings, the actual moving speed becomes 100 mm/s.

The minimum setting unit is "1%," while the input range is "1 to 100 %." The factory setting is "100 %."

6.3.2 Full-scale Operation

We provide energy-saving modes to reduce power consumption in situations where the actuator remains standstill for a long period at a standby position.

You can also select the status of position complete signal to be applied if the servo turns off or “position deviation” occurs while the actuator is standing still after completing positioning.

Use these functions after confirming that they will not present problems to any part of your system.

Saving energy when the actuator stands by for a long time after the power has been turned on

In this condition, you can select full servo control using parameter No. 53 (Default standstill mode). (This setting is not affected by the value in the “Standstill mode” field of the position table.)

→ For details, refer to 5.3, “Power-saving Modes at Standby Positions” and 8.2.2, “Parameters Relating to the Actuator Operating Characteristics.”

Saving energy when the actuator stands by for a long time at the target position

In this condition, you can select one of two modes based on the value in the “Standstill mode” field of the position table. (This setting is not affected by the value of parameter No. 50.)

[1] Full servo control

[2] Automatic servo-off control

→ For details, refer to 5.3, “Power-saving Modes at Standby Positions” and 8.2.2, “Parameters Relating to the Actuator Operating Characteristics.”

Output mode of position complete signal

You can select the status of position complete signal to be applied if the servo turns off or “position deviation” occurs while the actuator is standing still after completing positioning.

This setting uses parameter No. 39. Consider the characteristics of the control you need and select an appropriate mode.

→ For details, refer to 8.2.3, “Parameters Relating to the External Interface.”

6.4 Moving Operation

First, make the controller ready to accept movement commands by referring to 6.2, "How to Start."

Example of use in operation) Turn on the power, and then cause the actuator to move back and forth between the rear end (5 mm) and front end (390 mm) via an intermediate point (200 mm).

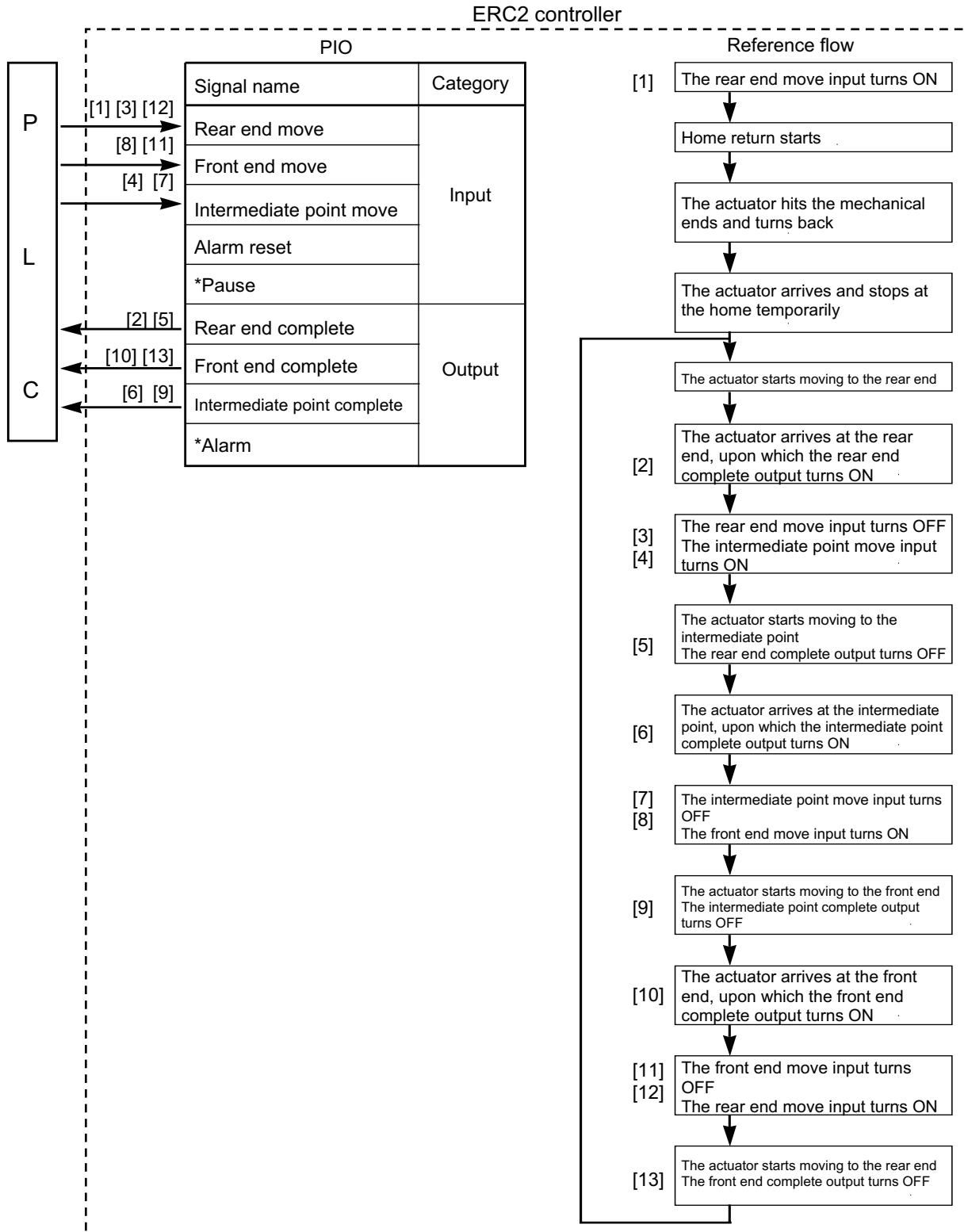

[Operation timings]

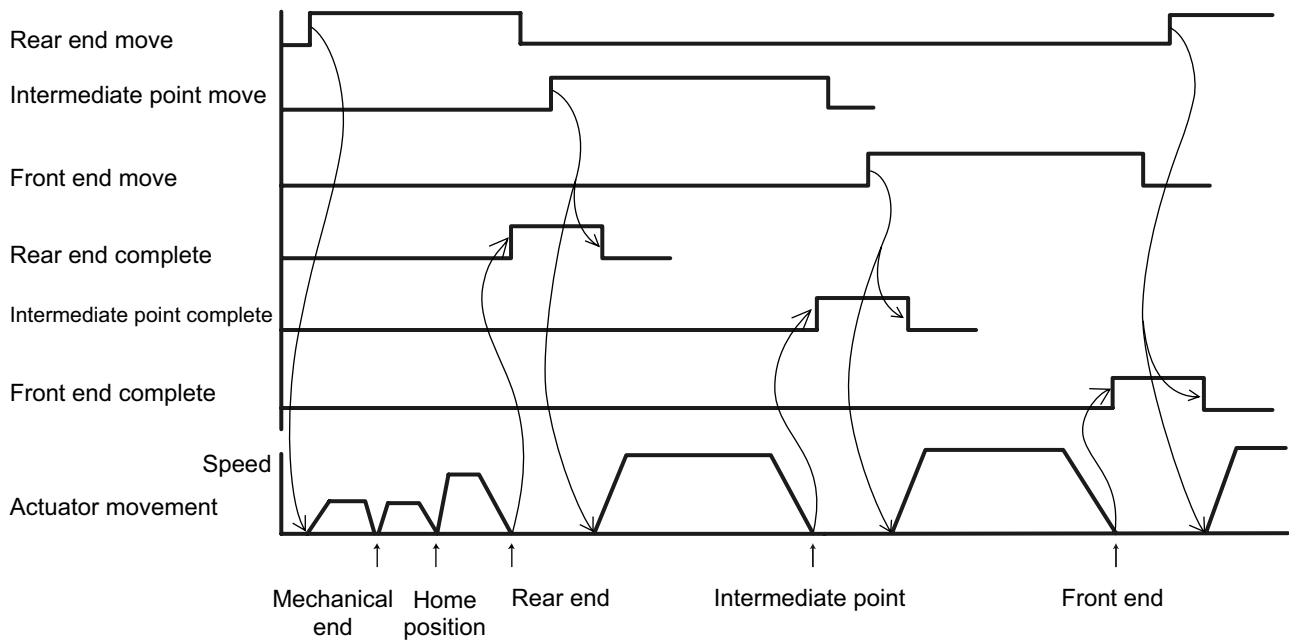

- ⚠ Caution:
- [1] Movement commands are executed based on the rise edge, so input each signal continuously for 6 msec or more. If two or more movement commands are input simultaneously, they will be executed according to the following priorities:
 - [2] Increasing the positioning band allows the position complete signal to turn ON more quickly, and consequently the next operation in the sequence starts early. This is an effective means for reducing the tact time, so set an optimal value based on the overall balance of your system.

- The movement command input operates in two modes.
You can select the operation condition of the movement command input (ST0 to ST2) in parameter No. 27.
The factory setting is "0: [Level mode]."

Description of the movement command input	Setting
Level mode: The actuator starts moving when the input signal turns ON. When the signal turns OFF during the movement, the actuator will decelerate to a stop and complete its operation.	0
Edge mode: The actuator starts moving when the rise edge of the input signal is detected. The actuator will not stop even when the signal turns OFF during the movement, until the target position is reached.	1

[Level mode]

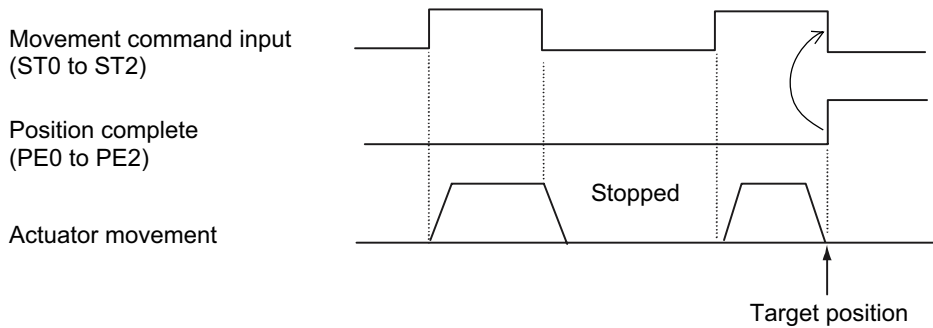

(Note) Turn OFF the movement command input after confirming that the target position has been reached.

[Edge mode]

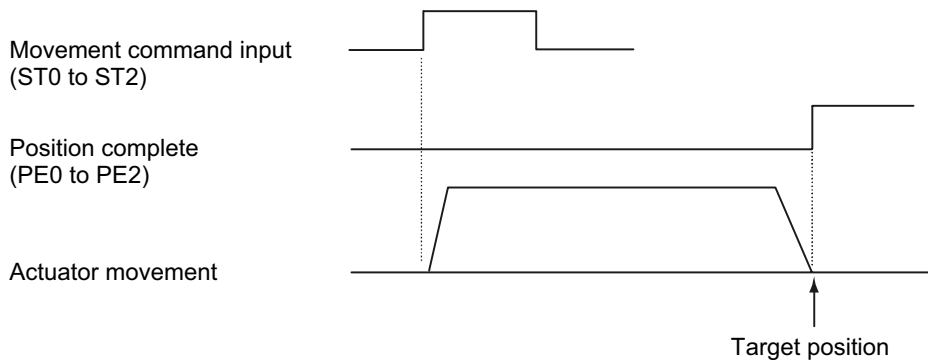

- Handling of the pause (*STP) signal
 This signal is a Contact B signal, meaning that it must remain ON while the actuator is moving.
 If the pause signal turns OFF while the actuator is moving, the actuator will decelerate to a stop.
 The actuator will start moving when the signal turns ON again.
 Use this signal as an interlock that actuates when an operator entry prohibition sensor or contact prevention sensor is activated.

If the pause signal is not to be used, set parameter No. 15 (Pause input disable selection) to "1," and the actuator will move even when this signal is OFF.

(Note) When the "edge mode" is selected as the movement command type, you may want to change the target position while the actuator is stopped with this signal turned OFF. In this case, input a movement command specifying the new target position, and then turn ON this signal.

- (Example) If the pause signal is turned OFF while the actuator is moving following the input of an intermediate point move command, the accelerator will decelerate to a stop.
- Turn OFF the intermediate point move signal, and then turn ON the front end move signal.
 - When the pause signal is turned ON again, the controller will recognize the front end as the new target position.

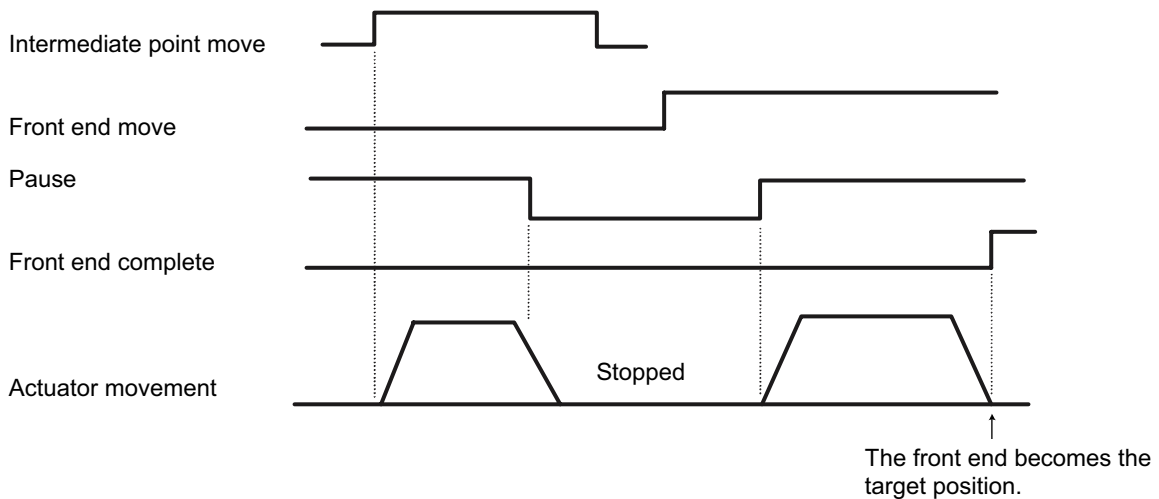

7. Operation in the “8 Points” and “16 Points” Modes <Practical Operation>

7.1 How to Start

- (1) Confirm that the connector end (CN1) of the extension cable is firmly plugged into the connector on the actuator cable.
- (2) Connect the PLC and the parallel I/O.
- (3) If the actuator has a brake, set the brake release switch to OFF.
- (4) Supply 24 VDC to the control power supply.
Cut off the motor-drive power supply (actuate an emergency stop) beforehand.
- (5) Confirm that the slider or rod is not contacting the mechanical end. If the slider or rod is contacting the mechanical end, or when the slider or rod is positioned between the mechanical end and home, move the slider/rod away from the home position toward the direction opposite to the mechanical end.
If the actuator is equipped with a brake, move the slider/rod after releasing the brake by turning on the brake release switch. At this time, pay attention to prevent the load from falling by its dead weight and protect your hand, robot, and the work part from injuries/damages.
If the screw lead is too short and the actuator cannot be moved by hand, change the setting of parameter No. 28, “Direction of excited-phase signal detection” to the direction opposite to the mechanical end.

 **Warning:** Turning on the servo while the slider or rod is still contacting the mechanical end may disable accurate detection of the excited phase, resulting in malfunction or excitation detection error.

- (6) Connect a PC or teaching pendant and set the minimum parameters required.
 - If the pause input is not used, set parameter No. 15 “Pause input disable selection” to “1.”
 - To select “16 points,” set parameter No. 25 “PIO pattern selection” to “2” or “3.” (This setting is required.)
For details, refer to 8, “Parameter Settings.”
- (7) Cancel the emergency stop so that the motor drive power will be supplied.
 - ★ The controller servo will be turned on and a green LED lamp will illuminate on the motor cover.
- (8) If the pause signal (*STP) is enabled, turn the signal ON from the PLC.
 - ★ The position complete output (PEND) will turn ON.
 - ★ A red LED lamp indicates an alarm. Remove the cause of the alarm.
For details, refer to 9, “Troubleshooting.”
- (9) Perform home return.
 - Overview of operation on the teaching pendant
 - On the RCM-T, select the Edit/Teach screen, bring the cursor to *Home in the sub-display area, and then press the ENTER key.
 - On the RCM-E, select the Teach/Play screen, scroll the pages until *Home Return is shown, and then press the ENTER key.
 - Overview of operation in the PC software
In the main window, select the applicable position data, and then click **Home**.

For details of each operation, refer to the operation manual for the applicable teaching pendant or PC software.

If the actuator does not perform home return, confirm that the *pause signal is ON, the motor-drive power supply is receiving power, and no error messages are displayed, among others.

- (10) Set the target position, speed, acceleration/deceleration, positioning band and other data in the position table. For details on how to set data in the position table, refer to the operation manual for the teaching pendant or PC software, whichever is applicable.
Now, you can operate the actuator automatically via control from the PLC.

⚠ Caution: Issue a command from the PLC after confirming that the position complete output (PEND) is ON.

Timing chart at start

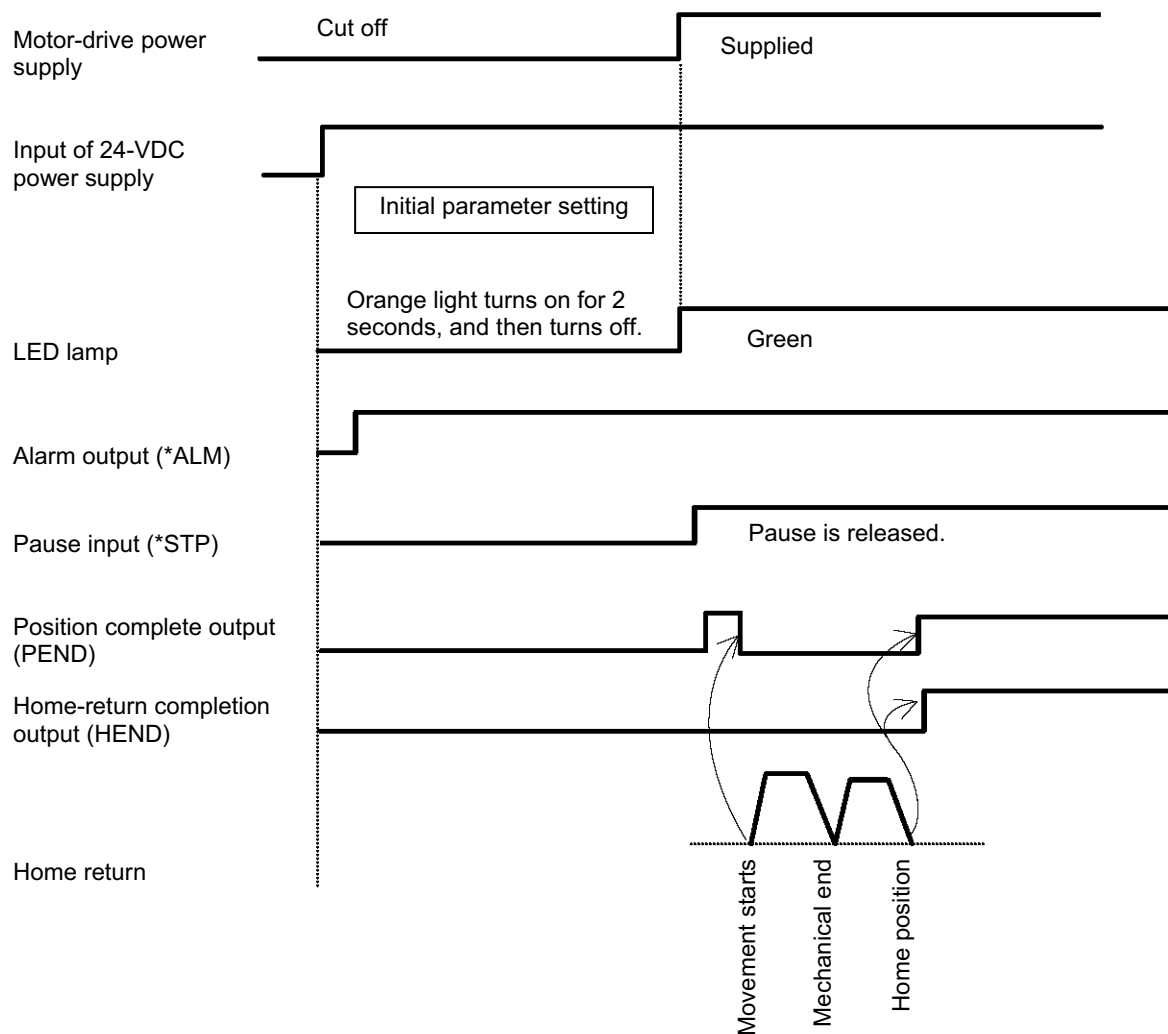

➔ Create a position table via teaching pendant or PC operation.

7.2 Position Table and Parameter Settings Required for Operation

7.2.1 Test Operation

Immediately after the system has been started, the moving speed can be reduced by the methods specified below to ensure safety of operators and prevent damage to jigs, etc.

Change the applicable parameters if necessary.

→ For details on the setting-change operations, refer to the operation manual for your PC software/teaching pendant.

Safety speed during manual feed

Parameter No. 35 defines the feed speed to be applied when the actuator is moved using a PC/teaching pendant.

The factory setting is "100 mm/s." Change this value if necessary.

Take note that the maximum speed is 250 mm/s.

Speed override for movement commands from the PLC

You can lower the feed speed to be applied when the actuator moves based on the movement commands output from the PLC.

To lower the speed to below the level set in the "Speed" field of the position table, you can use parameter No. 46 to override the "Speed" field.

Actual moving speed = [Speed set in the position table] x [Value of parameter No. 46] ÷ 100

Example) Value in the "Speed" field of the position table 500 (mm/s)
 Value of parameter No. 46 20 (%)

Under the above settings, the actual moving speed becomes 100 mm/s.

The minimum setting unit is "1%," while the input range is "1 to 100 %." The factory setting is "100 %."

7.2.2 Full-scale Operation

We provide energy-saving modes to reduce power consumption in situations where the actuator remains standstill for a long period at a standby position.

You can also select the status of position complete signal to be applied if the servo turns off or “position deviation” occurs while the actuator is standing still after completing positioning.

Use these functions after confirming that they will not present problems to any part of your system.

- PIO pattern = 2 or 3 [16 points]

Saving energy when the actuator stands by for a long time after the power has been turned on

In this condition, you can select full servo control using parameter No. 53 (Default standstill mode). (This setting is not affected by the value in the “Standstill mode” field of the position table.)

→ For details, refer to 5.3, “Power-saving Modes at Standby Positions” and 8.2.2, “Parameters Relating to the Actuator Operating Characteristics.”

- PIO pattern = 0 [8 points]

Power saving when the actuator stands by for a long time after the home return effected by the HOME input signal

In this condition, you can select one of two modes based on the value of parameter No. 53, “Default standstill mode.” (This setting is not affected by the value in the “Standstill mode” field of the position table.)

[1] Full servo control

[2] Automatic servo-off control

→ For details, refer to 5.3, “Power-saving Modes at Standby Positions” and 8.2.2, “Parameters Relating to the Actuator Operating Characteristics.”

- Common to all PIO patterns

Saving energy when the actuator stands by for a long time at the target position

In this condition, you can select one of two modes based on the value in the “Standstill mode” field of the position table. (This setting is not affected by the value of parameter No. 53.)

[1] Full servo control

[2] Automatic servo-off control

→ For details, refer to 5.3, “Power-saving Modes at Standby Positions” and 8.2.2, “Parameters Relating to the Actuator Operating Characteristics.”

Output mode of position complete signal

You can select the status of position complete signal to be applied if the servo turns off or “position deviation” occurs while the actuator is standing still after completing positioning.

This setting uses parameter No. 39. Consider the characteristics of the control you need and select an appropriate mode.

→ For details, refer to 8.2.3, “Parameters Relating to the External Interface.”

7.3 How to Execute Home Return

First, force the position complete signal to turn ON by referring to 7.1, “How to Start.”

7.3.1 8 Points

Enter the home return signal (HOME).

When home return is completed, the home return completion signal (HEND) and position complete signal (PEND) will be turned ON.

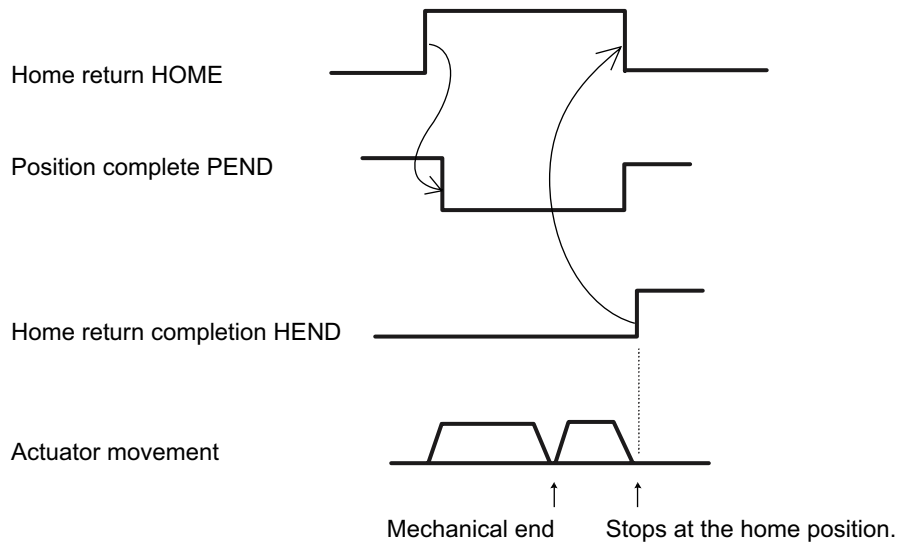

Caution: When the home return signal turns ON, the position complete output will turn OFF. Always turn OFF the home return signal after confirming that the home return completion output has turned ON.

7.3.2 16 Points

Input a start signal after selecting and inputting a desired command position number in which a target position is registered.

Home return is executed first, and then the actuator will move to the target position.

The home return completion signal (HEND) will be turned ON at the home position, and upon reaching the target position the position complete signal (PEND) will be turned ON.

To stop the actuator at the home position, set the target position to "0."

(Example) When "100 mm" is set as the target position in position No. 3, and the home position is not yet established

[Operation under the standard specification]

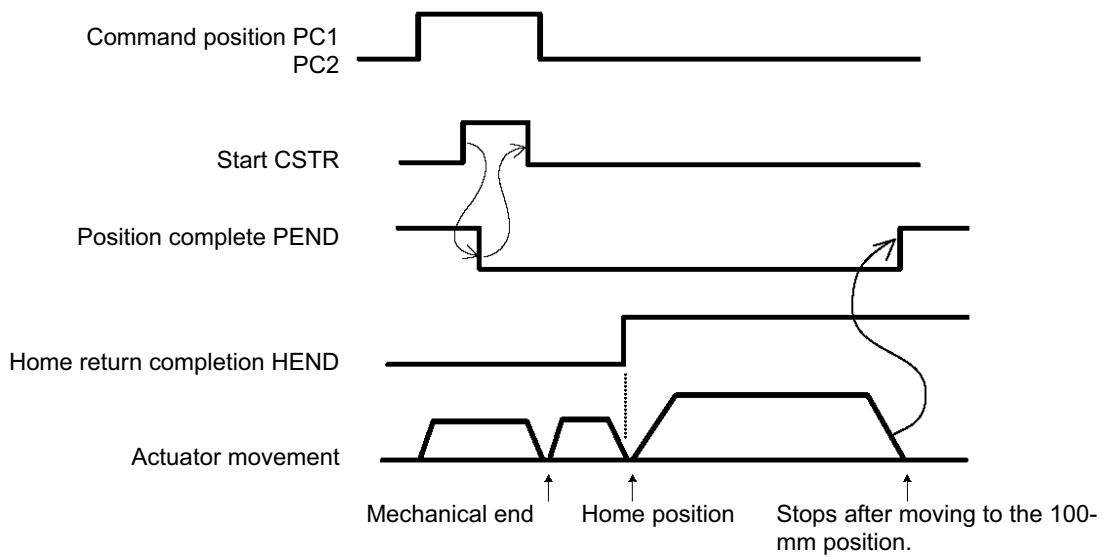

7.4 Home Return and Movement after Start (16 Points)

First, set the necessary data in the position table by referring to 7.1, "How to Start."

If home return has not yet been executed immediately after the system start, issuing a start command by specifying a position will cause the actuator to return to the home before moving to the specified position.

Example of use in operation) Home return is performed after the power ON, followed by positioning to the position 150 mm from the home at a speed of 200 mm/sec.

Position-data table (Field(s) within thick line must be entered.)

No.	Position [mm]	Speed [mm/s]	Acceleration [G]	Deceleration [G]	Push [%]	Positioning band [mm]
0	0.00	100.00	0.30	0.30	0	0.10
1	150.00	200.00	0.30	0.30	0	0.10
⋮						

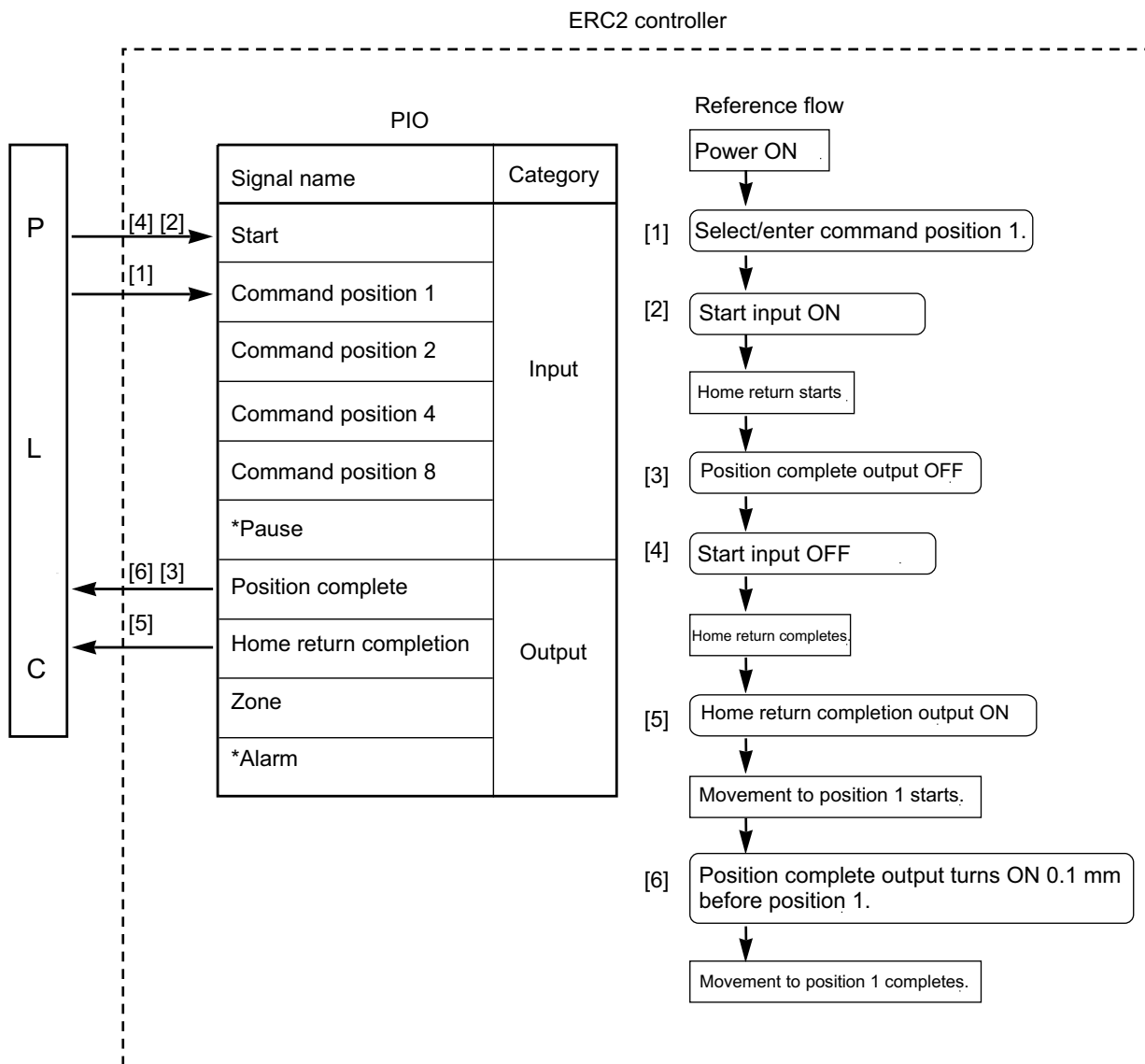

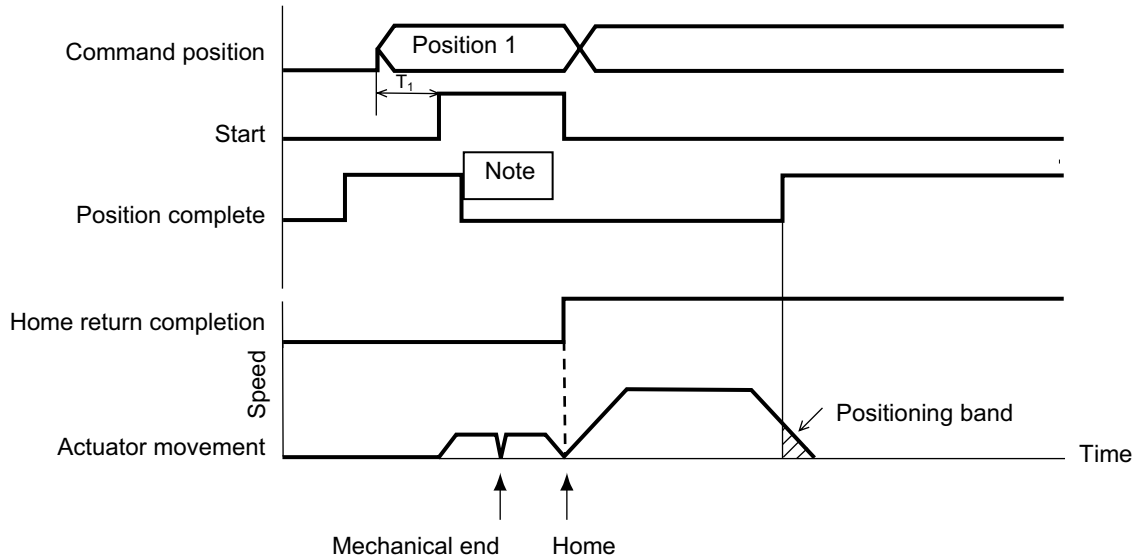

The position complete output will turn ON when the controller becomes ready following the power ON. To check if the controller is ready, always check if the position complete output is ON. The actuator will not operate unless the pause input is turned ON.
T1: 6 msec or more; time after selecting/entering a command position until the start input turns ON (The scan time of the host controller must be considered.)

Caution: [1] When the start signal turns ON, the position complete output will turn OFF. The start signal must be turned OFF with the confirmation that the position complete output has turned OFF while the start signal remains ON. If the start input remains ON as shown below, the position complete output will not turn ON even when the actuator movement is completed.

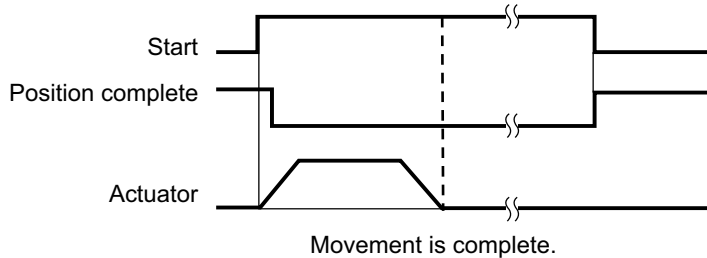

[2] Increasing the positioning band allows the position complete signal to turn ON more quickly, and consequently the next operation in the sequence starts early. This is an effective means for reducing the tact time, so set an optimal value based on the overall balance of your system.

7.5 Positioning Mode (Back and Forth Movement between Two Points)

Example of use in operation) The actuator moves back and forth between two positions. The position 250 mm from the home is set as position 1, and the position 100 mm from the home is set as position 2. The travel speed to position 1 is set as 200 mm/sec, and to position 2 is set as 100 mm/sec.

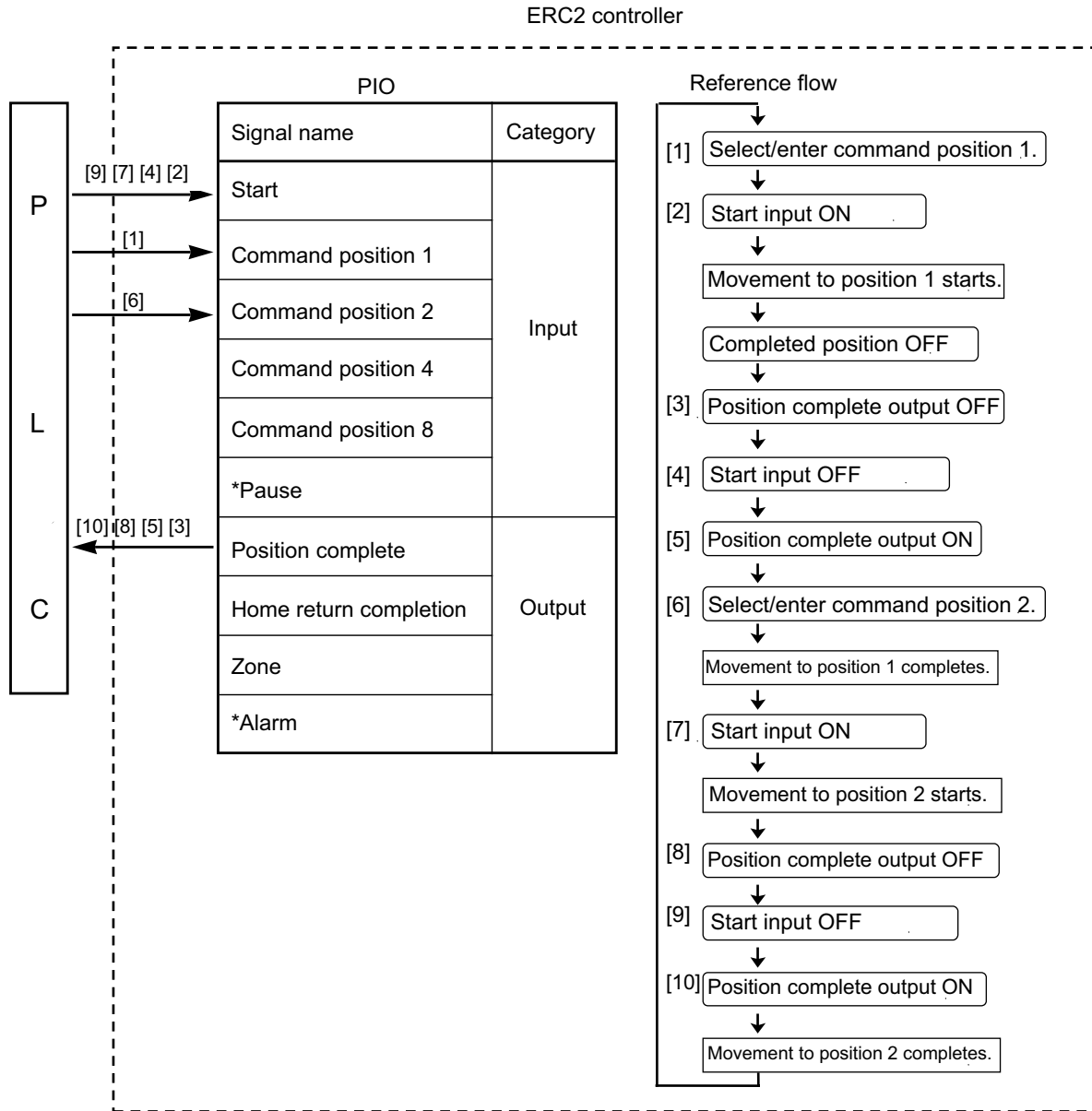

Position-data table (Field(s) within thick line must be entered.)

No.	Position [mm]	Speed [mm/s]	Acceleration [G]	Deceleration [G]	Push [%]	Positioning band [mm]
0	*	*	*	*	*	*
1	250.00	200.00	0.30	0.30	0	0.10
2	100.00	100.00	0.30	0.30	0	0.10
⋮						
⋮						

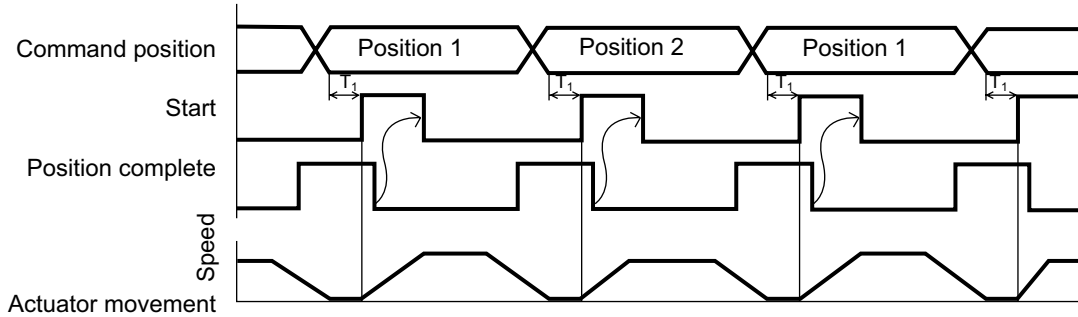

T1: 6 msec or more; time after selecting/entering a command position until the start input turns ON
(The scan time of the host controller must be considered.)

Each command position must be input after the position complete output has turned ON for the movement to the previous position.

Caution: [1] When the start signal turns ON, the position complete output will turn OFF. The start signal must be turned OFF with the confirmation that the position complete output has turned OFF while the start signal remains ON. If the start input remains ON as shown below, the position complete output will not turn ON even when the actuator movement is completed.

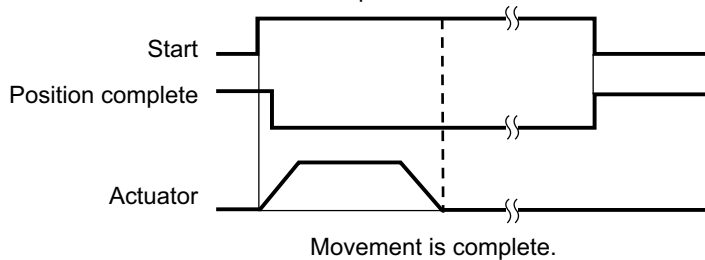

[2] Increasing the positioning band allows the position complete signal to turn ON more quickly, and consequently the next operation in the sequence starts early. This is an effective means for reducing the tact time, so set an optimal value based on the overall balance of your system.

7.6 Push & Hold Mode

First, cause the position complete signal to turn ON by referring to 7.1, "How to Start."

Example of use in operation)

The actuator is caused to move back and forth in the push & hold mode and positioning mode. The position 280 mm from the home is set as position 1, and the position 40 mm from the home is set as position 2. Movement to position 1 is performed in the push & hold mode (the actuator is caused to contact the work part and push it in the counter-motor direction). The maximum push amount at position 1 is set as 15 mm, and the current-limiting value during the push & hold operation by the motor is set as 50%. Movement to position 2 is performed in the positioning mode. The travel speed to position 1 is set as 200 mm/sec, and that to position 2 is set as 100 mm/sec.

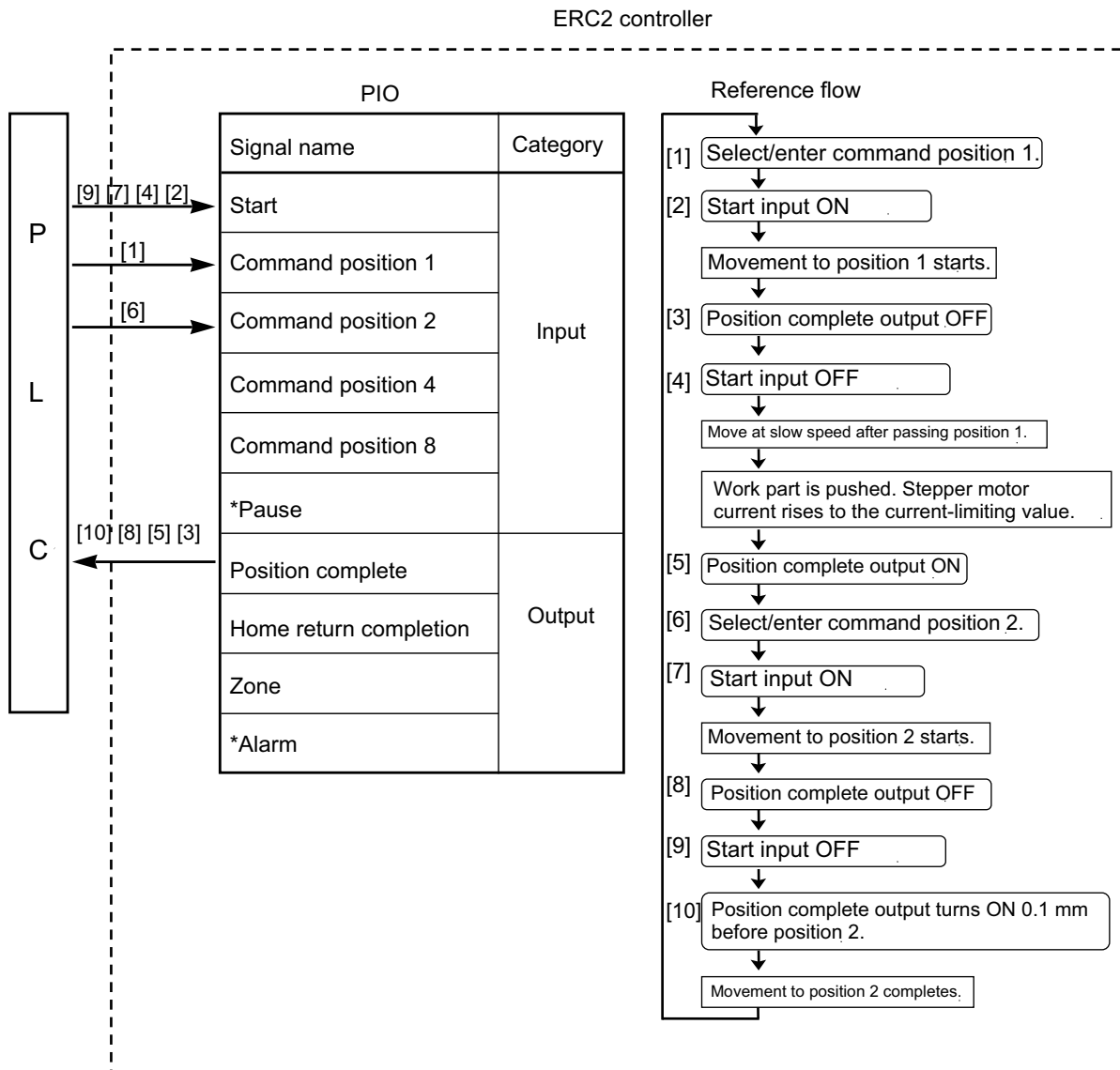

Position-data table (Field(s) within thick line must be entered.)

No.	Position [mm]	Speed [mm/s]	Acceleration [G]	Deceleration [G]	Push [%]	Positioning band [mm]
0	*	*	*	*	*	*
1	280.00	200.00	0.30	0.30	50	15.00
2	40.00	100.00	0.30	0.30	0	0.10
⋮						

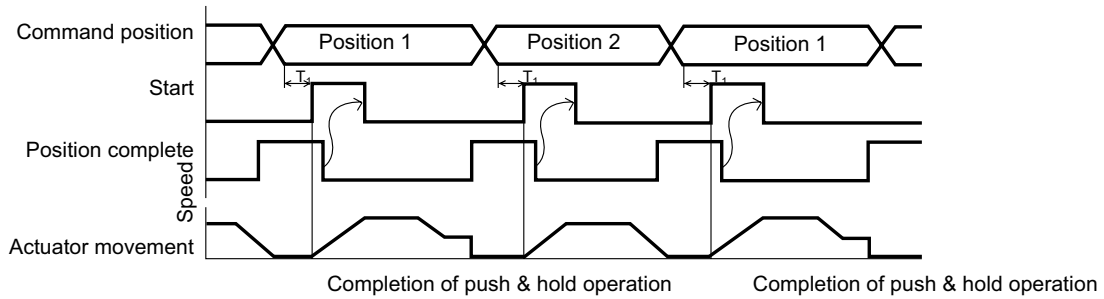

T1: 6 msec or more; time after selecting/entering a command position until the start input turns ON
(The scan time of the host controller must be considered.)

Each command position must be input after the position complete output has turned ON for the movement to the previous position.

● Conditions for determining completion of push & hold operation

Push & hold operation is deemed to have completed upon elapse of the time set by parameter No. 6 (Push completion judgment time) after the motor current reached the current-limiting value set in the “Push” field of the position table.

Set an appropriate value by considering the material and shape of the work part, and so on.

The minimum setting unit is “1 msec,” while the maximum value is “9999 msec.” The factory setting is “255 msec.”

(Note) The chart below explains how completion of push & hold operation is determined if the work part shifted during the judgment and the current has changed as a result, based on a judgment time of 255 msec.

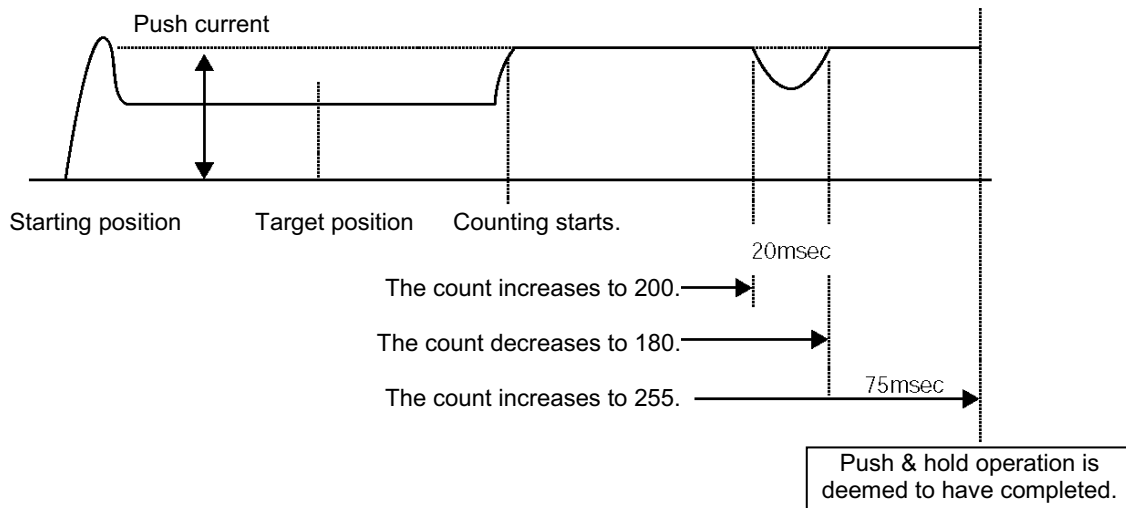

If the motor current remains at or above the push current for 200 msec and then drops below this level for 20 msec, the count will decrease by 20. When the push current is reached again thereafter, counting will start from 180. If the motor current remains at or above the push current for 75 msec, the count will increase to 255 and thus push & hold operation will be deemed to have completed.

In total, 295 msec was required for the judgment.

7.6.1 Notes on Returning in the Incremental Mode after Push & Hold Operation

The reference position to be used when the actuator returns after push & hold operation is different between the positioning mode and the push & hold mode (the work part was missed).

● Positioning mode

The reference position is the target position for the position number used in the applicable push & hold operation. In the aforementioned example, the actuator moves to the 240-mm position if position No. 2 is set to -40 mm in the incremental mode ($280 - 40 = 240$ mm).

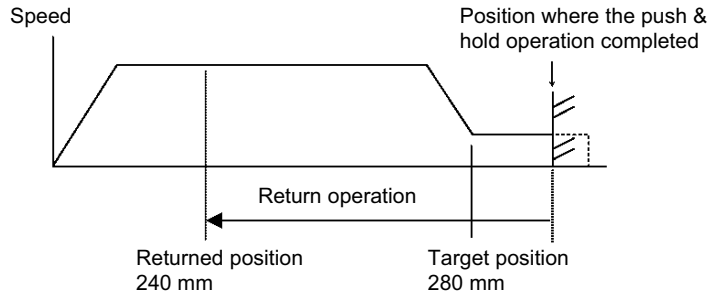

● Push & hold mode

The reference position is the position where the push & hold operation completed.

In the aforementioned example, the actuator moves to the 250.34-mm position if position No. 2 is set to -40 mm in the incremental mode and the push & hold operation completed at 290.34 mm ($290.34 - 40 = 250.34$ mm).

(Note) In this case, the controller determines that the actuator has missed the work part and thus does not turn ON the position complete signal.

It is therefore recommended that the zone output signal be used to determine completion of push & hold operation on the PLC side.

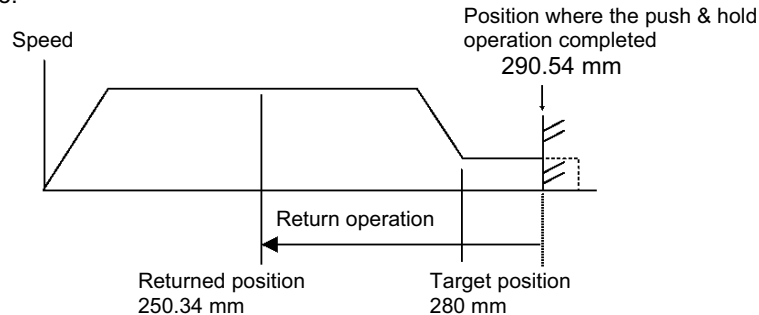

⚠ Caution: When the start signal turns ON, the position complete output will turn OFF. The start signal must be turned OFF with the confirmation that the position complete output has turned OFF while the start signal remains ON. If the actuator has missed the work part, the position complete output will not turn ON as shown below.

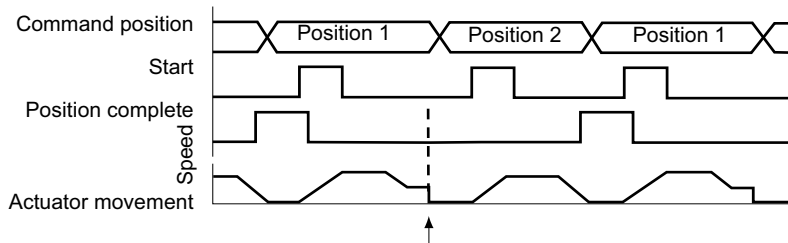

If the actuator has missed the work part, the position complete signal does not turn ON. Therefore, it is recommended that the zone output be used to determine if the final position has been reached.

7.7 Speed Change during Movement

Example of use in operation) The actuator speed is reduced at a certain point during movement. The position 150 mm from the home is set as position 1, and the position 200 mm from the home is set as position 2. The actuator is initially located between the home and position 1. The actuator is moved to position 2 being the target position, at a travel speed of 200 mm/sec to position 1 and that of 100 mm/sec from position 1 to position 2.

Method) In this example, the actuator is caused to move to position 1 and to position 2 successively. Before the actuator is stopped at position 1, command position 2 must be selected/entered and the start signal must be input. To do this, set a wide positioning band at position 1 and cause the start signal for movement to position 2 to be input immediately after the completion signal for movement to position 1 is output. (Command position 2 should be entered while the actuator is moving to position 1.)

ERC2 controller

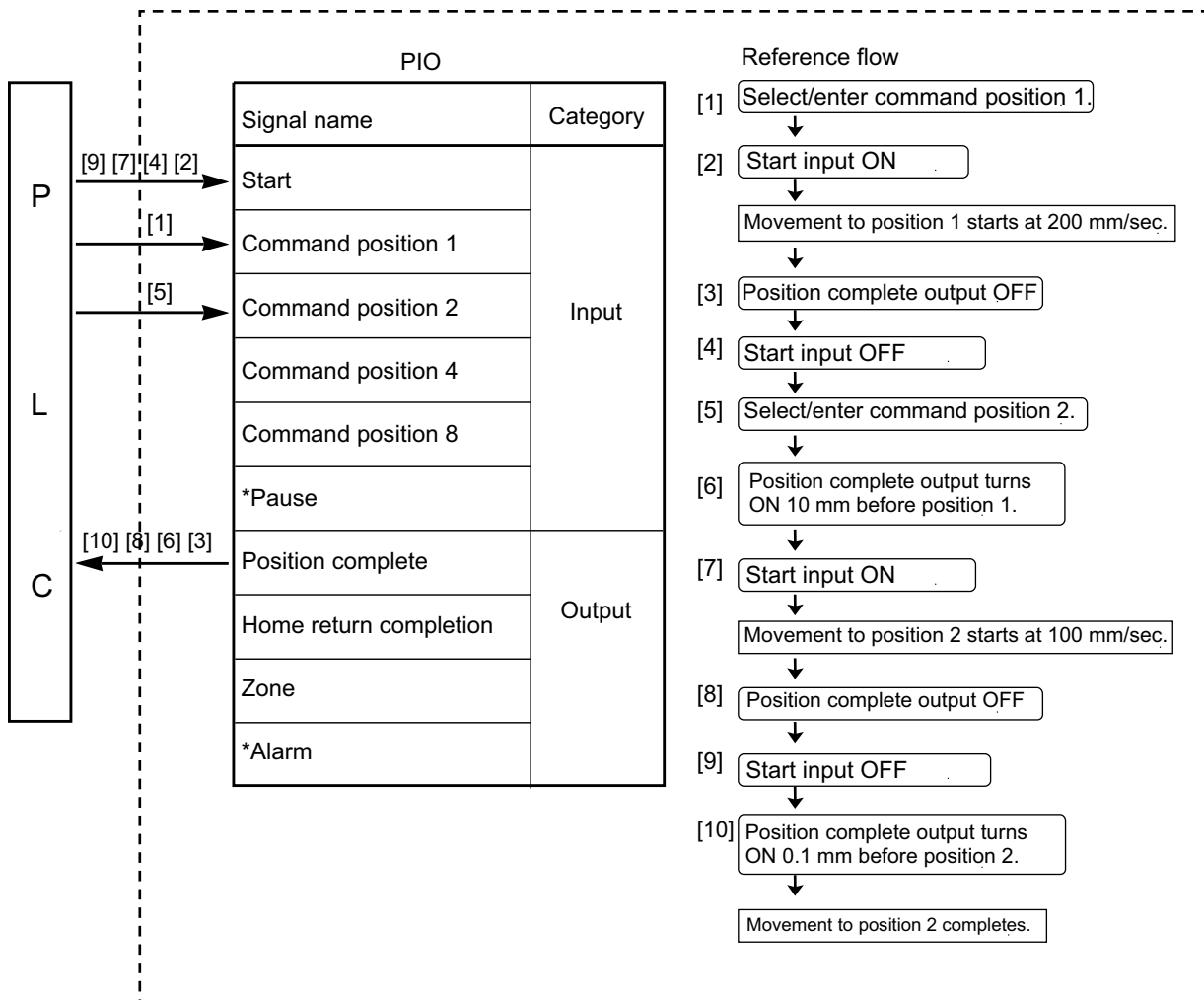

Position-data table (Field(s) within thick line must be entered.)

No.	Position [mm]	Speed [mm/s]	Acceleration [G]	Deceleration [G]	Push [%]	Positioning band [mm]
0	*	*	*	*	*	*
1	150.00	200.00	0.30	0.30	0	10.00
2	200.00	100.00	0.30	0.30	0	0.10
⋮						

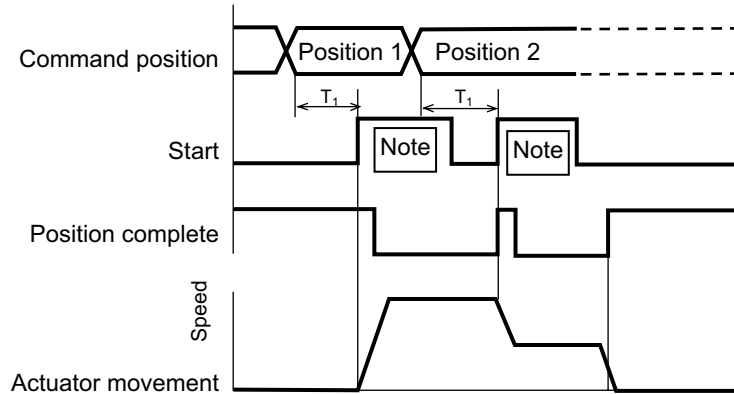

T1: 6 msec or more; time after selecting/entering a command position until the start input turns ON
(The scan time of the host controller must be considered.)

Caution: When the start signal turns ON, the position complete output will turn OFF. The start signal must be turned OFF with the confirmation that the position complete output has turned OFF while the start signal remains ON.

7.8 Operation at Different Acceleration and Deceleration Settings

In applications where the work part or peripheral equipment should not receive impact or vibration when the actuator is standing still, you can apply a gradual curve only during deceleration.

Example of use in operation) Move the actuator from the home to the 150-mm position (position 1) at a speed of 200 mm/sec. The acceleration and deceleration are to be 0.3 G and 0.05 G, respectively.

Method) Set "0.3" G in the "Acceleration" field and "0.05" G in the "Deceleration" field of the position table.

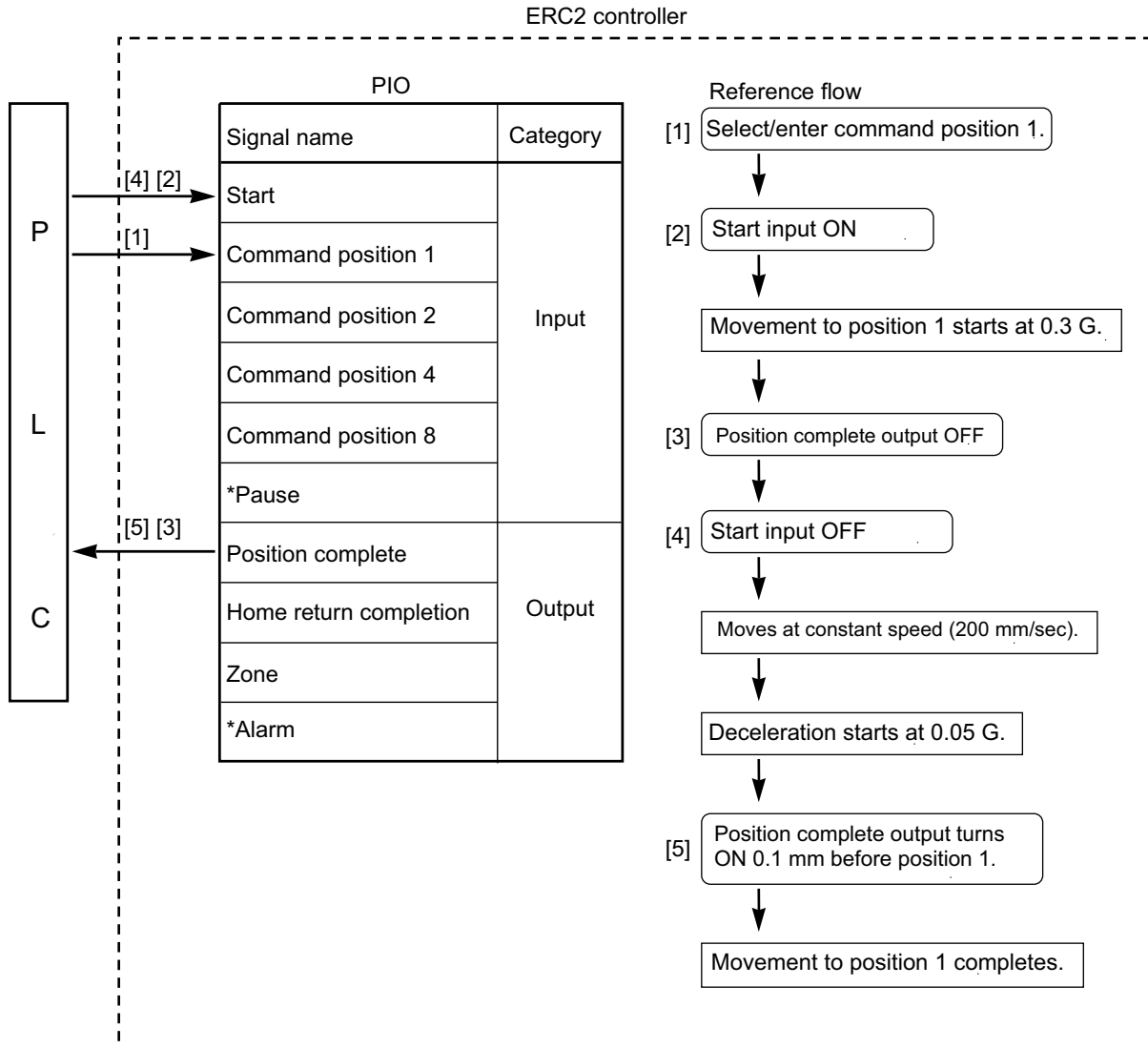

Position-data table (Field(s) within thick line must be entered.)

No.	Position [mm]	Speed [mm/s]	Acceleration [G]	Deceleration [G]	Push [%]	Positioning band [mm]
0	*	*	*	*	*	*
1	150.00	200.00	0.30	0.05	0	0.10
⋮						

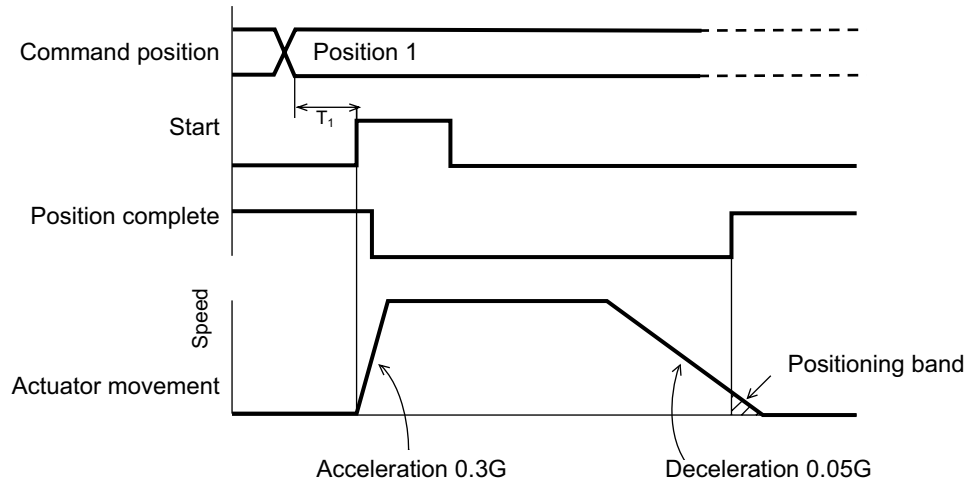

T1: 6 msec or more; time after selecting/entering a command position until the start input turns ON (The scan time of the host controller must be considered.)

Caution: When the start signal turns ON, the position complete output will turn OFF. The start signal must be turned OFF with the confirmation that the position complete output has turned OFF while the start signal remains ON. If the start input remains ON as shown below, the position complete output will not turn ON even when the actuator movement is completed.

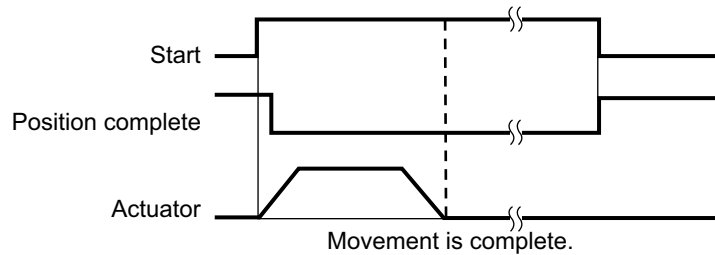

7.9 Pause

Example of use in operation) The actuator is paused during movement.
 Method) Use the pause input.

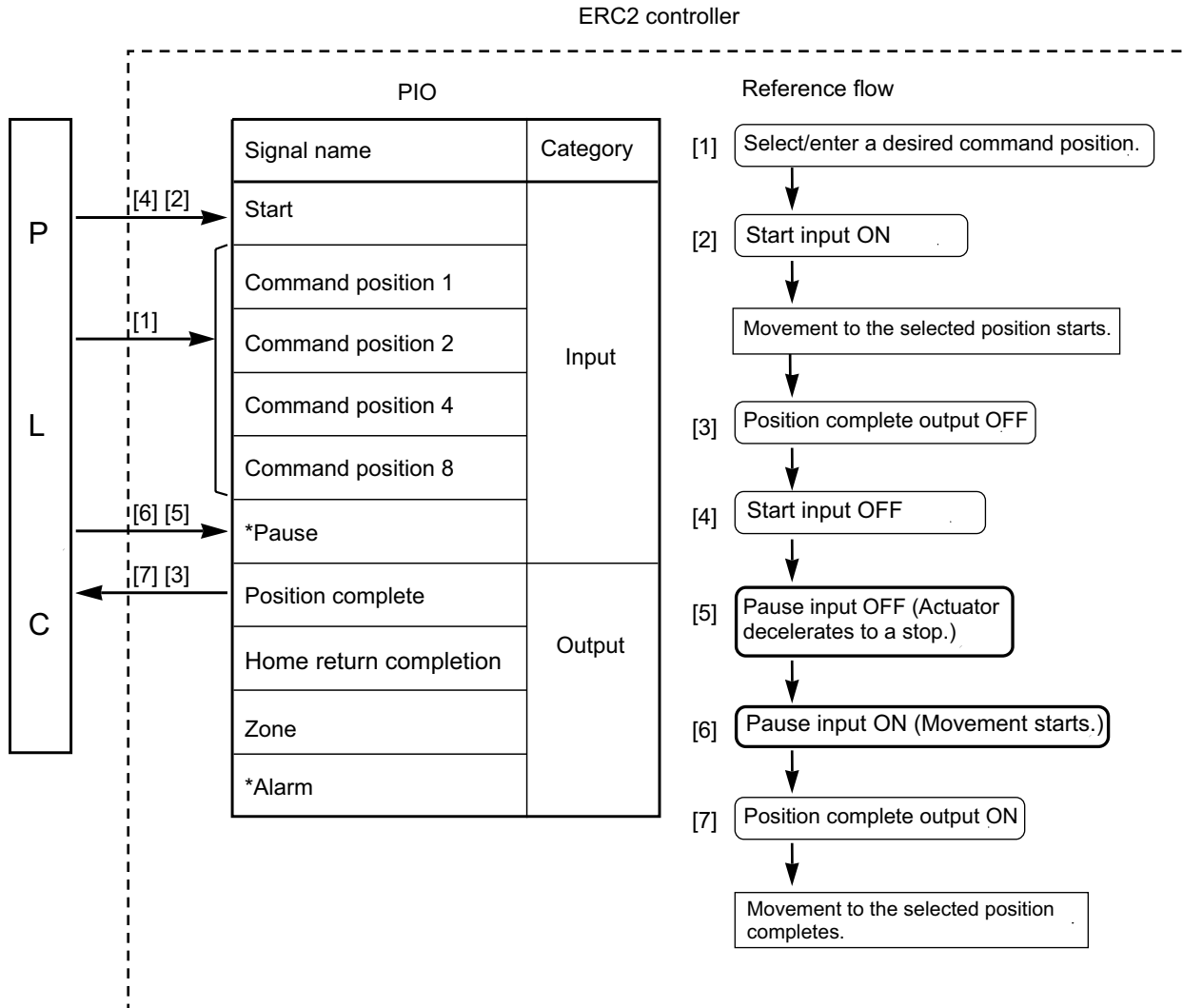

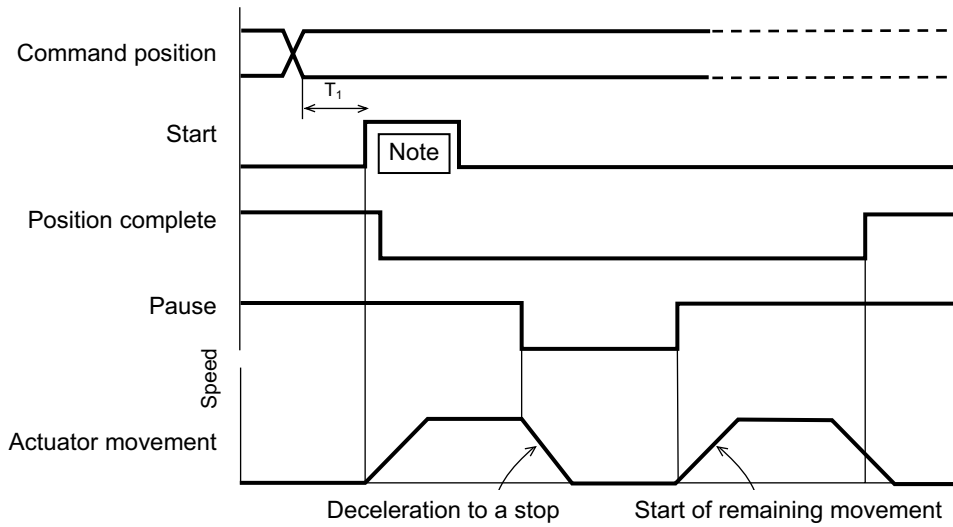

T1: 6 msec or more; time after selecting/entering a command position until the start input turns ON
(The scan time of the host controller must be considered.)

Caution: When the start signal turns ON, the position complete output will turn OFF. The start signal must be turned OFF with the confirmation that the position complete output has turned OFF while the start signal remains ON.

7.10 Zone Signal

How the boundaries are set varies depending on the PIO pattern.

- If fixed boundaries are applied to all operations, set them using parameters. (PIO pattern = 0 or 2).
- To set different boundaries for each position number to support multiple loads, set respective settings in the position table. (PIO pattern = 3)

Example of use in operation) Output a zone signal in a range of 40 to 120 mm while the actuator is moving from the home to the 150-mm position (position 1).

- Method)
- PIO pattern = 0 or 2
Use the parameters "Zone boundary+" and "Zone boundary-" to set the zone in which the zone signal is output, as shown below:

Parameter No. 1	Zone boundary+	120 (mm)
Parameter No. 2	Zone boundary-	40 (mm)

- PIO pattern = 3
Use the "Zone+" and "Zone-" fields of the position table to set the zone in which the zone signal is output, as shown below:

No.	Position [mm]	Zone+ [mm]	Zone- [mm]
0	*	*	*
1	150.00	120.00	40.00
⋮			

ERC2 controller

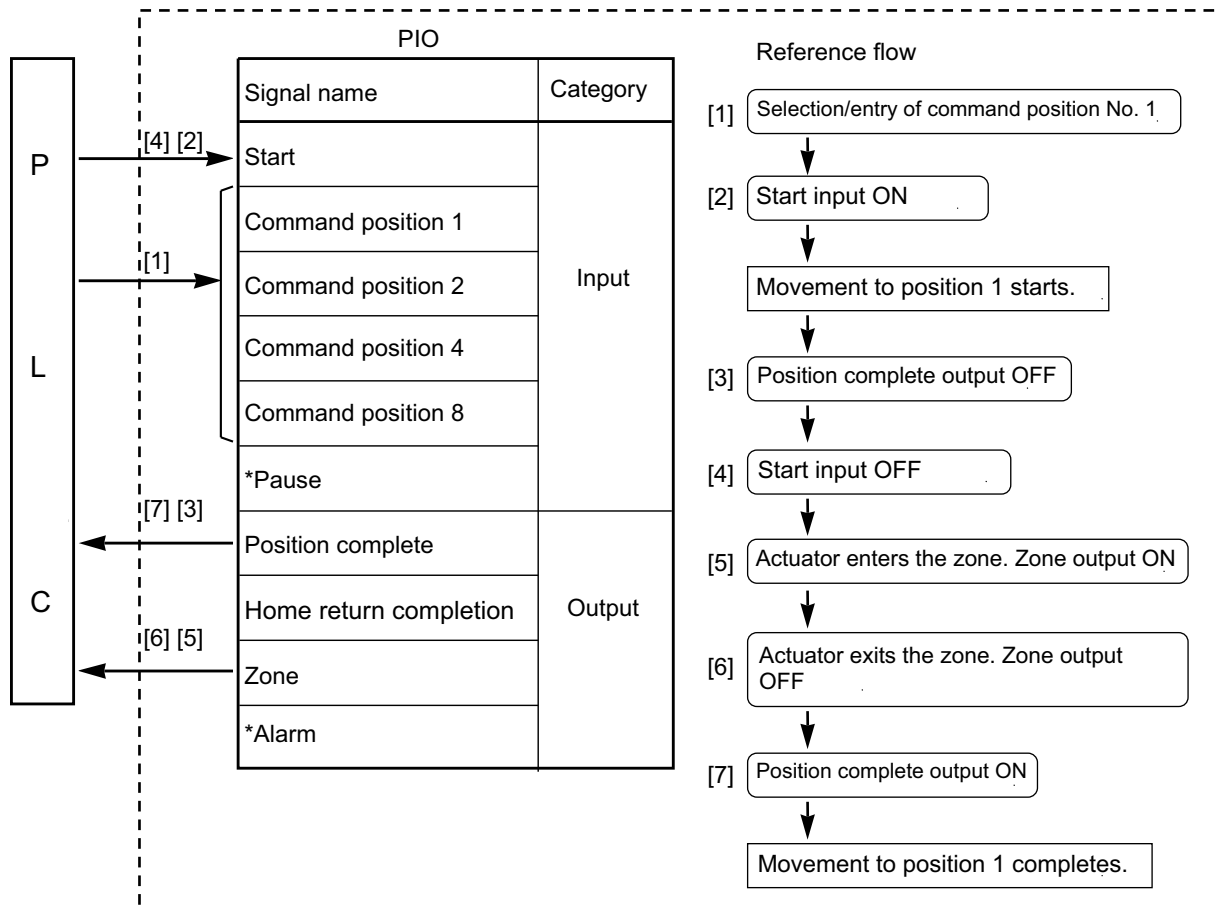

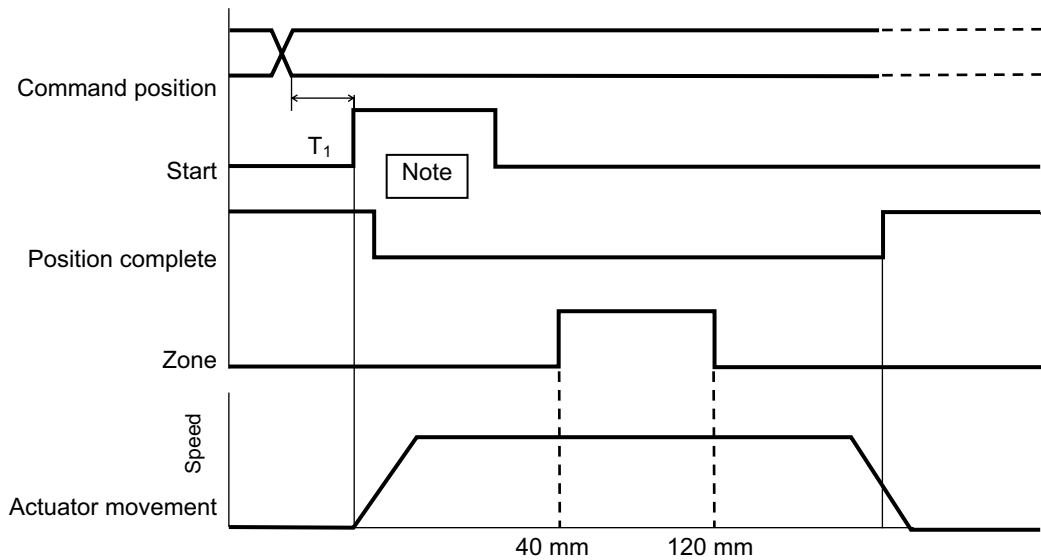

T1: 6 msec or more; time after selecting/entering a command position until the start input turns ON (The scan time of the host controller must be considered.)

Caution: When the start signal turns ON, the position complete output will turn OFF. The start signal must be turned OFF with the confirmation that the position complete output has turned OFF while the start signal remains ON.

Example of other zone output)

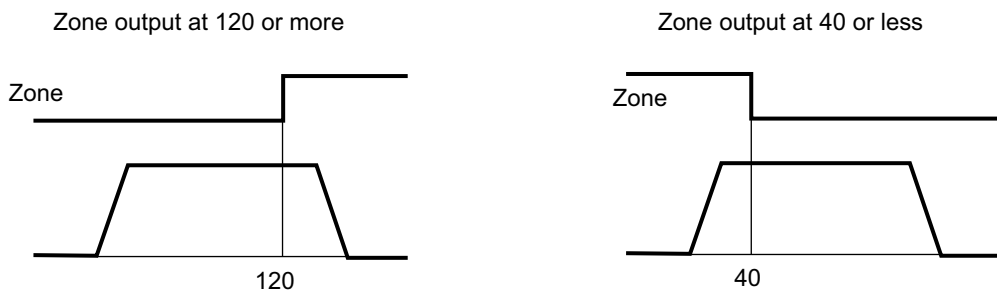

Zone boundary+	Maximum stroke length
Zone boundary-	120

Zone boundary+	40
Zone boundary-	0

7.11 Incremental Moves

Example of use in operation) Move the actuator from the home to the 30-mm position (position No. 1) set in the absolute mode, and then move the actuator further through continuous incremental moves at a 10-mm pitch until the final position of 200 mm is reached. (Pitch feed is specified by position No. 2.)

ERC2 controller

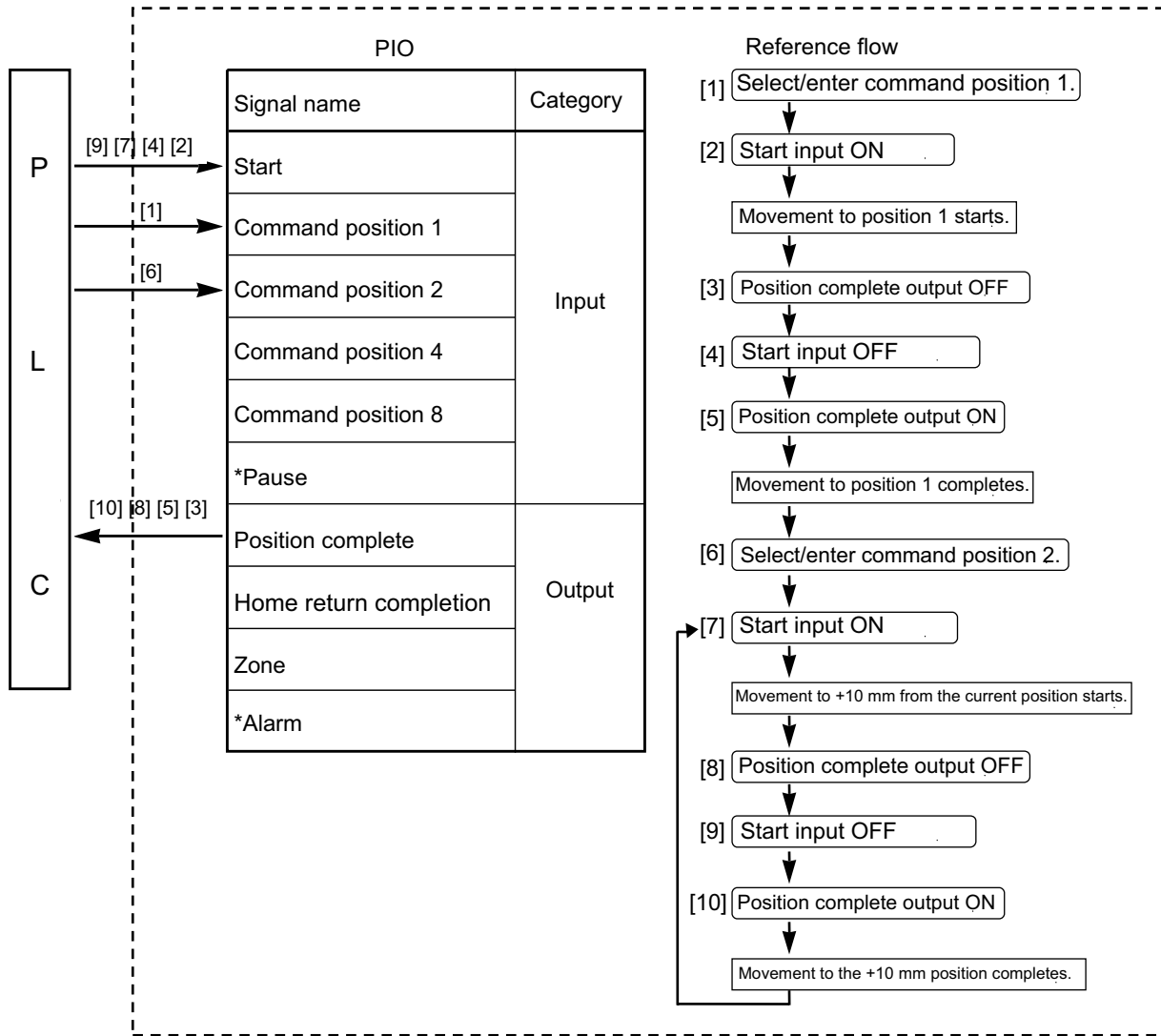

Position-data table (Field(s) within thick line must be entered.)

No.	Position [mm]	Speed [mm/s]	Positioning band [mm]	Zone+ [mm]	Zone- [mm]	Incremental
0	*	*	*	*	*	*
1	30.00	100.00	0.10	0	0	0
2	10.00	20.00	0.10	190.50	29.50	1

Incremental moves

* On the teaching pendant screen, this sign indicates that the position is specified in the incremental mode.

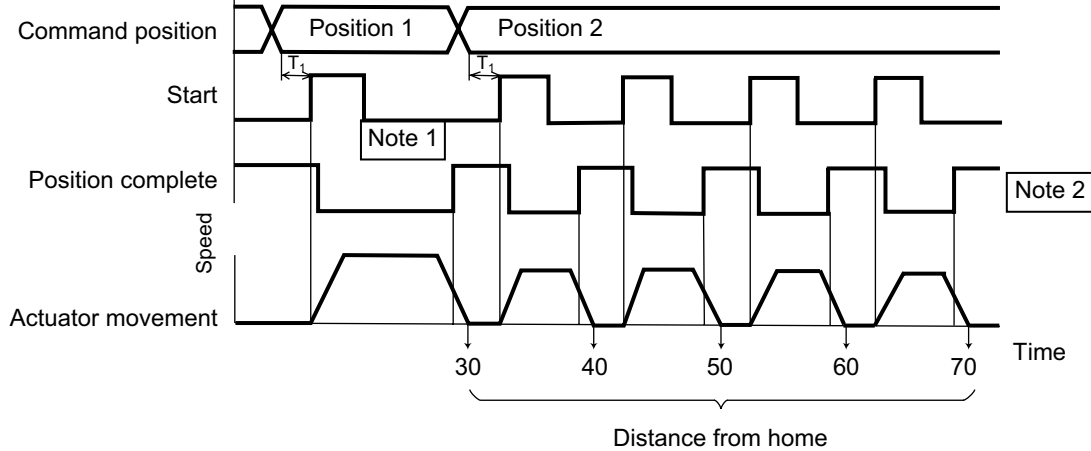

T1: 6 msec or more; time after selecting/entering a command position until the start input turns ON (The scan time of the host controller must be considered.)

Note 1: When the start signal turns ON, the position complete output will turn OFF. The start signal must be turned OFF with the confirmation that the position complete output has turned OFF while the start signal remains ON. If the start input remains ON as shown below, the position complete output will not turn ON even when the actuator movement is completed.

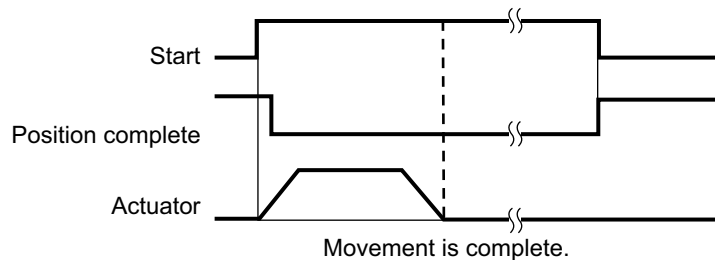

Note 2: When a soft limit is reached as a result of repeated incremental moves, the actuator will stop at that position and the position complete signal will be output.

7.11.1 How to Determine the Final Position

The PLC manages the number of movements to determine the end of positioning. To be doubly sure, the zone output signal can also be used concurrently.

Set the PLC so that it checks the ON/OFF status of the zone output signal upon completion of positioning, and determines, if the signal is OFF, that the last work part has been reached.

If the count in the PLC does not match the status of the zone output signal, signal timings may not be synchronized.

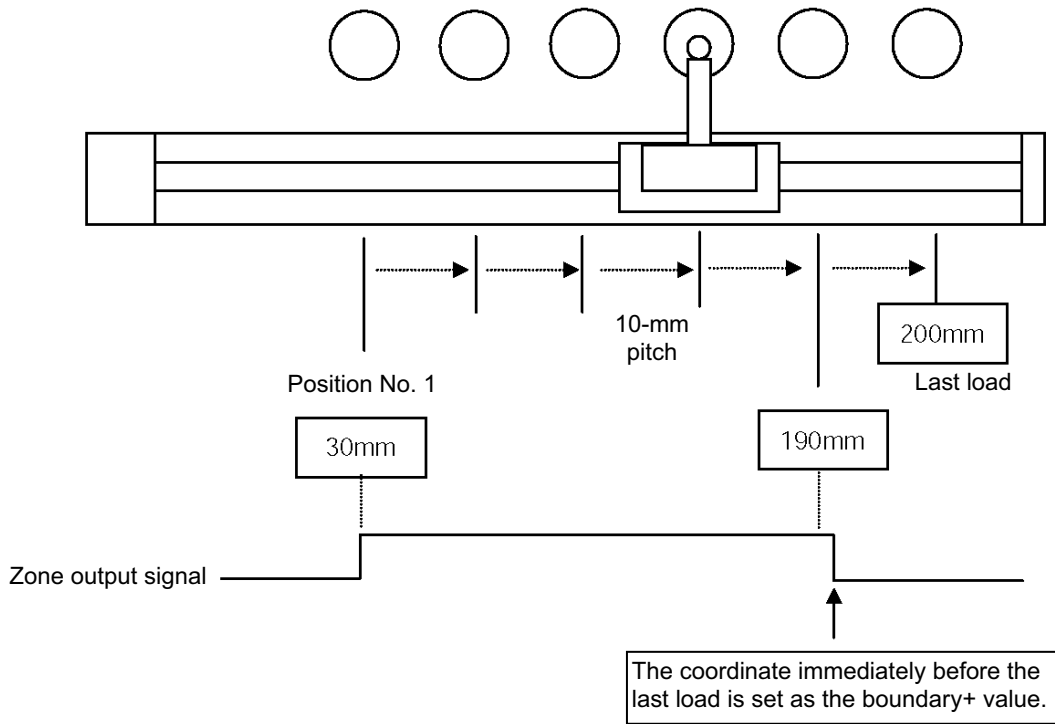

7.12 Notes on Incremental Mode

(1) Positioning mode

Selecting/entering a position number in the incremental mode during positioning will cause the actuator to move to the position corresponding to the initial position plus the increment.

(If the increment is a negative value, the actuator will move to the position corresponding to the initial position minus the increment.)

Example) If the start signal for movement to position 2 is input while the actuator is moving to position 1, the actuator will move to the position 215 mm from the home.

Position-data table (Field(s) within thick line must be entered.)

No.	Position [mm]	Speed [mm/s]	Positioning band [mm]	Push & hold [%]	Incremental
0	*	*	*	*	*
1	200.00	100.00	0.10	0	0
2	= 15.00	20.00	0.10	0	1
⋮					

Incremental moves

* On the teaching pendant screen, this sign indicates that the position is specified in the incremental mode.

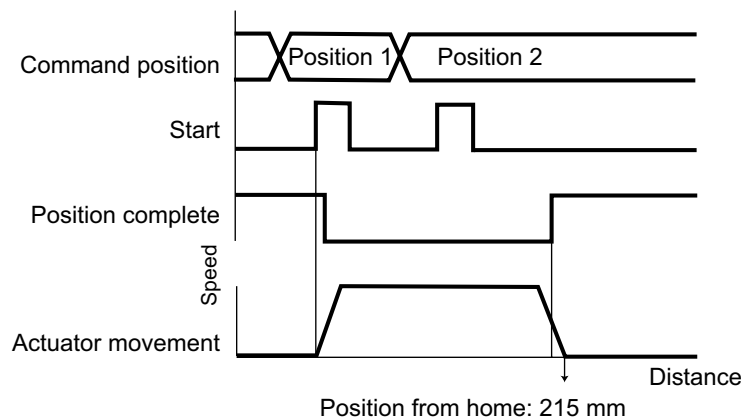

If the start signal for movement to an incremental position number is input multiple times during positioning, the actuator will move to the position corresponding to the initial position plus the “increment x number of times the signal was input.”

Example) If the start signal for movement to position 2 is input twice while the actuator is moving to position 1, the actuator will move to the position 230 mm from the home.

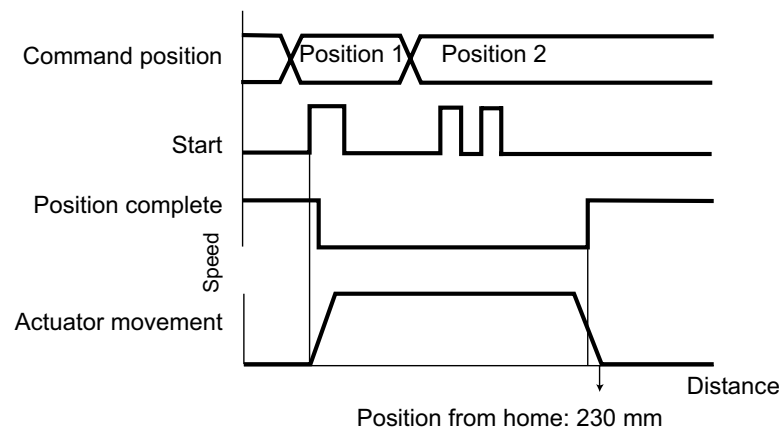

(2) Push & hold mode

The following explains how the actuator will behave when a start signal is input after selecting/entering a position number in the incremental mode while the actuator is moving in the push & hold mode.

● Positioning to the position number set in the incremental mode

Example) If a start signal is input to initiate positioning to position 2 while the actuator is moving to position 1, the actuator will move to the position corresponding to the target position for position 1 plus the increment. If the position table is set as shown below, the actuator will move to the 215-mm position.

Position-data table (Field(s) within thick line must be entered.)

No.	Position [mm]	Speed [mm/s]	Positioning band [mm]	Push & hold [%]	Incremental
0	*	*	*	*	*
1	200.00	100.00	30.00	50	6
2	= 15.00	20.00	0.10	0	1
⋮					

Incremental moves

* On the teaching pendant screen, this sign indicates that the position is specified in the incremental mode.

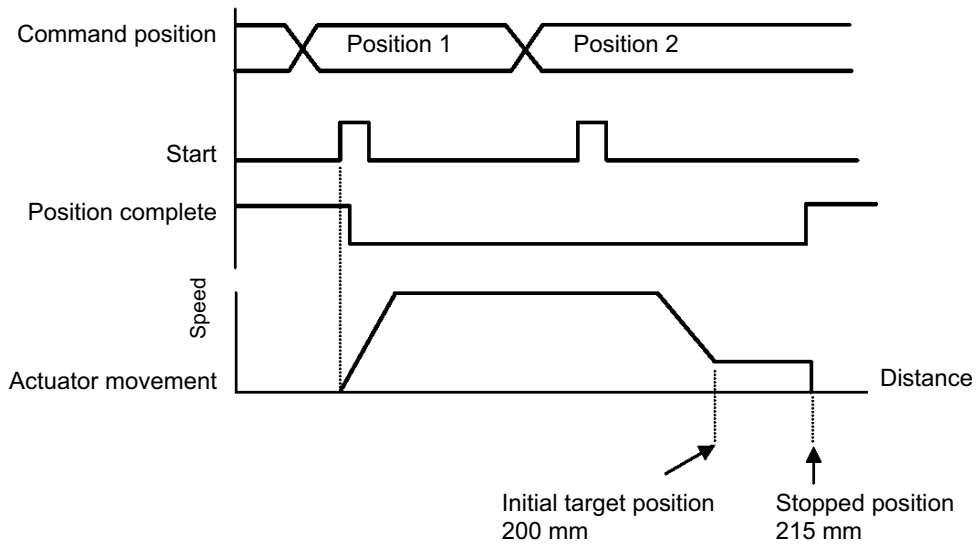

- Moving in the push & hold mode to the position number set in the incremental mode

Example) If a start signal is input to initiate positioning to position 2 while the actuator is moving to position 1, the actuator will move to a new target position, which is determined by adding the increment to the position at which the start input was received.

Since the target position is indeterminable, never use this method.

Position-data table (Field(s) within thick line must be entered.)

No.	Position [mm]	Speed [mm/s]	Positioning band [mm]	Push & hold [%]	Incremental
0	*	*	*	*	*
1	200.00	100.00	30.00	50	0
2	= 15.00	20.00	60.00	50	1
⋮					

Incremental moves

* On the teaching pendant screen, this sign indicates that the position is specified in the incremental mode.

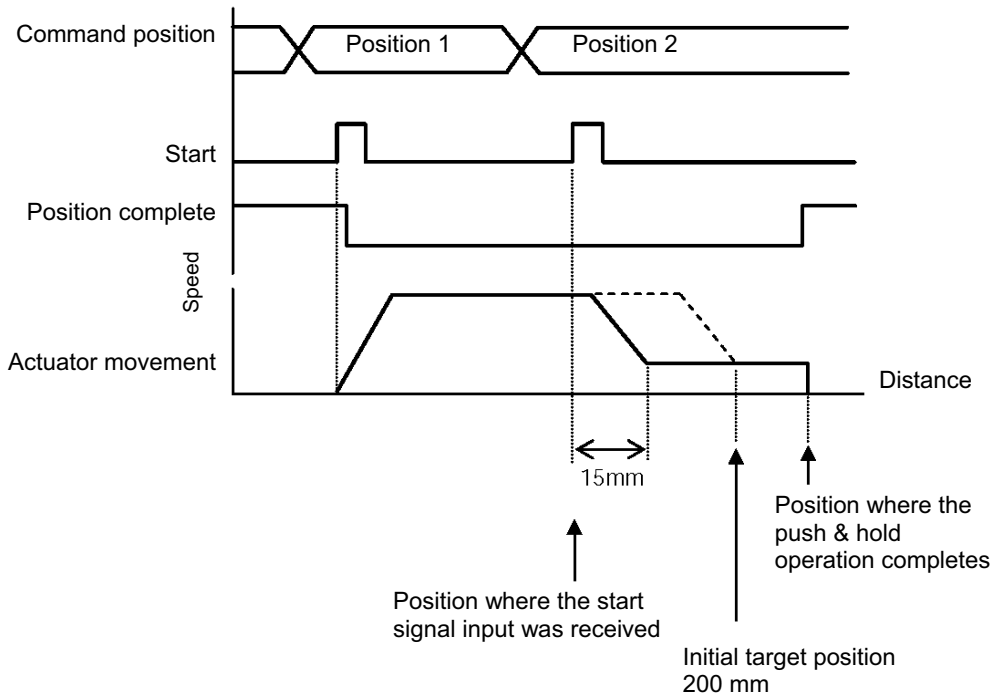

8. Parameter Settings

8.1 Parameter Table

Parameters are classified into four types according to their content.

- Category:
- a: Parameter relating to the actuator stroke range
 - b: Parameter relating to the actuator operating characteristics
 - c: Parameter relating to the external interface
 - d: Servo gain adjustment

No.	Category	Name	Unit	Default factory setting
1	a	Zone boundary 1+	mm	Effective actuator length
2	a	Zone boundary 1-	mm	Effective actuator length
3	a	Soft limit+	mm	Effective actuator length
4	a	Soft limit-	mm	Effective actuator length
5	a	Home return direction (0: [Reverse]/1: [Forward])	-	(In accordance with the specification at the time of order)
6	b	Push & hold stop judgment period	msec	255
7	d	Servo gain number	-	Set individually in accordance with the actuator characteristics.
8	b	Default speed	mm/sec	Set individually in accordance with the actuator characteristics.
9	b	Default acceleration/deceleration	G	Set individually in accordance with the actuator characteristics.
10	b	Default positioning band (in-position)	mm	0.10
12	b	Current-limiting value at standstill during positioning	%	Set individually in accordance with the actuator characteristics.
13	b	Current-limiting value during home return	%	Set individually in accordance with the actuator characteristics.
15	c	Pause input disable selection (0: [Enable]/1: [Disable])	-	0 [Enable]
16	c	SIO communication speed	bps	38400
17	c	Minimum delay time for slave transmitter activation	msec	5
22	a	Home return offset	mm	Set individually in accordance with the actuator characteristics.
25	c	PIO pattern selection	-	0 (8 points)
27	c	Movement command type (0: [Level]/1: [Edge])	-	0 [Level]
28	b	Default direction of excited-phase signal detection (0: [Reverse]/1: [Forward])	-	Set individually in accordance with the actuator characteristics.
29	b	Excited-phase signal detection time	msec	Set individually in accordance with the actuator characteristics.
31	d	Speed loop proportional gain	-	Set individually in accordance with the actuator characteristics.
32	d	Speed loop integral gain	-	Set individually in accordance with the actuator characteristics.
33	d	Torque filter time constant	-	Set individually in accordance with the actuator characteristics.
34	b	Push speed	mm/sec	Set individually in accordance with the actuator characteristics.
35	b	Safety speed	mm/sec	100
36	b	Automatic servo-off delay time 1	sec	0
37	b	Automatic servo-off delay time 2	sec	0
38	b	Automatic servo-off delay time 3	sec	0
39	c	Output mode of position complete signal (0: [PEND]/1: [INP])	-	0 [PEND]
40	c	Home-return input disable selection (0: [Enable]/1: [Disable])	-	0 [Enable]
45	c	Silent interval multiplication factor	times	0 (Multiplication factor is not applied)
46	b	Speed override	%	100
53	b	Default standstill mode	-	0 [Complete stop]

(Note) The numbers are displayed in the PC software, but not on the teaching pendant.

Skipped numbers are not used and therefore omitted.

The classification codes are provided for the sake of convenience and are not displayed either in the PC software or on the teaching pendant.

8.2 Detailed Explanation of Parameters

If a parameter has been changed, always restart the controller using a software reset command or by reconnecting the power.

8.2.1 Parameters Relating to the Actuator Stroke Range

- Soft limit

Set the soft limit in the positive direction in parameter No. 3, and that in the negative direction in parameter No. 4. The factory setting for the soft limits conforms to the effective actuator length. Change the settings, as necessary, to prevent crash with an obstacle or when the actuator must be stroked slightly beyond its effective length.

A wrong soft limit setting will cause the actuator to crash into the mechanical end, so exercise due caution.

The minimum setting unit is "0.01 [mm]."

(Note) To change a soft limit, set a value corresponding to 0.3 mm outside of the effective range.

Example) Set the effective range to between 0 mm and 80 mm

Parameter No. 3 (positive side) 80.3

Parameter No. 4 (negative side) -0.3

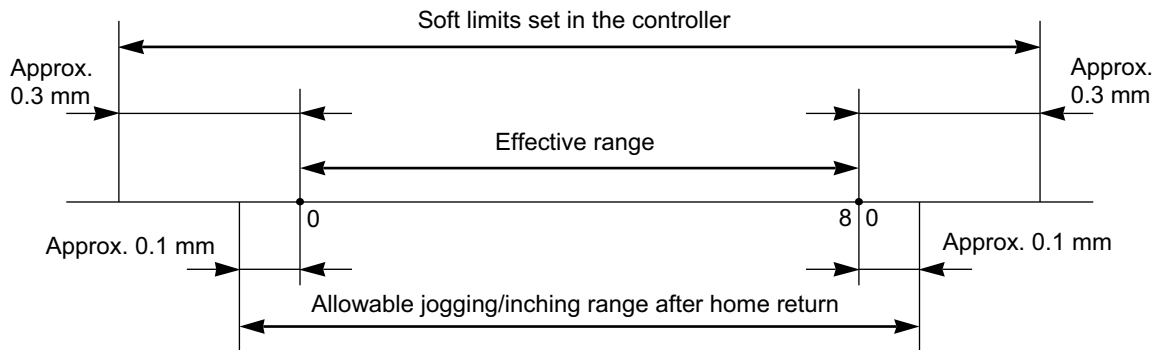

- Home return direction

Unless specified by the user, the home return direction is set to the motor direction at the factory.

Should a need arise to change the home direction after the actuator has been assembled into your system, reverse the setting in parameter No. 5 between "0" and "1."

If necessary, also change the parameters for home return offset, soft limits and direction of excited-phase signal detection.

Caution: The home cannot be set on the opposite side for rod-type actuators.

● Home return offset

The controller is shipped from the factory with an optimal value set in parameter No. 22, so the distance from each mechanical end to the home becomes uniform.

The minimum setting unit is "0.01 [mm]."

The home return offset can be adjusted in the following conditions:

- [1] Want to align the actuator home and the system's mechanical home after the actuator has been assembled into the system
- [2] Want to set a new home after reversing the factory-set home direction
- [3] Want to eliminate a slight deviation generated after replacing the actuator

⚠ Caution: If the home return offset has been changed, the soft limit parameters must also be adjusted accordingly.

● Zone boundary

These parameters apply when the PIO pattern is 0 or 2, and set the zone in which the zone output signal (ZONE) turns ON.

The zone output signal turns ON when the current position is inside the negative (-) boundary and positive (+) boundary settings.

Set the + boundary in parameter No. 1 and - boundary in parameter No. 2.

The minimum setting unit is "0.01 [mm]."

Example) Turn ON the zone output signal in a range of 100 to 200 mm with the actuator having a 300-mm stroke
Parameter No. 1 (+) 200, parameter No. 2 (-) 100

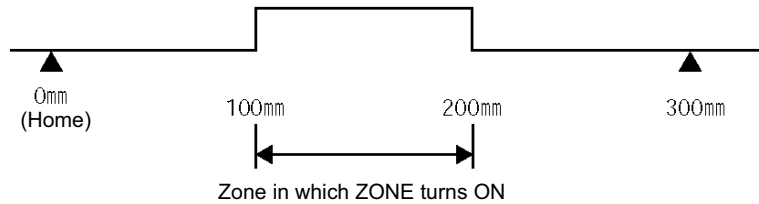

8.2.2 Parameters Relating to the Actuator Operating Characteristics

- Default speed

The factory setting is the rated speed of the actuator.

When a target position is set in an unregistered position table, the setting in this parameter will be used as the speed data for the applicable position number.

To reduce the default speed from the rated speed, change the setting in parameter No. 8.

- Default acceleration/deceleration

The factory setting is the rated acceleration/deceleration of the actuator.

When a target position is set in an unregistered position table, the setting in this parameter will be used as the acceleration/deceleration data for the applicable position number.

To reduce the default acceleration/deceleration from the rated acceleration/deceleration, change the setting in parameter No. 9.

- Default positioning band (in-position)

The factory setting is "0.10 [mm]."

When a target position is set in an unregistered position table, the setting in this parameter will be used as the positioning band data for the applicable position number.

Increasing the default positioning band will allow the position complete signal to be output early. Change the setting in parameter No. 10, as necessary.

- Current-limiting value during home return

The factory setting conforms to the standard specification of the actuator.

Increasing this setting will increase the home return torque.

This setting need not be changed in normal conditions of use. However, if an increased slide resistance causes the home return to complete before the correct position depending on the affixing method, load condition or other factor when the actuator is used in a vertical application, the value set in parameter No. 13 must be increased.

(Do not increase the value beyond 75%.)

- Current-limiting value at standstill during positioning

The factory setting conforms to the standard specification of the actuator.

Increasing this setting will increase the holding torque at standstill.

This setting need not be changed in normal conditions of use. However, to prevent hunting caused by large external force applied while the actuator is at standstill, the value set in parameter No. 12 must be increased.

(Do not increase the value beyond 70%.)

- Speed override

Use this parameter when moving the actuator at a slower speed to prevent danger when the system is initially started for test operation.

When movement commands are issued from the PLC, the moving speed set in the "Speed" field of the position table can be overridden by the value set in parameter No. 46.

Actual moving speed = [Speed set in the position table] x [Value of parameter No. 46] ÷ 100

Example) Value in the "Speed" field of the position table 500 (mm/s)
 Value of parameter No. 46 20 (%)

Under the above settings, the actual moving speed becomes 100 mm/s.

The minimum setting unit is "1 [%]," while the input range is "1 to 100 [%]." The factory setting is "100 [%]."

(Note) This parameter is ignored for movement commands from the PC and teaching pendant.

- Default direction of excited-phase signal detection

When the servo is turned on for the first time after a power on, excited phase is detected. This parameter defines the direction of this detection.

The parameter need not be changed in normal conditions. In certain situations, such as when the actuator was contacting a mechanical end or obstacle when the power was turned on and cannot be moved by hand, change the direction that allows the motor to operate smoothly.

To do this, set parameter No. 28 to "0" or "1." If the detection direction should be the same as the home return direction, specify the same value currently set in parameter No. 5 (Home return direction).

To set a direction opposite to the home return direction, specify the value different from the one currently set in parameter No. 5 (Home return direction).

(Example 1) Power was turned on when the slider was contacting the bottom mechanical end in a configuration where the actuator is installed vertically with the motor at the top.

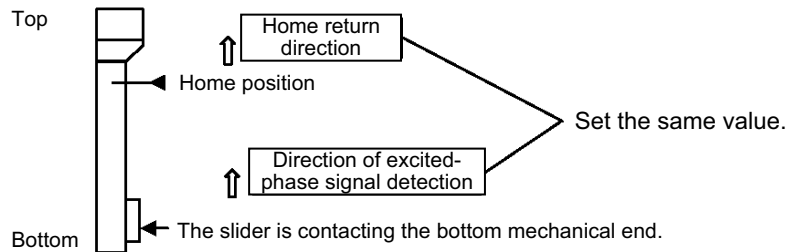

(Example 2) Power was turned on when the slider was contacting the bottom mechanical end in a configuration where the actuator is installed vertically with the motor at the bottom.

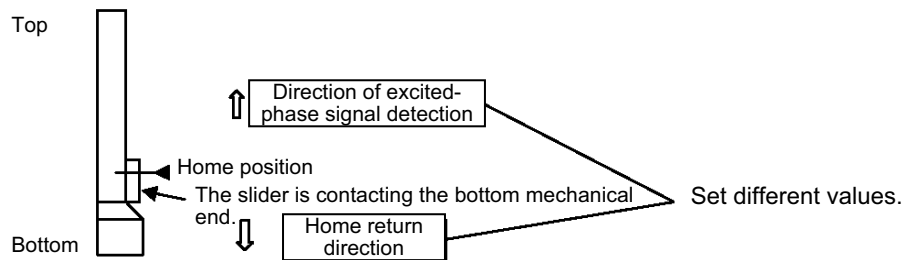

- Excited-phase signal detection time

When the servo is turned on for the first time after a power on, excited phase is detected. This parameter defines the time of this detection.

The parameter need not be changed in normal conditions, because a detection time appropriate for the standard specification of the actuator has been set at the factory.

Should an excitation detection error or abnormal operation occur when the servo is turned on for the first time after a power on, one remedial action that can be taken is to change the detection time set in parameter No. 29.

If you wish to change this parameter, contact IAI beforehand.

- Safety speed

This parameter defines the feed speed to be applied during manual operation.

The factory setting is "100 [mm/sec]."

To change this speed, set an optimal value in parameter No. 35.

Take note that the maximum speed is 250 mm/sec and that you should set a speed not exceeding this value.

● Automatic servo-off delay time

This parameter defines the delay time after the positioning is completed until the servo turns off automatically, when the “Standstill mode” field of the position table is set to 1, 2 or 3 (automatic servo-off control enabled) or parameter No. 53 (Default standstill mode) is set to 1, 2 or 3 (automatic servo-off control enabled).

Meaning of settings: 1: T becomes the value set in parameter No. 36.
 2: T becomes the value set in parameter No. 37.
 3: T becomes the value set in parameter No. 38.

The default setting is “0 [sec].”

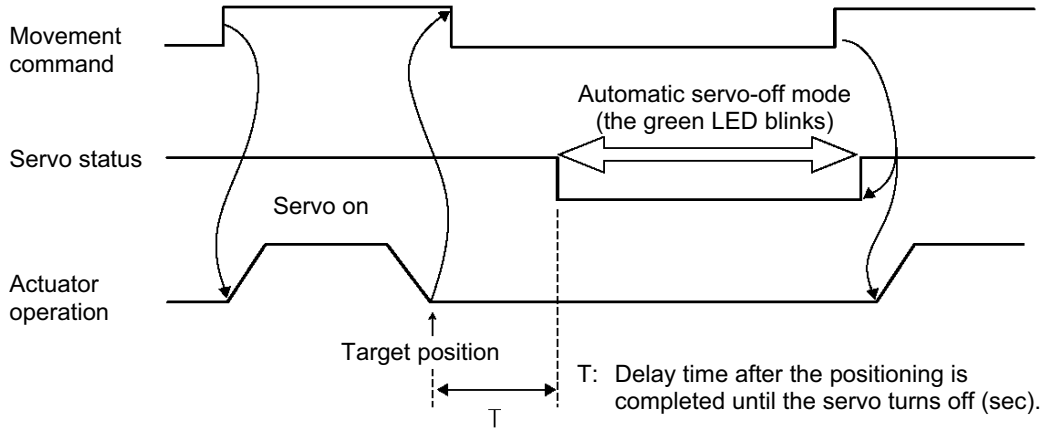

T: Delay time after the positioning is completed until the servo turns off (sec).

● Default standstill mode

This parameter defines the power-saving mode to be applied when the actuator stands by for a long time while the servo is on after the power has been turned on, or when the actuator stands by for a long time after completing the home return effected by the HOME input signal.

Define whether or not to enable power-saving, and which mode to use if power-saving is enabled, in parameter No. 53.

	Setting
All power-saving modes are disabled.	0
Automatic servo-off mode. The delay time is defined by parameter No. 36.	1
Automatic servo-off mode. The delay time is defined by parameter No. 37.	2
Automatic servo-off mode. The delay time is defined by parameter No. 38.	3
Full servo control mode	4

The factory setting is “0: [Disable].”

Automatic servo-off mode

After positioning is completed, the servo will turn off upon elapse of a specified time.
 (Since no holding current flows, the power consumption decreases.)

When the PLC issues the next movement command, the servo will turn on and the actuator will start moving.
 Refer to the above timing chart.

Full servo control mode

The pulse motor is servo-controlled to reduce the holding current.

Although the exact degree of current reduction varies depending on the actuator model, load condition, etc., the holding current decreases to approx. one-half to one-fourth.

Since the servo remains on, no position deviation occurs.

The actual holding current can be checked in the current monitor screen of the PC software.

● Push speed

This parameter defines the push speed to be applied after the actuator reaches the target position in push & hold operation.

Before the shipment, this speed has been set to a default value appropriate for the characteristics of the actuator. Set an appropriate speed in parameter No. 34 by considering the material and shape of the work part, and so on. Take note that the maximum speed is limited to 20 [mm/sec] even on high-speed types. Use the actuator at push speeds not exceeding this level.

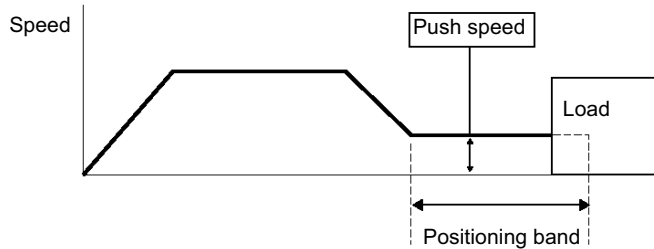

Caution: It is recommended that you set the push speed to 5 mm/sec or above to minimize the negative effect of push force variation.

● Push & hold stop judgment period

This parameter is used as a condition for determining that the work part was contacted and the push & hold operation has completed.

As for the specific method of judgment, the push & hold operation is deemed to have completed if the current-limiting value set in the position table has been retained for the time set in parameter No. 6.

Set an optimal time matching the current-limiting value, by considering the material and shape of the work part, and so on.

The minimum setting unit is "1 [msec]," while the maximum value is "9999 [msec]." The factory setting is "255 [msec]."

(Note) If the work part has shifted and the current has changed during the push & hold judgment, the judgment follows the timing chart shown below. This example assumes a judgment period of 255 msec.

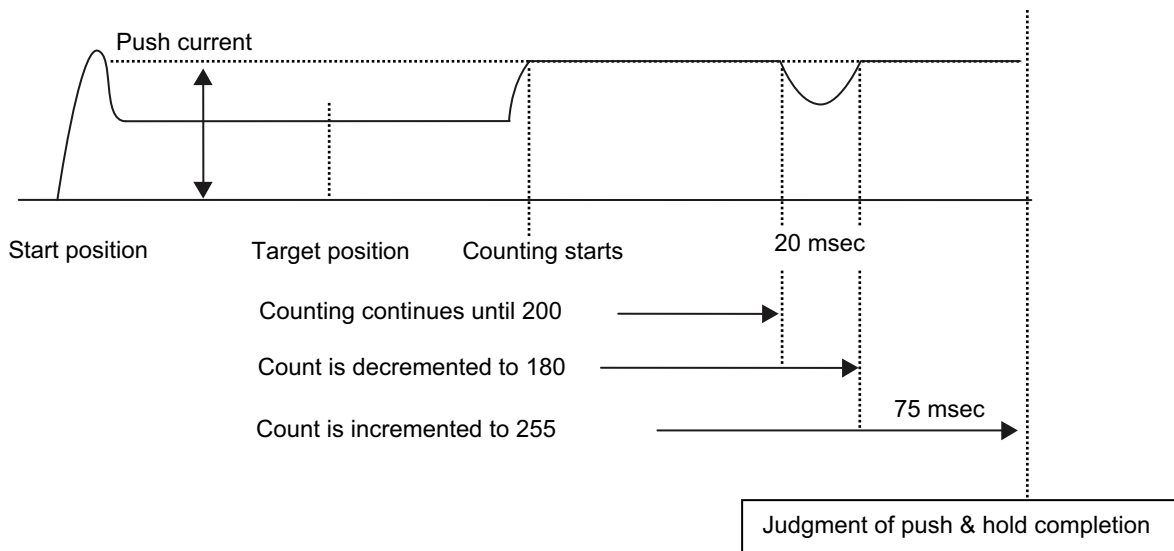

After reaching the push current, it is maintained for 200 msec. The current drops during the subsequent 20-msec period, and accordingly the count is decremented by 20. Therefore, when the operation is resumed the count will start from 180. Since the count will reach 255 after 75 msec at the push current, the controller will determine that the push & hold operation has completed.

In this example, the total judgment period is 295 msec.

8.2.3 Parameters Relating to the External Interface

- PIO pattern selection

Select a desired PIO operation pattern using parameter No. 25.

This parameter sets the basis of operation, so be sure to set it first.

Setting of parameter No. 25	Feature of the PIO pattern
0	8 points The basic pattern providing eight positioning points.
1	3 points (air cylinder) This pattern assumes that the actuator is used in place of an air cylinder. The number of positioning points is limited to three, but a direct command input and a position complete output are provided separately for each target position in line with the conventional practice of air cylinder control. This lets you control the actuator just like an air cylinder.
2	16 points (setting by zone boundary parameters) The number of positioning points is increased to 16. The boundaries defining the output range of the zone signal are set by parameters.
3	16 points (setting in zone fields in the position table) The number of positioning points is increased to 16. The boundaries defining the output range of the zone signal can be set differently for each position in the position table. Accordingly, this pattern is ideal for applications where the setup is changed from time to time.

The factory setting is "0: [8 points mode]."

- Movement command type

When the PIO pattern is set to "3 points," define the operation condition of the movement command input (ST0 to ST2) in parameter No. 27.

Description of the movement command input	Setting
Level mode: The actuator starts moving when the input signal turns ON. When the signal turns OFF during the movement, the actuator will decelerate to a stop and complete its operation, thereby returning to the initial mode.	0
Edge mode: The actuator starts moving when the rise edge of the input signal is detected. The actuator will not stop even when the signal turns OFF during the movement, until the target position is reached.	1

The factory setting is "0: [Level mode]."

[Level mode]

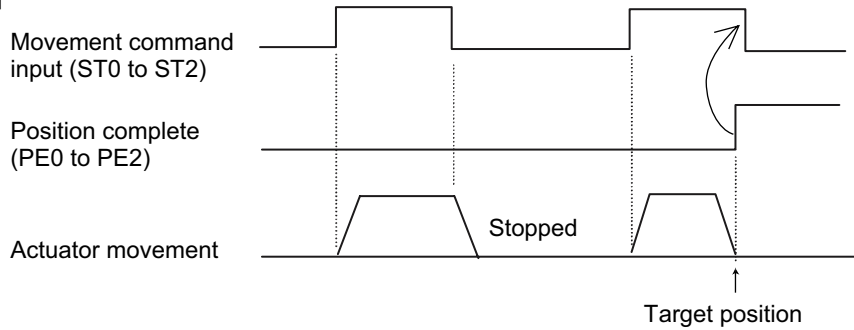

(Note) Turn OFF the movement command input after confirming that the target position has been reached.

[Edge mode]

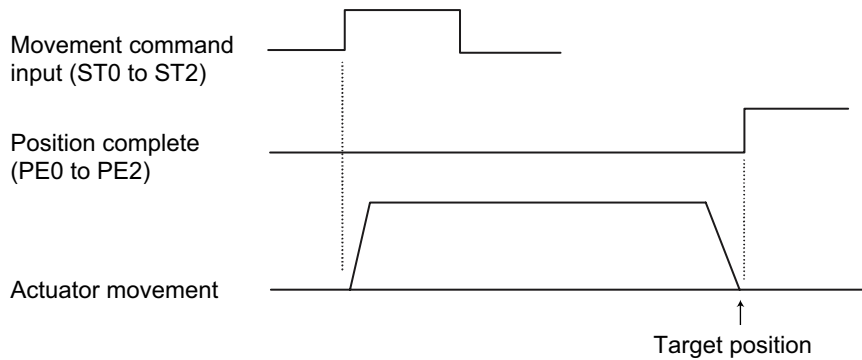

- Pause input disable selection

Parameter No. 15 defines whether the pause input signal is disabled or enabled.

	Setting
Enable (use)	0
Disable (do not use)	1

The factory setting is "0: [Enable]."

- Home-return input disable selection

Parameter No. 40 defines whether the home-return input signal is disabled or enabled.

	Setting
Enable (use)	0
Disable (do not use)	1

The factory setting is "0: [Enable]."

- Output mode of position complete signal

This parameter defines the status of position complete signal to be applied if the servo turns off or “position deviation” occurs while the actuator is standing still after completing positioning.

The following two conditions can be considered:

- [1] The position has deviated, due to external force and while the servo was on, beyond the value set in the “Positioning band” field of the position table.
- [2] The position has deviated, due to external force and while the servo was off, beyond the value set in the “Positioning band” field of the position table.

To support the above two conditions, how the “position complete status” is monitored can be specified flexibly in accordance with the characteristics of the system or sequence circuit on the PLC side.

Among others, it is recommended that this parameter be set to “1 [INP]” if position complete signals are to be used as auto-switches on an air cylinder in PIO pattern 1 (3 points).

The ON/OFF status of each position complete signal is controlled as follows in accordance with the setting of parameter No. 39.

Setting of parameter No. 39	[1] PIO pattern = 1 (3 points) Rear end complete (PE0), front end complete (PE1), or intermediate point complete (PE2) [2] PIO pattern = 0, 2, 3 (8 points/16 points) Position complete (PEND)
0 [PEND]	[1] When the servo is on The position complete signal remains ON even after the current position has exited the range set by the “Positioning band” field of the position table, with respect to the target position. [2] When the servo is off The position complete signal is OFF unconditionally regardless of the current position.
1 [INP]	Regardless of the servo on/off status, the position complete signal turns ON if the current position is within the range set by the “Positioning band” field of the position table, with respect to the target position, and turns OFF if the current position is outside this range. * In this mode, position complete signals are used as auto-switches on an air cylinder.

The factory setting is “0: [PEND].”

- SIO communication speed

This parameter is not used for this controller. It is applied to controllers of serial communication type.

If specified, this parameter sets the communication speed to be applied when the actuator is controlled via serial communication by means of the PLC’s communication module.

Set an appropriate value in parameter No. 16 in accordance with the specification of the communication module. You can select “9600,” “19200,” “38400,” “115200” or “230400” bps.

The factory setting is “38400 [bps].”

- Minimum delay for slave transmitter activation

This parameter is not used for this controller. It is applied to controllers of serial communication type.

If specified, this parameter sets the minimum delay time after the controller has received a command until the transmitter is activated, when serial communication is performed by means of the PLC’s communication module.

The factory setting is “5 [msec].” However, if the specification of the communication module is 5 msec or above, set the necessary time in parameter No. 17.

- Silent interval multiplication factor

This parameter is not used for this controller. It is applied to controllers of RS485 serial communication type. If specified, this parameter defines the multiplication factor to be applied to the silent interval time for delimiter judgment in the RTU mode.

The default setting is the communication time corresponding to 3.5 characters in accordance with the Modbus specification.

This setting need not be changed for normal operations performed with a PC or teaching pendant.

If the scan time of the PLC is not optimal and the character transmission interval exceeds the silent interval, the silent interval time can be extended using parameter No. 45.

The minimum setting unit is "1 [time]," while the input range is "0 to 10." If "0" is set, no multiplication factor is applied.

8.2.4 Servo Gain Adjustment

Before the shipment, the servo has been adjusted in accordance with the standard specification of the actuator. Accordingly, the servo settings need not be changed in normal conditions.

Nonetheless, the parameters relating to servo adjustment are made accessible by the customer so that speedy actions can be taken in situations where vibration or noise occurs due to the affixing method of the actuator, load condition, or the like.

In particular, custom types (having a longer ball screw lead or stroke than standard types) are more vulnerable to vibration and noise due to external conditions.

In such a case, the following parameter settings must be changed. Contact IAI beforehand.

- Servo gain number

Parameter No.	Unit	Input range	Default
7	5 rad/sec	0 ~ 31	6

This parameter determines the response when a position control loop is used.

Increasing the set value improves the tracking performance with respect to the position command.

However, increasing the value excessively increases the chances of overshoot.

If the value is small, the tracking performance with respect to the position command drops and positioning takes a longer time.

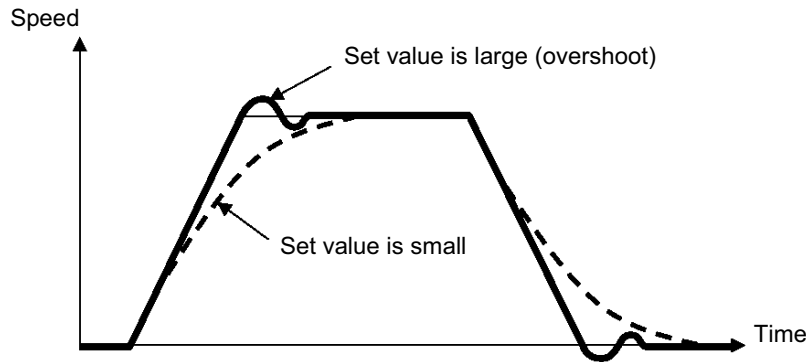

- Speed loop proportional gain

Parameter No.	Unit	Input range	Default
31	---	1 ~ 27661	Set individually in accordance with the actuator characteristics.

This parameter determines the response when a speed control loop is used.

Increasing the set value improves the tracking performance with respect to the speed command (i.e., servo rigidity increases).

The greater the load inertia, the larger this value should be.

However, increasing the value excessively makes the actuator more vulnerable to overshooting or shaking, leading to mechanical vibration.

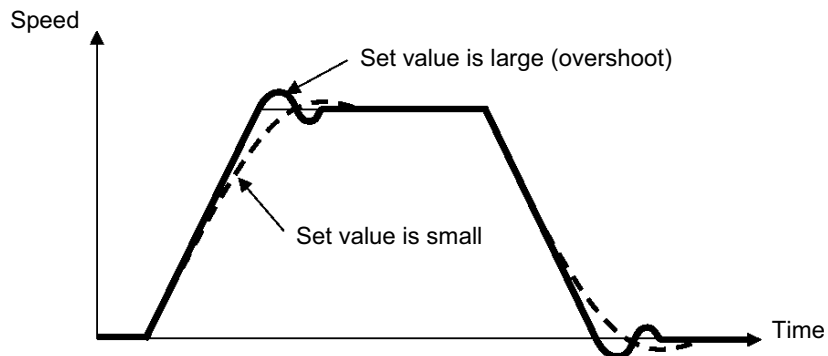

- Speed loop integral gain

Parameter No.	Unit	Input range	Default
32	---	1 ~ 217270	Set individually in accordance with the actuator characteristics.

This parameter is used to determine the response of the speed control loop. Reducing the set value lowers the response to speed commands, meaning that the reactive force that generates in response to load change becomes smaller. A smaller set value also results in poorer compliance with position commands, causing the positioning time to become longer. If the set value is excessive, on the other hand, the actuator may overshoot or oscillate, rendering the mechanical parts more prone to vibration.

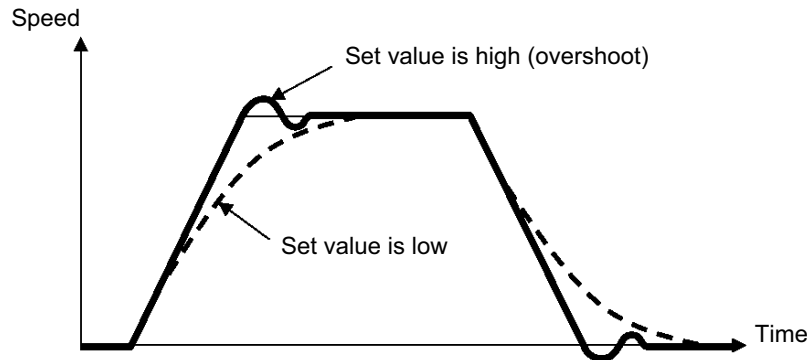

- Torque filter time constant

Parameter No.	Unit	Input range	Default
33	---	1 ~ 2500	Set individually in accordance with the actuator characteristics.

This parameter determines the filter time constant for torque commands. If the resonance frequency of the machine is smaller than the response frequency of the servo loop, the motor vibrates. This mechanical resonance can be suppressed by increasing the value set in this parameter. However, increasing the value excessively may reduce the stability of control.

9. Troubleshooting

9.1 Action to Be Taken upon Occurrence of Problem

Upon occurrence of a problem, take appropriate action according to the procedure below in order to ensure speedy recovery and prevent recurrence of the problem.

- a) Check the status indicator lamps.
Illuminating in green --- The servo is ON.
Illuminating in red --- An alarm is present or the motor drive power is cut off.
- b) Check for error in the host controller.
- c) Check the voltage of the main 24-VDC power supply.
- d) Check for alarm.
Confirm the details of error on the PC or teaching pendant.
- e) Check the cables for connection error, disconnection or pinching.
Before performing a continuity check, turn off the power (to prevent a runaway actuator) and disconnect the cables (to prevent accidental power connection due to a sneak current path).
- f) Check the I/O signals.
- g) Check the noise elimination measures (grounding, installation of surge killer, etc.).
- h) Review the events leading to the occurrence of problem, as well as the operating condition at the time of occurrence.
- i) Check the serial numbers of the actuator.
- j) Analyze the cause.
- k) Take action.

Please check items a) through k) before contacting IAI.

9.2 Alarm Level Classification

Alarms are classified into two levels according to the symptoms they represent.

Alarm level	LED color	*ALM signal	What happens when alarm generates	How to reset
Operation cancellation	Red	OFF	The actuator decelerates to a stop and then the servo turns OFF.	See below.
Cold start	Red	OFF	The actuator decelerates to a stop and then the servo turns OFF.	Reconnect the power or reset the software.

(Note) The *ALM output signal is a contact-b signal.
 When the power is on, this signal remains ON while the actuator is normal, and turns OFF if an alarm has occurred.
 When the power is cut off, the signal remains OFF. However, it cannot be used as a contact-b interlock signal.

9.2.1 How to Reset Alarms

■ PIO pattern = 8 points or 16 points

Cut off the motor drive power, and then input a start signal (CSTR) for at least 6 msec.
 After the *ALM signal has turned ON, confirm that it is ON, turn the CSTR signal OFF, and then restore the motor drive power.

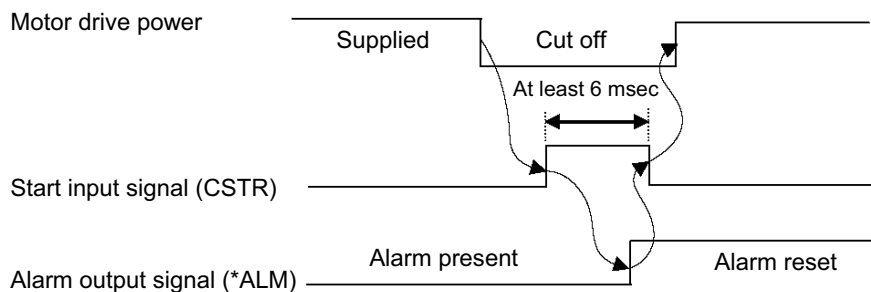

■ PIO pattern = 3 points

Input an alarm reset signal (RES) for at least 6 msec.
 After the *ALM signal has turned ON, confirm that it is ON and then turn the RES signal OFF.

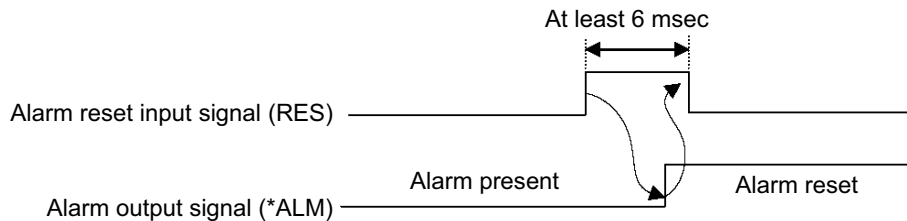

Caution: Before resetting an alarm, always identify and remove the cause of the alarm. If the cause cannot be removed or the alarm still persists after removing the cause, contact IAI. If the same error occurs again after resetting the alarm, the problem that caused the alarm in the first place is still present.

9.3 Alarm Description and Cause/Action

(1) Operation-cancellation level alarms

Code	Error name	Cause/Action
A1	Parameter data error	<p>Cause: The parameter data does not meet the specified input range. (Example) This alarm generates when a pair of values clearly has an inappropriate magnitude relationship, such as when the soft limit + setting is 200.3 mm, while the soft limit – setting is 300 mm.</p> <p>Action: Change the settings to appropriate values.</p>
A2	Position data error	<p>Cause: [1] A movement command was input when a target position was not yet set in the “Position” field. [2] The target position in the “Position” field is outside the soft limit range.</p> <p>Action: [1] Set a target position first. [2] Change the target position to a value inside the soft limit range.</p>
BE	Home return timeout	<p>Cause: Home return does not complete within the period set in the applicable system parameter after the start of home return operation. (This alarm should not occur in normal operations.)</p> <p>Action: Inappropriate controller/actuator combination is a possible cause. Contact IAI.</p>
C0	Excessive actual speed	<p>Cause: This alarm indicates that the motor speed exceeded the maximum speed set in the applicable system parameter. This alarm will not generate in normal operation, but may occur in the following conditions: [1] Large actuator slide resistance in certain area, or [2] Instantaneous increase in load due to application of external force, which may cause the load to decrease and actuator to move rapidly before a servo error is detected.</p> <p>Action: Check for abnormality in the assembly condition of mechanical parts. If the actuator is suspected to be the cause, please contact IAI.</p>
C1	Servo error	<p>This alarm indicates that after receiving a movement command the motor is unable to operate for two seconds or more before reaching the target position.</p> <p>Cause: [1] Loose or disconnected connector of the motor extension cable [2] Brake cannot be released on a controller equipped with brake. [3] Large load due to application of external force [4] Large slide resistance of the actuator itself</p> <p>Action: [1] Check the wiring condition of the motor extension cable. [2] Check the wiring condition of the brake cable, and also turn on/off the brake release switch to check if a “click” sound is heard. [3] Check for abnormality in the assembly condition of mechanical parts. [4] If the load is normal, turn off the power and move the actuator by hand to check the slide resistance. If the actuator is suspected to be the cause, please contact IAI.</p>

Code	Error name	Cause/Action
C9	Excessive motor supply voltage	This alarm indicates that the motor supply voltage is excessive (24 V + 20%: 28.8 V or more). Cause: [1] High voltage of the 24-V input power supply [2] Faulty internal part of the controller Action: Check the voltage of the input power supply. If the voltage is normal, please contact IAI.
CA	Overheating	The temperature around the power transistor in the controller is too high (95°C or above). Cause: [1] High ambient temperature [2] Defective internal part of the controller Action: [1] Lower the ambient temperature of the controller. If the action in [1] does not apply, contact IAI.
CC	Abnormal control supply voltage	This alarm indicates that the voltage of the 24-V input power supply is excessive (24 V + 20%: 28.8 V or more). Cause: [1] High voltage of the 24-V input power supply [2] Defective internal part of the controller Action: Check the voltage of the input power supply. If the voltage is normal, please contact IAI.
CE	Drop in control supply voltage	This alarm indicates that the voltage of the 24-V input power supply has dropped (24 V – 20%: 19.2 V or less). Cause: [1] Low voltage of the 24-V input power supply [2] Defective internal part of the controller Action: Check the voltage of the input power supply. If the voltage is normal, please contact IAI.

(2) Cold-start level alarms

Code	Error name	Cause/Action
B8	Excitation detection error	<p>This controller detects excited phase when the servo is turned on for the first time after a power on. This alarm indicates that the specified encoder signal level cannot be detected after the specified period of excitation.</p> <p>Cause:</p> <ul style="list-style-type: none"> [1] Loose or disconnected connector of the motor extension cable [2] The brake cannot be released (if the actuator is equipped with a brake). [3] A large load is applied due to an external force. [4] The power was turned on when the actuator was contacting a mechanical end. [5] The slide resistance of the actuator itself is large. <p>Action:</p> <ul style="list-style-type: none"> [1] Check the wiring condition of the motor extension cable. [2] Check the wiring condition of the brake cable, and also turn on/off the brake release switch to check if a "click" sound is heard. [3] Check for abnormality in the assembly condition of mechanical parts. Increasing the value of parameter No. 29 (Excited-phase signal detection time) may be effective. If you wish to change the parameter setting, contact IAI beforehand. [4] Move the actuator away from the mechanical end, and then turn on the power again. Alternatively, change the value of parameter No. 28 (Default direction of excited-phase signal detection). [5] If the load is normal, turn off the power and move the actuator by hand to check the slide resistance. If the actuator is suspected to be faulty, please contact IAI.
D8	Deviation overflow	<p>The position deviation counter has overflowed.</p> <p>Cause:</p> <ul style="list-style-type: none"> [1] The speed dropped due to external force, etc., while the actuator was moving. [2] Unstable excitation detection operation after the power has been turned on <p>Action:</p> <ul style="list-style-type: none"> [1] Check the load condition, such as if the work part is contacting any object around it or the brake is released, and remove the identified cause. [2] An overload condition is suspected, so review the loading mass. After appropriate adjustment has been made, reconnect the power and perform home return.
DC	Out-of-range error in push & hold operation	<p>This alarm occurs when the actuator was pushed back to the target position after completion of push & hold operation, due to a strong push-back force of the work part. Review the overall settings of the system.</p>

Code	Error name	Cause/Action
F5	Verification error of data written to nonvolatile memory	When data was written to the nonvolatile memory, the written data is read and compared (verified) against the original data. This alarm indicates that the read data does not mach the original data written. Cause: [1] Faulty nonvolatile memory [2] The memory has been rewritten more than 100,000 times. (As a rough guideline, the nominal service life of the nonvolatile memory is 100,000 rewrites.) Action: If the alarm persists after reconnecting the power, contact IAI.
F6	Timeout writing to nonvolatile memory	This alarm indicates that a response was not received within the specified time after writing the nonvolatile memory. Cause: [1] Faulty nonvolatile memory [2] The memory has been rewritten more than 100,000 times. (As a rough guideline, the nominal service life of the nonvolatile memory is 100,000 rewrites.) Action: If the alarm persists after reconnecting the power, contact IAI.
F8	Damaged nonvolatile memory	Abnormal data was detected in the nonvolatile memory check upon start. Cause: [1] Faulty nonvolatile memory [2] The memory has been rewritten more than 100,000 times. (As a rough guideline, the nominal service life of the nonvolatile memory is 100,000 rewrites.) Action: If the alarm persists after reconnecting the power, contact IAI.
FA	CPU error	The CPU is not operating normally. Cause: [1] Faulty CPU [2] Malfunction due to noise Action: If the alarm persists after reconnecting the power, contact IAI.

9.4 Messages Displayed during Operation Using the Teaching Pendant

This section explains the warning messages that may be displayed during operation using the teaching pendant.

Code	Error name	Cause/Action
112	Invalid data	An inappropriate value was entered in a parameter. (Example) 9601 was entered as the serial communication speed by mistake. Enter an appropriate value again.
113 114	Value too small Value too large	The entered value is smaller than the setting range. The entered value is larger than the setting range. Refer to the actuator specifications or parameter table and enter an appropriate value again.
115	Home return non-completion	The current position was written when home return was not yet completed. Execute home return again.
117	No movement data	Target position is not set under the selected position number. Enter the target position first.
11E	Paired data mismatch	The values indicating the magnitude relationship of a pair of data are inappropriate. (Example) The same value was entered in both the parameters for + and – soft limits. Enter appropriate values again.
11F	Absolute position too small	The minimum movement toward the target position is determined by the lead length of the drive system and resolution of the encoder. This message indicates that the entered target value is smaller than the minimum movement. (Example) If the lead length is 16 mm, the encoder's resolution is 800 pulses and accordingly the minimum movement becomes $16 \div 800 = 0.02$ mm/pulse. In this case, this message will be displayed if 0.01 mm is entered as the target position.
121	Push & hold search end over	The final position in push & hold operation exceeds the soft limit. This has no negative effect if the actuator contacts the work part. If the actuator misses the work part, however, the soft limit will be reached and thus this message is displayed as a warning. Change either the target position or positioning band.
122	Multiple axes connected at assignment	Address was assigned when multiple axes were connected. Assign each address only when one axis is connected.
180 181 182 183	Address change OK Controller initialization OK Home change all clear I/O function changed	These messages are displayed to confirm operation. (They don't indicate an operation error or other abnormality.)
202	Emergency stop	An emergency stop has been actuated.

Code	Error name	Cause/Action
20C	CSTR-ON during operation	This message indicates that the start signal (CSTR) was turned ON by the PLC while the actuator was moving, and that duplicate movement commands occurred as a result.
20D	STP-OFF during operation	This message indicates that the pause signal (*STP) was turned OFF by the PLC while the actuator was moving, and that the movement was disabled as a result.
20E	Soft limit over	This message indicates that a soft limit was reached.
210	HOME-ON during operation	This message indicates that the home return signal (HOME) was turned ON by the PLC while the actuator was moving, and that duplicate movement commands occurred as a result.
221	Write prohibited in monitor mode	This message indicates that an attempt was made to write data to a position table or parameter in the monitor mode.
223	Operation prohibited in monitor mode	This message indicates that an attempt was made to move the actuator in the monitor mode.
301 302 304 305 306 308 30A 30B	Overrun error (M) Flaming error (M) SCIR-QUE OV (M) SCIS-QUE OV (M) R-BF OV Response timeout (M) Packet R-QUE OV Packet S-QUE OV	<p>These messages indicate an error in the serial communication with the controller.</p> <p>Cause: [1] Garbage data due to the effect of noise [2] Duplicate slave numbers when multiple controllers are controlled by serial communication</p> <p>Action: [1] Adjust the wiring in a manner eliminating the effect of noise and review the installation of equipment, etc. [2] Change the slave numbers to avoid duplication.</p> <p>If the message is still displayed after taking the above actions, please contact IAI.</p>
307	Memory command refused	This message indicates that the command was refused in the serial communication with the controller.
309	Write address error	<p>This message indicates that an indeterminate WRITE address error occurred in the serial communication with the controller.</p> <p>These conditions do not occur in normal operation. Should they occur, record the entire error list before cutting off the power for use in the cause investigation.</p> <p>Also contact IAI.</p>
30C	No connected axis	<p>This message indicates that no controller address is recognized.</p> <p>Cause: [1] The controller is not operating properly. [2] Only the supplied communication cable (SGA/SGB) is disconnected. [3] If a SIO converter is used, 24 V is supplied to the converter but the link cable is not connected. [4] Duplicate slave numbers in a configuration where multiple controllers are linked.</p> <p>Action: [1] Check if the RDY LED on the controller is lit. If this LED is unlit, the controller is faulty. [2] If a spare teaching pendant is available, replace the current pendant with the spare unit, or with a PC, and see if the message disappears. [3] Connect the link cable between the converter and controller first, and then supply the power. [4] Eliminate duplication among slave numbers.</p> <p>If the message is still displayed after taking the above actions, please contact IAI.</p>

9.5 Specific Problems

- I/O signals cannot be exchanged with the PLC.
Cause: [1] The 24-V I/O power supply is connected in reverse.
(This will not affect the input circuits, but the output circuits may be damaged.)
[2] If the problem is with an output circuit, a circuit component may have been damaged due to a large load that caused the current flowing into the circuit to exceed the maximum level.
[3] Contact failure in the connector or relay terminal block on the PLC end.
Action: Check the connection condition of the power supply and connector, as well as the load on the output side.
If the cause is identified as [1] or [2], the controller board must be replaced. Please contact IAI.

- The LED lamp does not illuminate after the power is input.
Cause: [1] Reverse connection of the 24-V power supply
[2] Faulty controller board
If the power supply is connected properly, probably the controller board is faulty. Please contact IAI.
(Note) If the 24-V power supply is connected in reverse, the controller may not fail immediately but its service life will likely be shortened.

- The LED illuminates in red when the power is turned on.
(An alarm is present or the motor drive power is cut off.)
Check on the I/O monitor screen of the PC or teaching pendant if the alarm signal (*ALM) is output.
If the alarm signal is output, check the description of the error and remove the cause.
If alarm code 41 (motor voltage drop) is displayed, it means the motor drive power is cut off. Check the following items:
[1] Is the emergency-stop switch on the operation panel pressed? Also confirm that the necessary interlocks are released.
[2] Is the emergency-stop switch on the teaching pendant pressed?
[3] If a SIO converter is used, is the PORT switch turned ON when a teaching pendant is not connected?

- Home return ends in the middle in a vertical application.
Cause: [1] The load exceeds the rating.
[2] The ball screw is receiving torsional stress due to the affixing method of the actuator, tightening of bolts only on one side, etc.
[3] The slide resistance of the actuator itself is large.
Action: [1] Increase the value set in user parameter No. 13 (Current-limiting value during home return).
Increasing this value will cause the home return torque to increase, so do not increase the parameter setting above 75%.
[2] Loosen the fixing bolts and check if the slider moves smoothly.
If the slider moves smoothly, review the affixing method and bolt tightening condition.
[3] If the slide resistance of the actuator itself is large, please contact IAI.

- Noise occurs during downward movements in a vertical application.
Cause: The load exceeds the rating.
Action: [1] Decrease the speed.
[2] Decrease the value set in the user parameter No. 7 (Servo gain number). Do not decrease the parameter setting below “3.”

- Vibration occurs when the actuator is stopped.
Cause: The slider is receiving an external force.
Action: If the external force cannot be removed, increase the value set in user parameter No. 12 (Current-limiting value at standstill during positioning).
Increasing this value will cause the holding torque at standstill to increase, so do not increase the parameter setting above 70%.

- The actuator overshoots when decelerated to a stop.
Cause: The load inertia is high in view of the balance of load and deceleration.
Action: Decrease the deceleration setting.

- The home and target positions sometimes shift on the rod-type actuator.
Cause: The added rotational moment to the rod increased the non-rotational accuracy.
Action: The actuator may have to be replaced in some cases. Please contact IAI.

- The speed is slow during push & hold operation.
Cause: The current-limiting value is lower than what is required in view of the loading mass and slide resistance.
Action: Increase the current-limiting value for push & hold operation.

- The actuator moves only a half, or as much as twice, the specified travel.
Cause: Pre-shipment setting error at IAI is suspected.
Action: Contact IAI.

- The actuator operates abnormally when the servo is turned on following the power on.
Cause: The excited phase is not detected correctly when the servo is turned on because of one of the following conditions at the time of power on:
[1] The slider or rod is contacting the mechanical end.
[2] An excessive external force is exerted to the load.
Action: [1] Check if the slider or rod is contacting the mechanical end. If it is, move the slider/rod away from the mechanical end. If the actuator is equipped with a brake, move the slider/rod after releasing the brake by turning on the brake release switch. At this time, pay attention to prevent the load from falling due to its dead weight and protect your hand, robot, and the work part from injuries/damages.
If the actuator cannot be moved by hand, you can check the direction of excited-phase signal detection and change the direction, if necessary. If you wish to attempt this course of action, please contact IAI.
For details, refer to 8.2.2, “Parameters Relating to the Actuator Operating Characteristics.”
[2] Check if the load is in contact with an object in the surroundings. If so, move the load away from the obstruction to provide a minimum clearance of 1 mm.
If neither of causes [1] and [2] is present, please contact IAI.

- The LED (green) blinks.
The automatic servo-off mode is currently active. (This is not an error or failure.)

10. Maintenance and Inspection

10.1 Inspection Items and Schedule

Perform maintenance and inspection per the schedule specified below.

This schedule assumes eight hours of operation a day. Shorten the inspection intervals if the utilization is higher, such as when the actuator is operated continuously day and night.

	Visual inspection of appearance	Greasing	Model
Start-up inspection	○		
After 1 month of operation	○		
After 3 months of operation	○	○ (Rod slide surface)	Rod type *1
Every 3 months thereafter	○	○ (Rod slide surface)	Rod type *1
After 3 years of operation or 5,000 km of moving distance	○	○ (Guide/ball screw)	Slider type *2
Every 1 year thereafter	○	○ (Guide/ball screw)	Slider type *2

*1 With a rod-type actuator, grease the rod slide surface if the surface is found dry at the start-up inspection or every three months.

*2 With a slider-type actuator, grease the guide and ball screw as necessary by considering the use environment, condition, etc.

10.2 Visual Inspection of Appearance

Check the following items in the visual inspection:

Actuator	Loose actuator-mounting bolts, etc.
Cables	Damage, connector coupling
Overall	Noise, vibration

10.3 Cleaning

- Clean the exterior as necessary.
- Wipe off dirt using a soft cloth, etc.
- Do not blow compressed air at high speed. Doing so may cause dust to enter the actuator through gaps.
- Do not use petroleum solvent, since it will damage the resin and coated surfaces.
- To remove significant soiling, wipe the area gently using a soft cloth, etc., moistened with neutral detergent.

10.4 Internal Check (Slider Type)

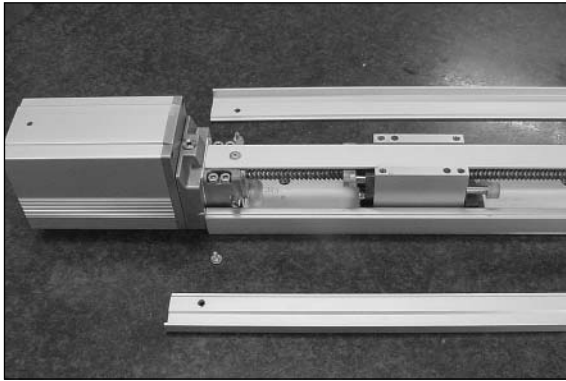
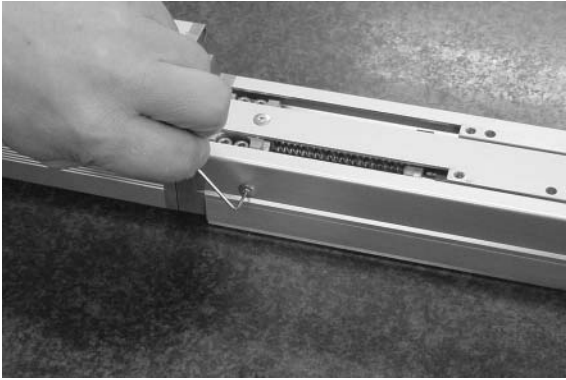

- [1] With the SA6C and SA7C, the screw cover and side covers can be removed using a hex wrench with 1.5 mm width across flats.
- The front and rear brackets are supporting the ball screw, so do not disassemble these brackets.
 - Precision instrument is assembled into the motor cover, so do not disassemble the motor cover.

- [2] Visually check the internal condition. Check for intrusion of dust and other foreign object, and also check the lubrication condition. Even when the grease is brown, the sliding surface is lubricated properly if the surface looks wet and glowing.

Warning: The encoder phase is adjusted precisely to enable detection of rotation angle and home signal. Never touch the encoder, since it may cause a breakdown.

- [3] If the grease is contaminated with dust and not glowing, or if the grease has been consumed over a long period of use, apply grease after cleaning the respective parts.
- [4] When the inspection/maintenance is complete, install the side covers, stainless sheet and slider cover by reversing the procedure in step [1] above. The tightening torque should be around the level applicable for cross-recessed screws.

10.5 Internal Cleaning (Slider Type)

- Wipe off dirt using a soft cloth, etc.
- Do not blow compressed air at high speed. Doing so may cause dust to enter the actuator through gaps.
- Do not use petroleum solvent, neutral detergent or alcohol.

 **Caution:** Do not use cleaning oil, molybdenum grease or rustproof lubricant. If a large amount of foreign object is contained in the grease, wipe off the dirty grease before applying new grease.

10.6 Greasing the Guide (Slider Type)

(1) Applicable grease

IAI uses lithium grease No. 2.

The following grease is applied to the guides prior to shipment:

Idemitsu Kosan	Daphne Eponex Grease No. 2
----------------	----------------------------

Equivalent grease products are available from other companies. For details, contact each manufacturer and ask for a product equivalent to the aforementioned brand. Equivalence of the following products has been confirmed:

Showa Shell Sekiyu	Albania Grease S2
ExxonMobil	UNIREX N2

 **Caution:** In case the grease got into your eye, immediately go to see the doctor to get an appropriate care. After finishing the grease supply work, wash your hands carefully with water and soap to rinse the grease OFF.

(2) Greasing method

Grease the guide by following the procedure below:

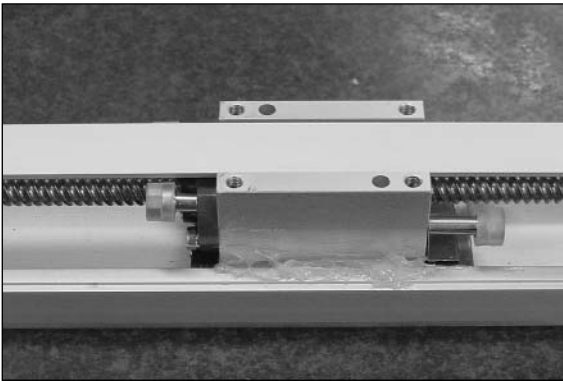

- [1] Apply grease between the slider and base, as shown to the left.
Apply grease on the opposite side in the same manner.

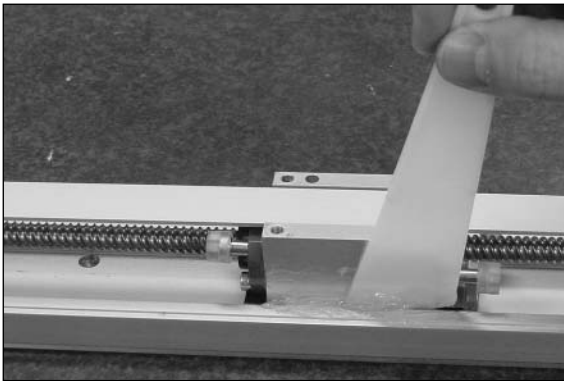

- [2] Spread the grease evenly between the slider and base using a spatula, as shown to the left.
Spread the grease evenly on the opposite side in the same manner.

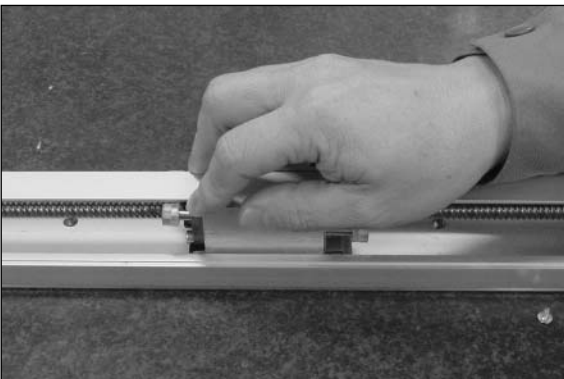

- [3] Move the slider back and forth several times by hand.
- [4] Repeat steps [1], [2] and [3].
- [5] Use a waste cloth, etc., to wipe off excess grease from the slider.

 **Caution:** In case the grease got into your eye, immediately go to see the doctor to get an appropriate care.
After finishing the grease supply work, wash your hands carefully with water and soap to rinse the grease OFF.

10.7 Greasing the Ball Screw (Slider Type)

(1) Applicable grease

The following special grease is applied to the ball screw prior to shipment:

Kyodo Yushi	Multemp LRL3
-------------	--------------

This grease generates less heat and has other excellent properties suitable for ball screws. For equivalent grease products, refer to the brands specified for the guide (lithium grease).

! Note: Never use fluorine grease. If fluorine grease is mixed with lithium grease, the grease function will drop and it causes damage to the mechanism.

(2) Greasing method

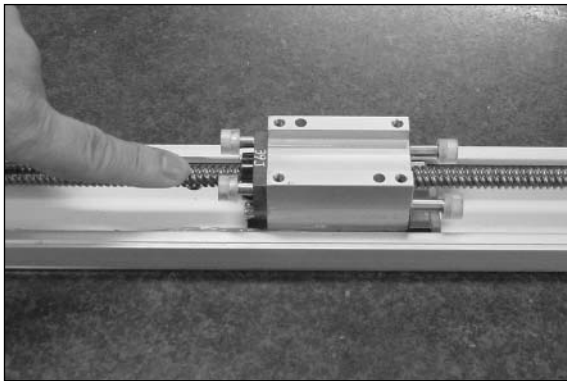

After cleaning the ball screw, apply grease and stroke the slider to let the grease spread evenly. As the final step, wipe off excess grease from the ball screw.

This is because excessive grease will cause the agitation resistance to increase and allow the ball screw to generate heat easily. Wiping off excess grease will also prevent extra grease on the ball screw from flying off and staining the surrounding area as the screw turns.

* With the ERC2, the speed will vary depending on the load. Be careful not to grease the ball screw excessively.

! Caution: In case the grease got into your eye, immediately go to see the doctor to get an appropriate care. After finishing the grease supply work, wash your hands carefully with water and soap to rinse the grease OFF.

10.8 Greasing the Rod Slide Surface

(1) Applicable grease

The following grease is applied to the rod slide surface prior to shipment:

Kyodo Yushi	Multemp LRL3
-------------	--------------

Use lithium grease for maintenance.

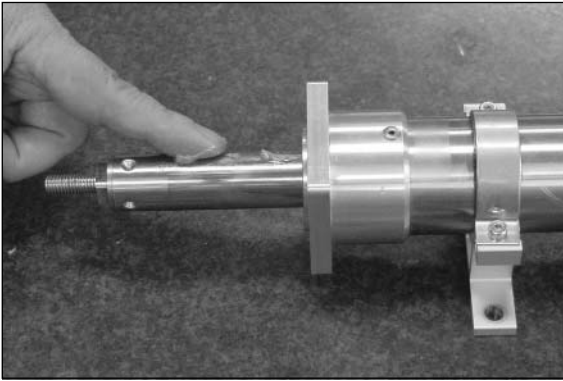

! Note: Never use fluorine grease. If fluorine grease is mixed with lithium grease, the grease function will drop and it causes damage to the mechanism.

! Caution: In case the grease got into your eye, immediately go to see the doctor to get an appropriate care. After finishing the grease supply work, wash your hands carefully with water and soap to rinse the grease OFF.

10.9 Motor Replacement Procedure

Before replacing the motor, save the latest parameter and position data.

Save the data by one of the following methods:

- Save the data to a file using the PC software.
- Prepare position/parameter tables and manually write the values.

When a new motor has been installed, enter the parameter/position data to the controller.

Follow the procedure below to replace the motor unit or coupling spacer:

- Removal

- [1] Remove the coupling bolt from the rear bracket using a wrench with 3 mm width across flats.
- [2] Hold the motor cover and pull backward to remove the motor unit. (Exercise caution to prevent pinching of parts.)

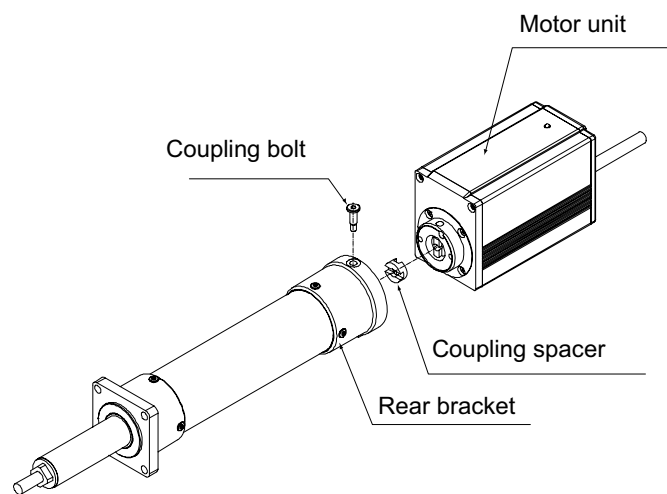
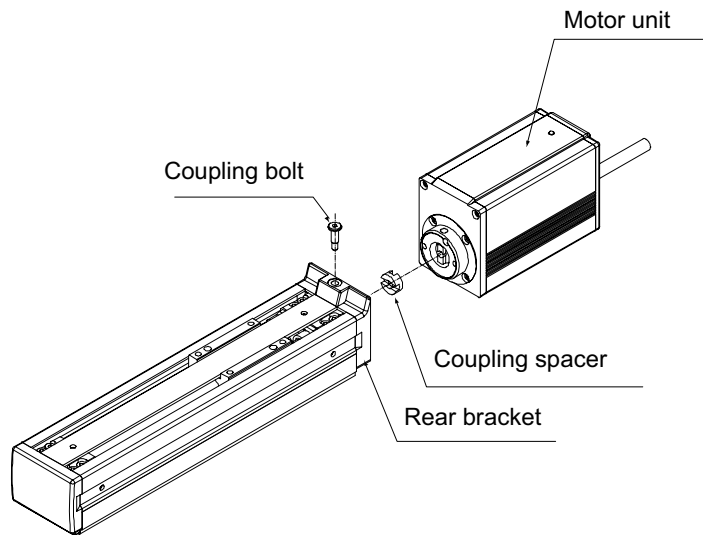

- Installation

- [1] Place the coupling spacer in the coupling hub.
- [2] Insert the motor unit into the rear bracket while paying attention to the phase of the coupling hub with respect to the coupling spacer. (When inserting the motor unit, exercise due caution to prevent pinching of parts.)
- [3] Insert the coupling bolt into the fitting hole in the motor unit from over the rear bracket, and tighten the bolt using a wrench with 3 mm width across flats.

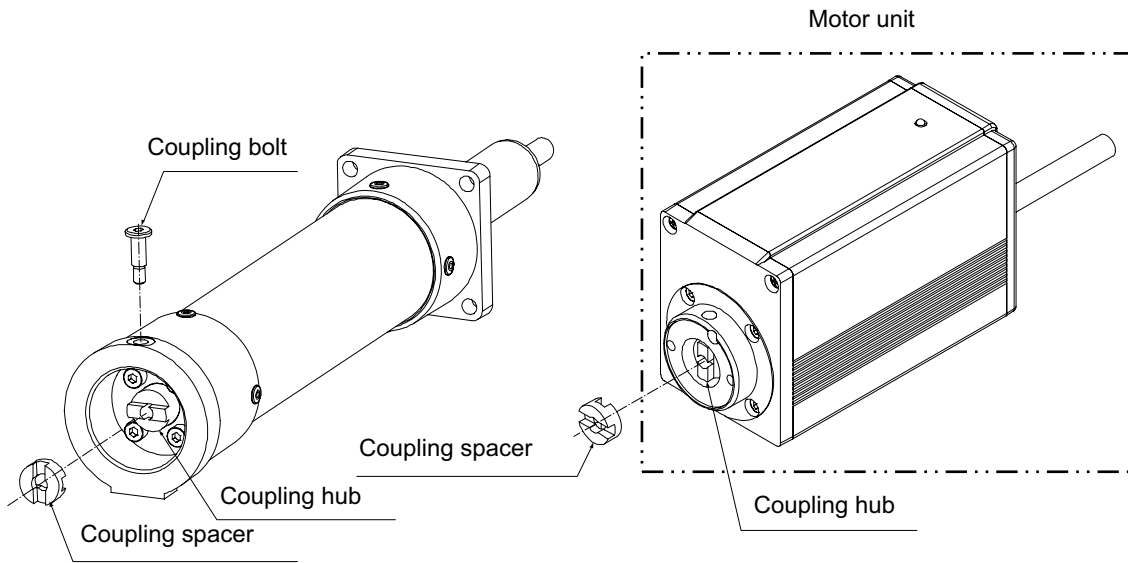

11. Appendix

11.1 External Dimensions

11.1.1 ERC2-SA6C

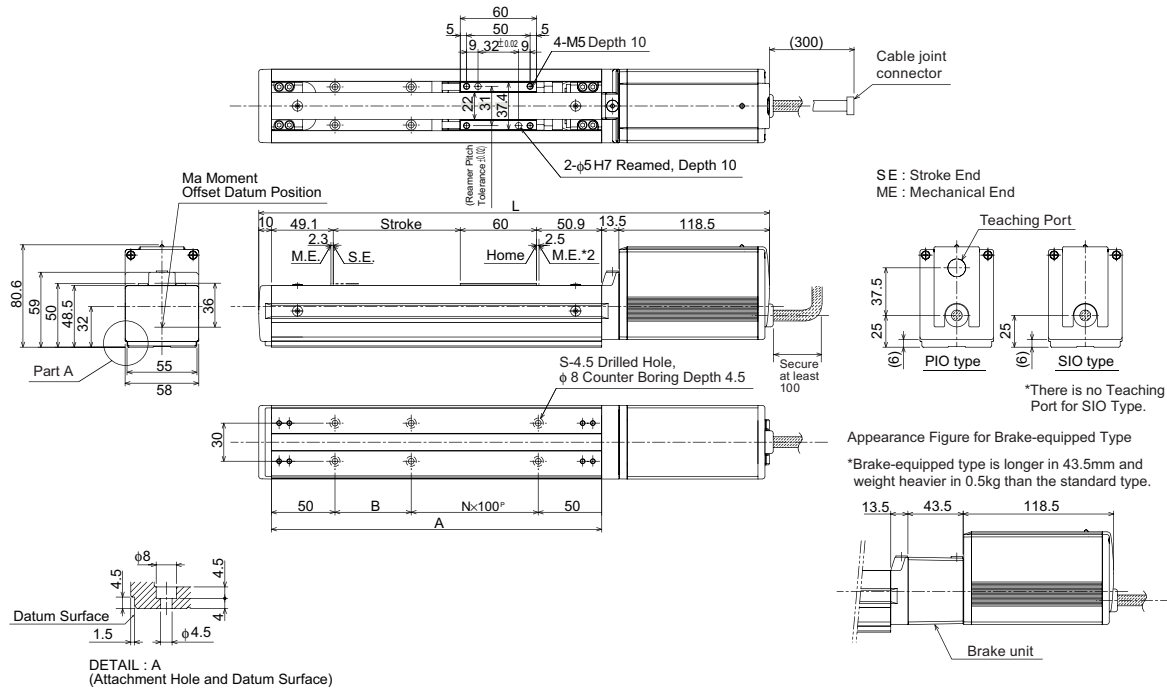

Stroke	50	100	150	200	250	300	350	400	450	500	550	600
L	352	402	452	502	552	602	652	702	752	802	852	902
A	210	260	310	360	410	460	510	560	610	660	710	760
B	10	60	10	60	10	60	10	60	10	60	10	60
N	1	1	2	2	3	3	4	4	5	5	6	6
S	6	6	8	8	10	10	12	12	14	14	16	16
Weight [kg]	1.9	2.0	2.1	2.3	2.4	2.6	2.7	2.8	3.0	3.1	3.3	3.4

11.1.2 ERC2-SA7C

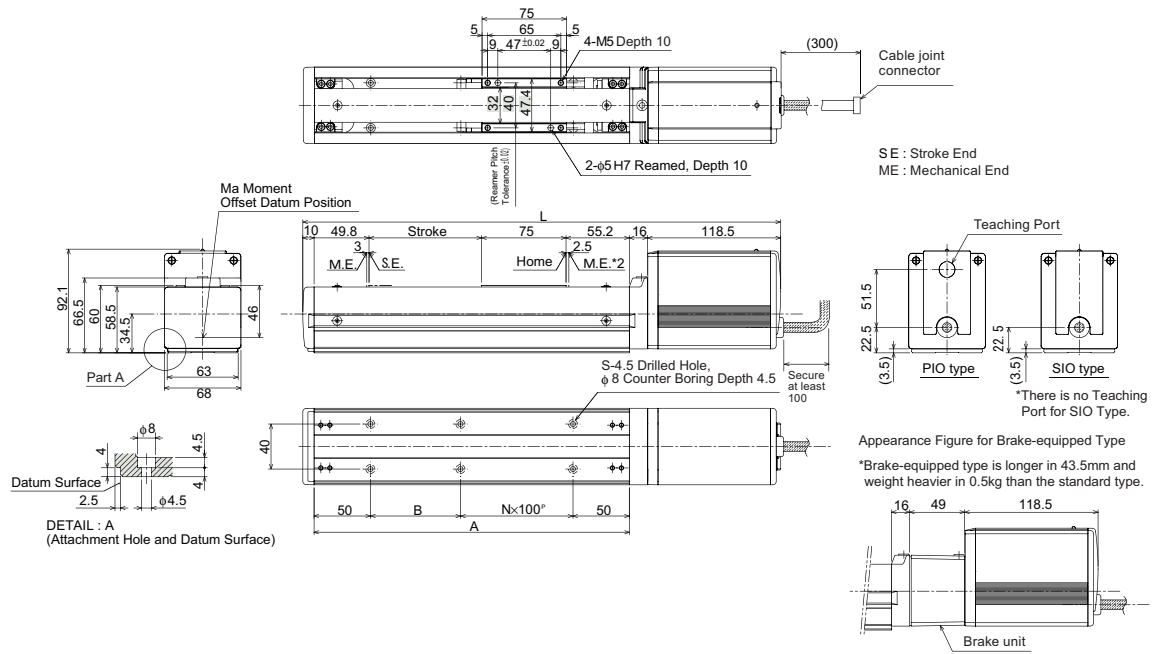

Stroke	50	100	150	200	250	300	350	400	450	500	550	600
L	374.5	424.5	474.5	524.5	574.5	624.5	674.5	724.5	774.5	824.5	874.5	924.5
A	230	280	330	380	430	480	530	580	630	680	730	780
B	30	80	30	80	30	80	30	80	30	80	30	80
N	1	1	2	2	3	3	4	4	5	5	6	6
S	6	6	8	8	10	10	12	12	14	14	16	16
Weight [kg]	3.1	3.2	3.4	3.6	3.7	3.9	4.0	4.2	4.3	4.5	4.6	4.8

11.1.3 ERC2-RA6C

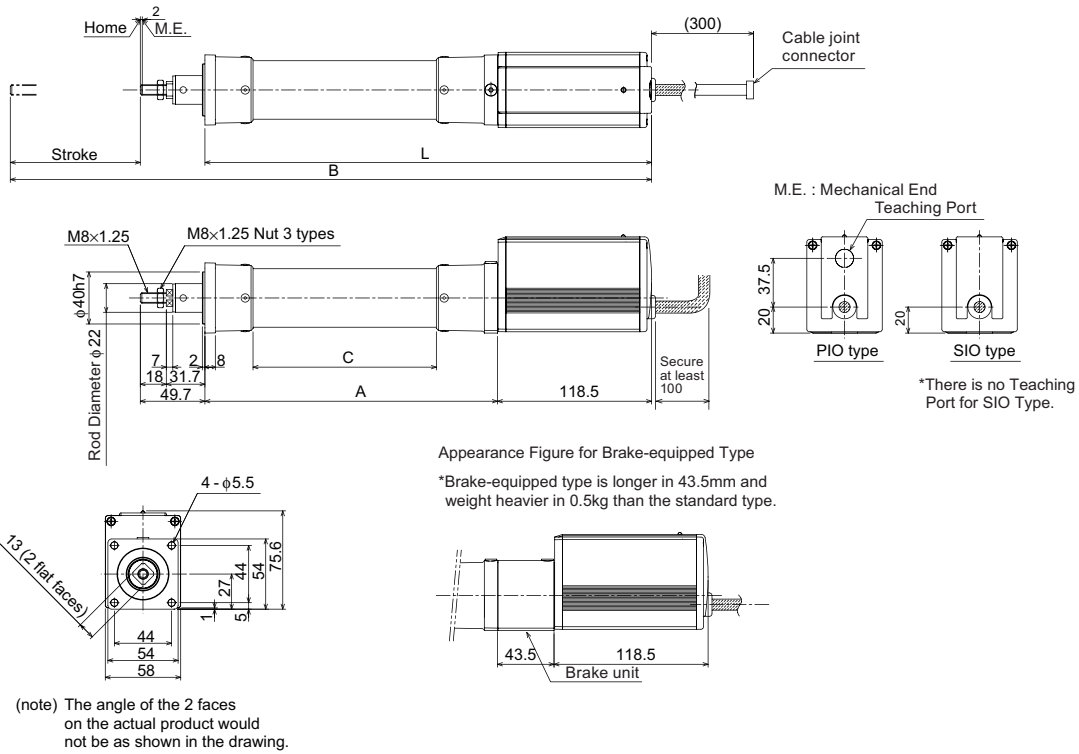

Stroke	50	100	150	200	250	300
L	293.5	343.5	393.5	443.5	493.5	543.5
A	175	225	275	325	375	425
B	393.2	493.2	593.2	693.2	793.2	893.2
C	91	141	191	241	291	341
Weight [kg]	1.6	1.7	1.8	2.0	2.1	2.2

11.1.4 ERC2-RA7C

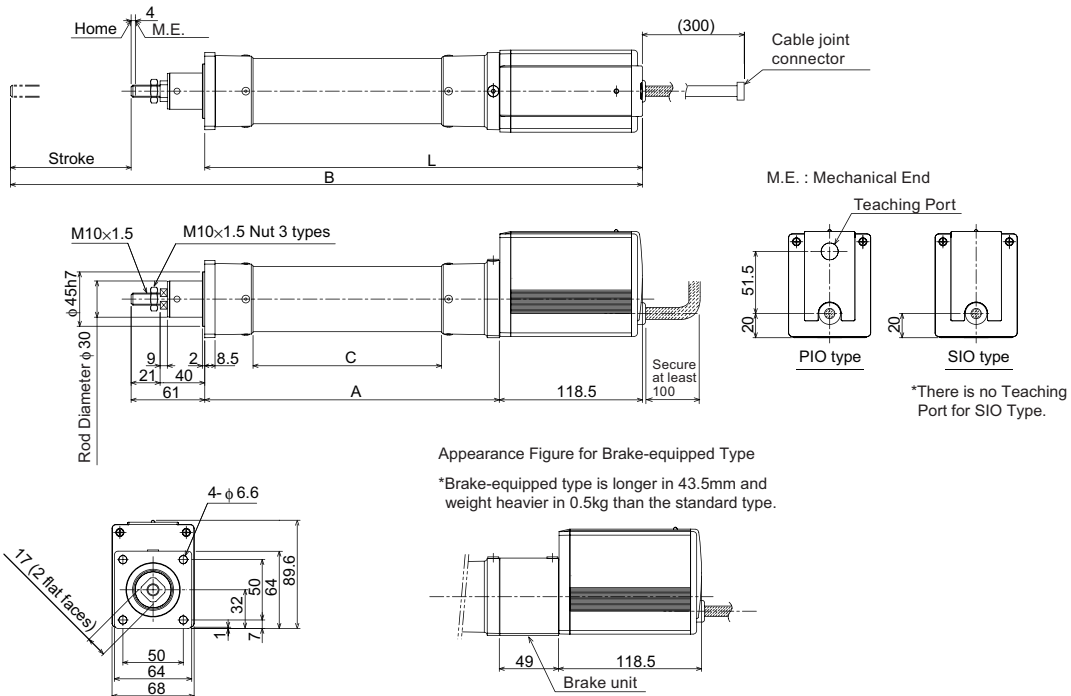

(note) The angle of the 2 faces on the actual product would not be as shown in the drawing.

Stroke	50	100	150	200	250	300
L	312.5	362.5	412.5	462.5	512.5	562.5
A	194	244	294	344	394	444
B	423.5	523.5	623.5	723.5	823.5	923.5
C	106	156	206	256	306	356
Weight [kg]	2.7	2.9	3.0	3.2	3.3	3.5

11.1.5 ERC2-RGS6C

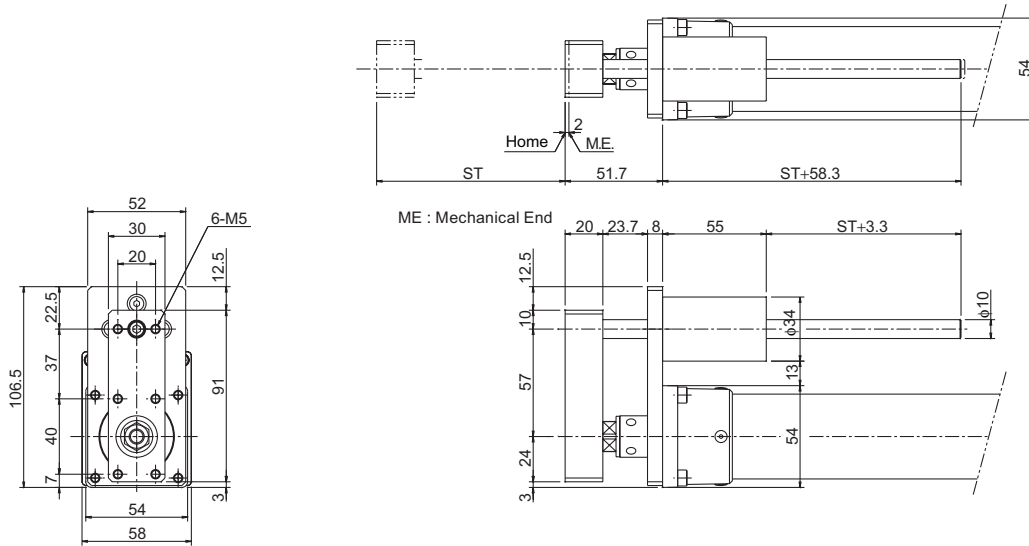

Stroke	50	100	150	200	250	300
Guide Weight [kg]	0.2	0.2	0.3	0.3	0.3	0.4
Weight of Guide + Main Unit [kg]	1.8	1.9	2.1	2.3	2.4	2.6

11.1.6 ERC2-RGS7C

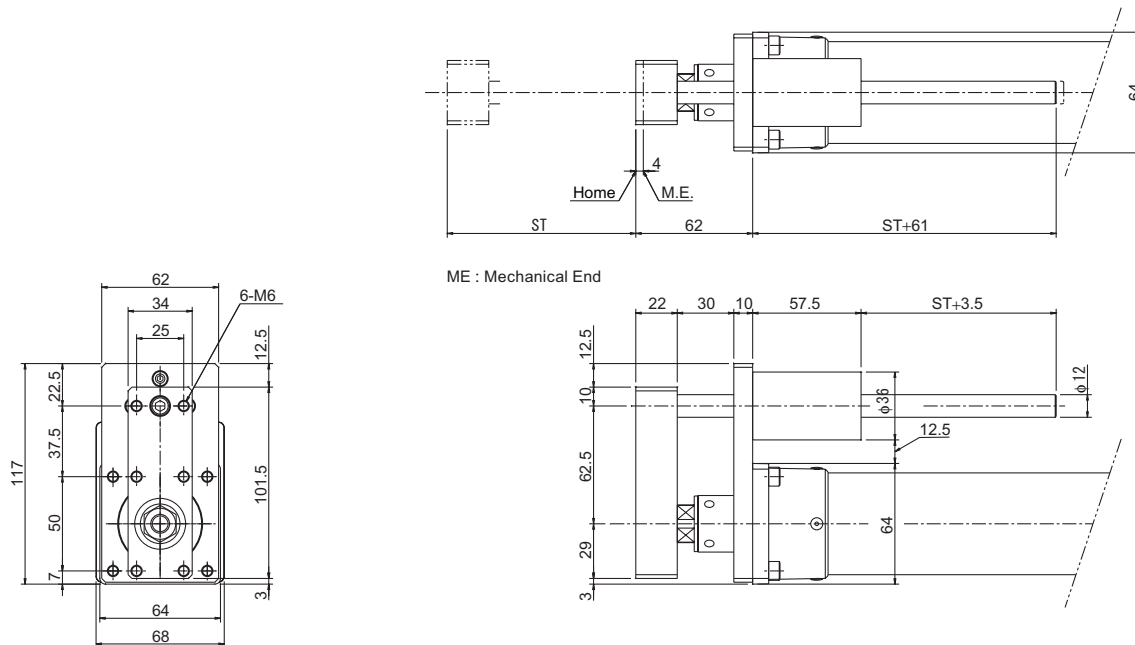

Stroke	50	100	150	200	250	300
Guide Weight [kg]	0.3	0.3	0.4	0.4	0.5	0.5
Weight of Guide + Main Unit [kg]	3.0	3.2	3.4	3.6	3.8	4.0

11.1.7 ERC2-RGD6C

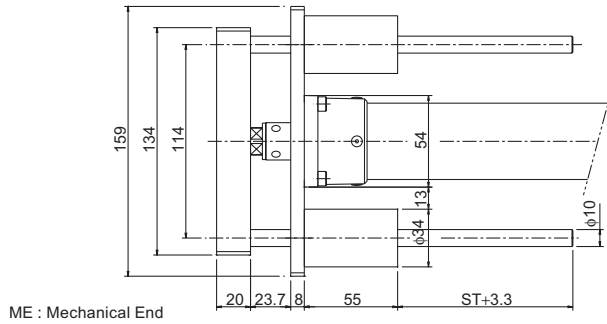
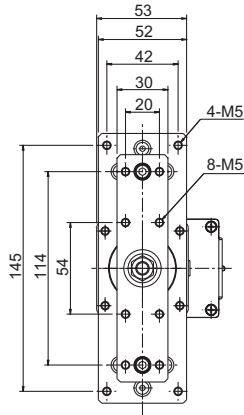

ME : Mechanical End

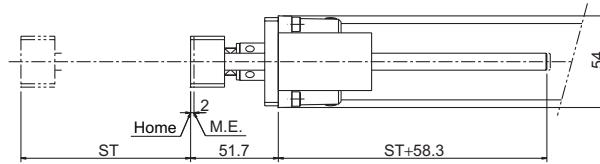

Stroke	50	100	150	200	250	300
Guide Weight [kg]	0.4	0.4	0.5	0.6	0.6	0.7
Weight of Guide + Main Unit [kg]	2.0	2.1	2.3	2.6	2.7	2.9

11.1.8 ERC2-RGD7C

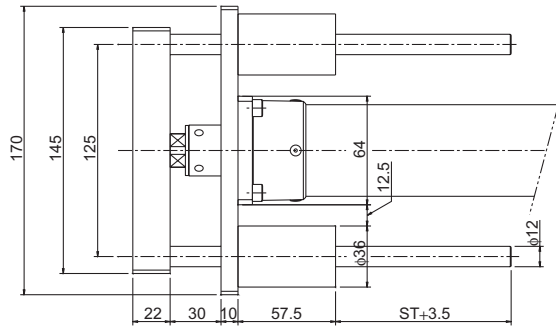
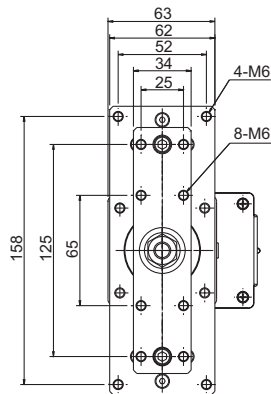

ME : Mechanical End

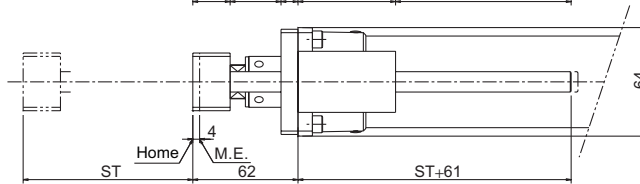

Stroke	50	100	150	200	250	300
Guide Weight [kg]	0.5	0.6	0.7	0.8	0.9	1.0
Weight of Guide + Main Unit [kg]	3.2	3.5	3.7	4.0	4.2	4.5

11.2 Example of Basic ERC2 Positioning Sequence

Given below is an example of basic sequence for creating a positioning sequence using the ERC2.
 ■ indicates PIO signals of the ERC2 controller.

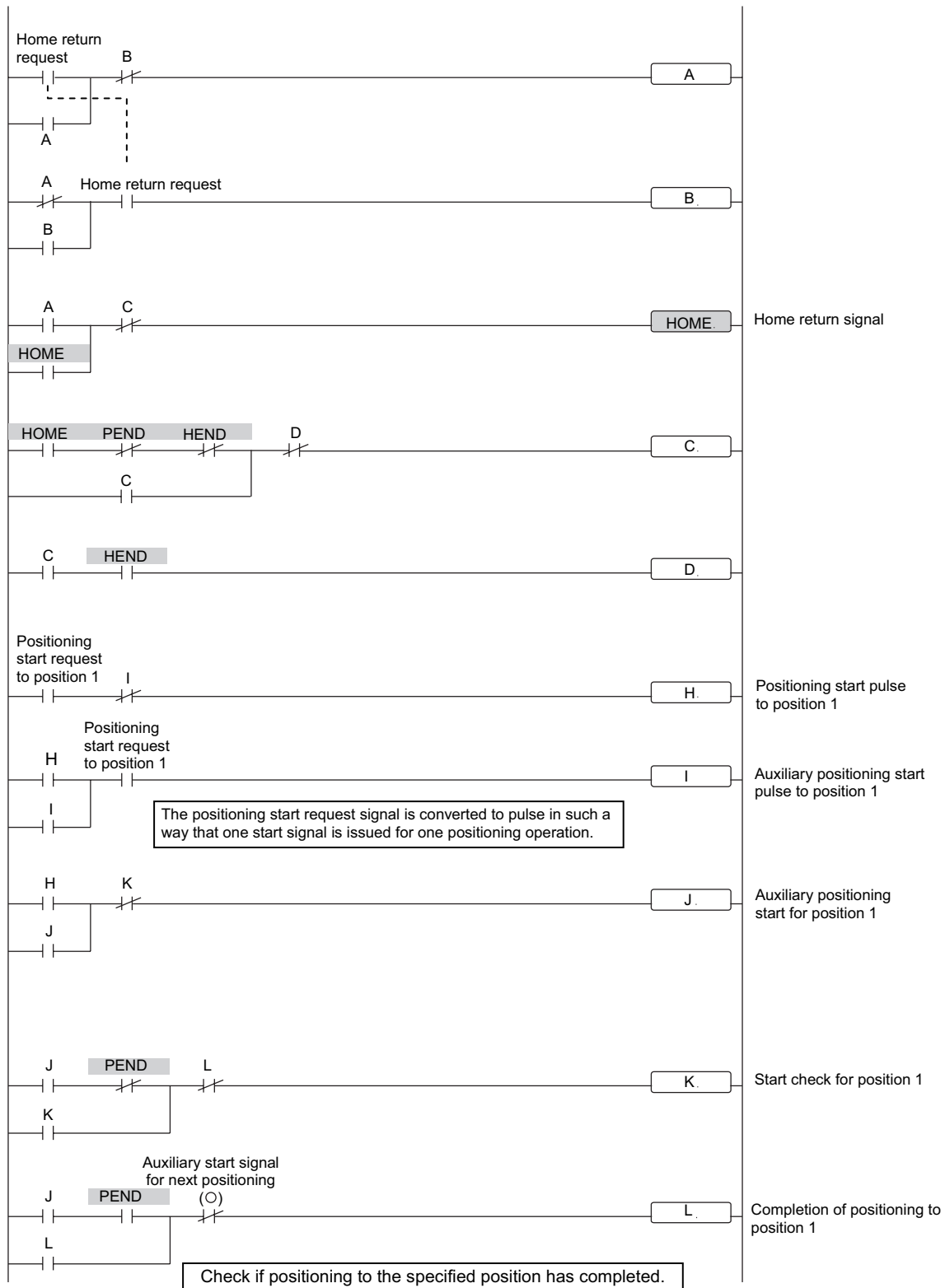

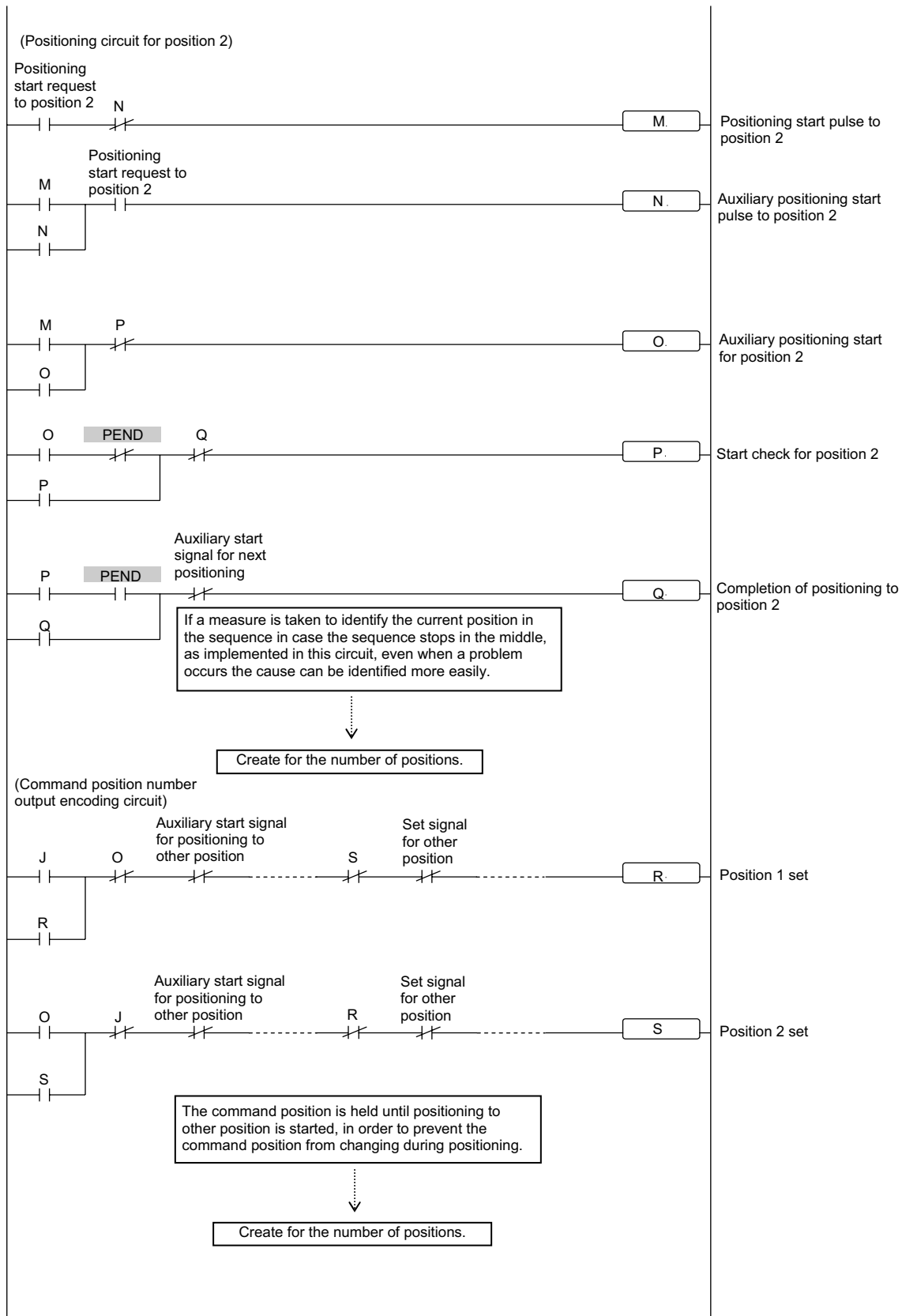

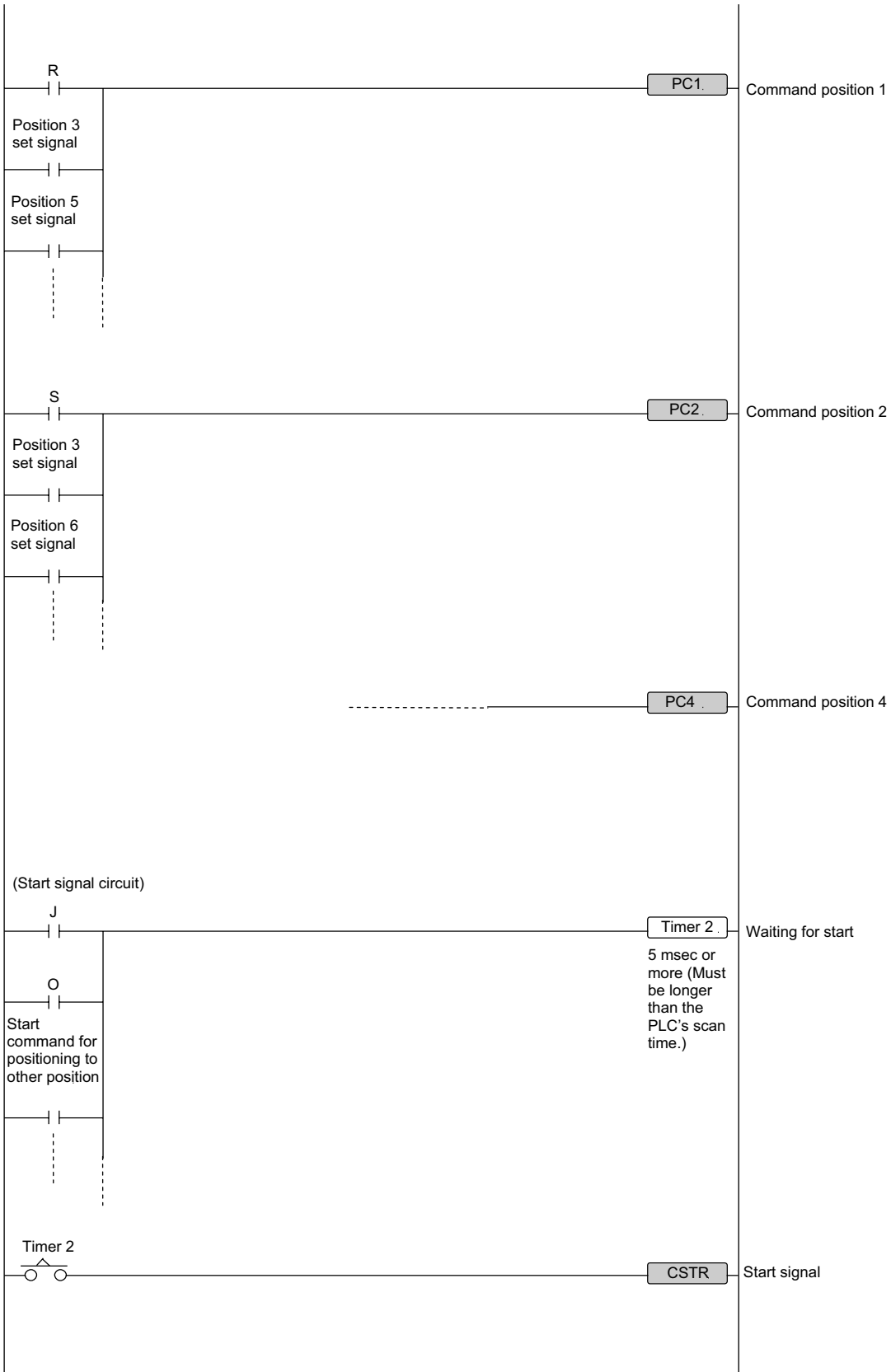

11.3 Recording of Position Table

Recorded date: _____

No.	Position [mm]	Speed [mm/s]	Acceleration [G]	Deceleration [G]	Push [%]	Threshold [%]	Positioning band [mm]	Zone+ [mm]	Zone- [mm]	Acceleration/ deceleration mode	Incremental	Command mode	Standstill mode
1													
2													
3													
4													
5													
6													
7													
8													
9													
10													
11													
12													
13													
14													
15													

11.4 Parameter Records

Recorded date: _____

- Category:
- a: Parameter relating to the actuator stroke range
 - b: Parameter relating to the actuator operating characteristics
 - c: Parameter relating to the external interface
 - d: Servo gain adjustment

No.	Category	Name	Unit	Recorded data
1	a	Zone boundary 1+	mm	
2	a	Zone boundary 1-	mm	
3	a	Soft limit+	mm	
4	a	Soft limit-	mm	
5	a	Home return direction (0: [Reverse]/1: [Forward])	-	
6	b	Push & hold stop judgment period	msec	
7	d	Servo gain number	-	
8	b	Default speed	mm/sec	
9	b	Default acceleration/deceleration	G	
10	b	Default positioning band (in-position)	mm	
12	b	Current-limiting value at standstill during positioning	%	
13	b	Current-limiting value during home return	%	
15	c	Pause input disable selection (0: [Enable]/1: [Disable])	-	
16	c	SIO communication speed	bps	
17	c	Minimum delay time for slave transmitter activation	msec	
22	a	Home return offset	mm	
25	c	PIO pattern selection	-	
27	c	Movement command type (0: [Level]/1: [Edge])	-	
28	b	Default direction of excited-phase signal detection (0: [Reverse]/1: [Forward])	-	
29	b	Excited-phase signal detection time	msec	
31	d	Speed loop proportional gain	-	
32	d	Speed loop integral gain	-	
33	d	Torque filter time constant	-	
34	b	Push speed	mm/sec	
35	b	Safety speed	mm/sec	
36	b	Automatic servo-off delay time 1	sec	
37	b	Automatic servo-off delay time 2	sec	
38	b	Automatic servo-off delay time 3	sec	
39	c	Output mode of position complete signal (0: [PEND]/1: [INP])	-	
40	c	Home-return input disable selection (0: [Enable]/1: [Disable])	-	
45	c	Silent interval multiplication factor	times	
46	b	Speed override	%	
53	b	Default standstill mode	-	

Change History

Revision Date	Description of Revision
January 2011	Third edition <ul style="list-style-type: none"> • Added "Before Use." • Changed "Safety Precautions" to "Safety Guide." • P. 6: Added 1.3.3, "The sound pressure level of this product does not exceed 70 dB." • P. 13: Moved "Prohibitions/Notes on Handling Cables" to after 1.7, "Wiring." • P. 133: Changed the description relating to the speed loop integral gain.
April 2011	Fourth edition <ul style="list-style-type: none"> • A page for CE Marking added
March 2012	Fifth edition <ul style="list-style-type: none"> • P. 1 to 7: Contents added and changed in Safety Guide • P. 8: Caution in Handling added • P. 15, 16: Contents changed in 1.4 Warranty • P. 155 to 158: Warning notes added such as in case the grease got into your eye, immediately go to see the doctor for an appropriate care. • P. 161 to 166: Weight added to appearance drawing
June 2015	5C edition <ul style="list-style-type: none"> • P. 23: Change made in caution note for connection to controller • P. 155: Grease change due to production stop Albania Grease No.2 → Albania Grease S2 Mobilax 2 → UNIREX N2
December 2015	5D edition <ul style="list-style-type: none"> • P. 72: External view of RCB-TU-PIO-A/B and RCB-TU-PIO-AP/BP integrated to external view of earthing/grounding as they have the same appearance



IAI Corporation

Head Office: 577-1 Obane Shimizu-KU Shizuoka City Shizuoka 424-0103, Japan
TEL +81-54-364-5105 FAX +81-54-364-2589
website: www.iai-robot.co.jp/

Technical Support available in USA, Europe and China

IAI America, Inc.

Head Office: 2690 W. 237th Street, Torrance, CA 90505
TEL (310) 891-6015 FAX (310) 891-0815
Chicago Office: 110 East State Parkway, Schaumburg, IL 60173
TEL (847) 908-1400 FAX (847) 908-1399
Atlanta Office: 1220 Kennestone Circle, Suite 108, Marietta, GA 30066
TEL (678) 354-9470 FAX (678) 354-9471
website: www.intelligentactuator.com

IAI Industrieroboter GmbH

Ober der Röth 4, D-65824 Schwalbach am Taunus, Germany
TEL 06196-88950 FAX 06196-889524

IAI (Shanghai) Co., Ltd.

SHANGHAI JIAHUA BUSINESS CENTER A8-303, 808, Hongqiao Rd. Shanghai 200030, China
TEL 021-6448-4753 FAX 021-6448-3992
website: www.iai-robot.com

IAI Robot (Thailand) Co., Ltd.

825 PhairojKijja Tower 12th Floor, Bangna-Trad RD., Bangna, Bangkok 10260, Thailand
TEL +66-2-361-4458 FAX +66-2-361-4456