

# Simple Absolute Unit

## Operation Manual Eleventh Edition

ACON  
PCON  
PSEL

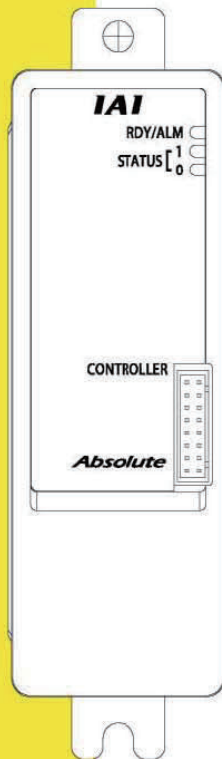

***IAI America, Inc.***



## Please Read Before Use

Thank you for purchasing our product.

This Operation Manual explains the handling methods, structure and maintenance of this product, among others, providing the information you need to know to use the product safely.

Before using the product, be sure to read this manual and fully understand the contents explained herein to ensure safe use of the product.

The CD/DVD that comes with the product contains operation manuals for IAI products.

When using the product, refer to the necessary portions of the applicable operation manual by printing them out or displaying them on a PC.

After reading the Operation Manual, keep it in a convenient place so that whoever is handling this product can reference it quickly when necessary.

### [Important]

- This Operation Manual is original.
- The product cannot be operated in any way unless expressly specified in this Operation Manual. IAI shall assume no responsibility for the outcome of any operation not specified herein.
- Information contained in this Operation Manual is subject to change without notice for the purpose of product improvement.
- If you have any question or comment regarding the content of this manual, please contact the IAI sales office near you.
- Using or copying all or part of this Operation Manual without permission is prohibited.
- The company names, names of products and trademarks of each company shown in the sentences are registered trademarks.



## 1. Controller Versions Supporting the Simple Absolute Unit

The simple absolute unit can be connected to controllers of the following firmware versions or higher:

ACON-C/CG: Ver. D

ACON-CY/SE: Ver. B

PCON: Ver. B

PSEL: Ver. 0.19

\* ACON-PL/PO and PCON-PL/PO controllers do not support the simple absolute unit.

\* When connecting to a controller of an older version, please contact IAI.

## 2. Actuators Not Supporting the Absolute Unit

RA10C and RCL

The simple absolute unit cannot be connected to the actuators mentioned above.

## 3. Charging the Battery

Always charge the battery when the simple absolute unit is started for the first time after the delivery, or after the battery has been replaced.

The battery in the simple absolute unit is charged automatically while the power is supplied to the controller, so keep the main power on for at least 72 hours. (The STATUS0 lamp will illuminate in green when the battery has been fully charged.)

The actuator can be moved and its position table changed while the battery is charged. If the power has been cut off for an extended period (not exceeding the specified backup time), also charge the battery for at least 72 hours.

## 4. When the Power Is Cut Off

- (1) Absolute data may be lost if the actuator receives vibration, shock, etc., or the slider, etc., is moved while the power is cut off.

When you turn on the power the next time, an absolute encoder error may generate, indicated by a green RDY/ALM lamp and red STATUS1 lamp. In this case, you must reset the alarm and perform home return.

While the power is cut off, do not move the slider or rod at a speed greater than the specified speed.

- (2) While the battery is charged, the surrounding air temperature affects the charge efficiency. It is recommended that the surrounding air temperature be kept to normal temperature (+10 to +30°C) while the battery is charged.

If the surrounding air temperature exceeds 45°C, the charge efficiency will drop and the battery will not be charged sufficiently. An excessively high surrounding air temperature during charge may also lead to performance degradation or leakage of battery fluid.

## 5. Caution on Parameter Change

If any of the following parameters is changed, an absolute error will generate. You must perform an absolute reset again after these parameters have been changed:

- ACON or PCON

- (1) Parameter No. 5: Home return direction
- (2) Parameter No. 22: Home return offset
- (3) Parameter No. 77: Ball screw lead
- (4) Parameter No. 78: Axis operation type

- PSEL

- |                                    |                                     |
|------------------------------------|-------------------------------------|
| (1) Axis-specific parameter No. 1  | (10) Axis-specific parameter No. 44 |
| (2) Axis-specific parameter No. 6  | (11) Axis-specific parameter No. 46 |
| (3) Axis-specific parameter No. 10 | (12) Axis-specific parameter No. 47 |
| (4) Axis-specific parameter No. 11 | (13) Axis-specific parameter No. 50 |
| (5) Axis-specific parameter No. 12 | (14) Axis-specific parameter No. 51 |
| (6) Axis-specific parameter No. 21 | (15) Axis-specific parameter No. 66 |
| (7) Axis-specific parameter No. 38 | (16) Axis-specific parameter No. 67 |
| (8) Axis-specific parameter No. 42 | (17) Axis-specific parameter No. 68 |
| (9) Axis-specific parameter No. 43 | (18) Driver parameter No. 26        |

## **CE Marking**

If a compliance with the CE Marking is required, please follow Overseas Standards Compliance Manual (ME0287) that is provided separately.



## Table of Contents

Safety Guide.....	1
1. Overview .....	1
1.1 Introduction .....	1
1.2 How to Read the Model Name.....	2
1.3 Handling the Battery of the Absolute Unit.....	3
1.4 Safety Precautions.....	4
1.5 Warranty .....	5
2. Specifications .....	7
2.1 Basic Specifications .....	7
2.1.1 Backup Battery.....	8
2.2 Name and Function of Each Controller Part.....	9
2.2.1 Names.....	9
2.2.2 Functions.....	10
2.3 External Dimensions .....	12
3. Installation and Noise Elimination .....	13
3.1 Installation Environment.....	13
3.2 Supplied Power.....	13
3.3 Noise Elimination and Grounding .....	13
3.4 Heat Dissipation and Installation .....	15
4. Wiring .....	16
4.1 Configuration.....	16
4.2 Connecting the Dedicated Cable .....	17
4.2.1 PCON/PSEL Controller Cable .....	17
4.2.2 ACON Controller Cable.....	18
4.3 How to Open the Lid of the Simple Absolute Unit.....	19
4.4 Wiring the Power Supply .....	20
5. Operation .....	21
5.1 Startup Procedure .....	21
5.1.1 Piano Switch Settings .....	21
5.1.2 Parameter Setting (High-Order Controller).....	22
5.2 How to Perform an Absolute Reset.....	23
5.2.1 Absolute Reset Using PIO Signals .....	23
5.2.2 Absolute Reset from the PC Software .....	24
5.2.3 Absolute Reset from the Teaching Pendant .....	30
5.3 Replacing the Battery.....	31
6. Troubleshooting.....	33
6.1 What to Do When a Problem Occurs.....	33
6.2 Alarm Classification by Level.....	35
6.3 Alarms, Causes and Actions.....	36
Change History .....	40



## Safety Guide

When designing and manufacturing a robot system, ensure safety by following the safety precautions provided below and taking the necessary measures.

### Regulations and Standards Governing Industrial Robots

Safety measures on mechanical devices are generally classified into four categories under the International Industrial Standard ISO/DIS 12100, "Safety of machinery," as follows:

- Safety measures — Inherent safety design
- Protective guards --- Safety fence, etc.
- Additional safety measures --- Emergency stop device, etc.
- Information on use --- Danger sign, warnings, operation manual

Based on this classification, various standards are established in a hierarchical manner under the International Standards ISO/IEC. The safety standards that apply to industrial robots are as follows:

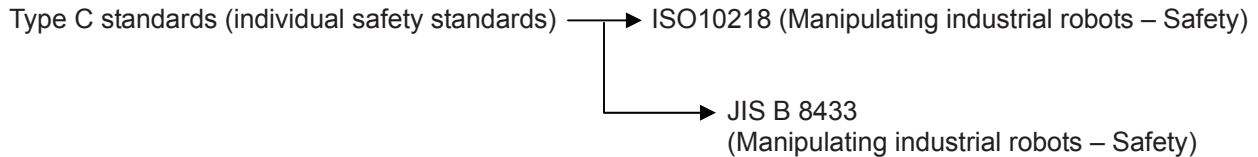

Also, Japanese laws regulate the safety of industrial robots, as follows:

#### Industrial Safety and Health Law Article 59

Workers engaged in dangerous or harmful operations must receive special education.

#### Ordinance on Industrial Safety and Health

Article 36 --- Operations requiring special education

- No. 31 (Teaching, etc.) --- Teaching and other similar work involving industrial robots (exceptions apply)
- No. 32 (Inspection, etc.) --- Inspection, repair, adjustment and similar work involving industrial robots (exceptions apply)

Article 150 --- Measures to be taken by the user of an industrial robot

## Requirements for Industrial Robots under Ordinance on Industrial Safety and Health

Work area	Work condition	Cutoff of drive source	Measure	Article
Outside movement range	During automatic operation	Not cut off	Signs for starting operation	Article 104
			Installation of railings, enclosures, etc.	Article 150-4
Inside movement range	During teaching, etc.	Cut off (including stopping of operation)	Sign, etc., indicating that work is in progress	Article 150-3
		Not cut off	Preparation of work rules	Article 150-3
			Measures to enable immediate stopping of operation	Article 150-3
			Sign, etc., indicating that work is in progress	Article 150-3
			Provision of special education	Article 36-31
			Checkup, etc., before commencement of work	Article 151
	During inspection, etc.	Cut off	To be performed after stopping the operation	Article 150-5
			Sign, etc., indicating that work is in progress	Article 150-5
		Not cut off (when inspection, etc., must be performed during operation)	Preparation of work rules	Article 150-5
			Measures to enable immediate stopping of operation	Article 150-5
			Sign, etc., indicating that work is in progress	Article 150-5
			Provision of special education (excluding cleaning and lubrication)	Article 36-32

## Applicable Models of IAI's Industrial Robots

Machines meeting the following conditions are not classified as industrial robots according to Notice of Ministry of Labor No. 51 and Notice of Ministry of Labor/Labor Standards Office Director (Ki-Hatsu No. 340):

- (1) Single-axis robot with a motor wattage of 80 W or less
- (2) Combined multi-axis robot whose X, Y and Z-axes are 300 mm or shorter and whose rotating part, if any, has the maximum movement range of within 300 mm<sup>3</sup> including the tip of the rotating part
- (3) Multi-joint robot whose movable radius and Z-axis are within 300 mm

Among the products featured in our catalogs, the following models are classified as industrial robots:

1. Single-axis ROBO Cylinders  
RCS2/RCS2CR-SS8□ whose stroke exceeds 300 mm
2. Single-axis robots  
The following models whose stroke exceeds 300 mm and whose motor capacity also exceeds 80 W:  
ISA/ISPA, ISDA/ISPDA, ISWA/ISPWA, IF, FS, NS
3. Linear servo actuators  
All models whose stroke exceeds 300 mm
4. Cartesian robots  
Any robot that uses at least one axis corresponding to one of the models specified in 1 to 3
5. IX SCARA robots  
All models whose arm length exceeds 300 mm  
(All models excluding IX-NNN1205/1505/1805/2515, NNW2515 and NNC1205/1505/1805/2515)

## Notes on Safety of Our Products

Common items you should note when performing each task on any IAI robot are explained below.

No.	Task	Note
1	Model selection	<ul style="list-style-type: none"> <li>● This product is not planned or designed for uses requiring high degrees of safety. Accordingly, it cannot be used to sustain or support life and must not be used in the following applications:               <ul style="list-style-type: none"> <li>[1] Medical devices relating to maintenance, management, etc., of life or health</li> <li>[2] Mechanisms or mechanical devices (vehicles, railway facilities, aircraft facilities, etc.) intended to move or transport people</li> <li>[3] Important safety parts in mechanical devices (safety devices, etc.)</li> </ul> </li> <li>● Do not use this product in the following environments:               <ul style="list-style-type: none"> <li>[1] Place subject to flammable gases, ignitable objects, flammables, explosives, etc.</li> <li>[2] Place that may be exposed to radiation</li> <li>[3] Place where the surrounding air temperature or relative humidity exceeds the specified range</li> <li>[4] Place subject to direct sunlight or radiated heat from large heat sources</li> <li>[5] Place subject to sudden temperature shift and bedewing</li> <li>[6] Place subject to corrosive gases (sulfuric acid, hydrochloric acid, etc.)</li> <li>[7] Place subject to excessive dust, salt or iron powder</li> <li>[8] Place where the product receives direct vibration or impact</li> </ul> </li> <li>● Do not use this product outside the specified ranges. Doing so may significantly shorten the life of the product or result in product failure or facility stoppage.</li> </ul>
2	Transportation	<ul style="list-style-type: none"> <li>● When transporting the product, exercise due caution not to bump or drop the product.</li> <li>● Use appropriate means for transportation.</li> <li>● Do not step on the package.</li> <li>● Do not place on the package any heavy article that may deform the package.</li> <li>● When using a crane with a capacity of 1 ton or more, the crane must be operated by personnel qualified to operate cranes and perform slinging operations.</li> <li>● When using a crane or other equipment, never use it to hoist any article exceeding the rated load of the applicable crane, etc.</li> <li>● Use hoisting accessories suitable for the article to be hoisted. Select appropriate hoisting accessories by making sure there is an ample allowance for safety in their cutting load, etc.</li> <li>● Do not climb onto the article being hoisted.</li> <li>● Do not keep the article hoisted.</li> <li>● Do not stand under the hoisted article.</li> </ul>
3	Storage, preservation	<ul style="list-style-type: none"> <li>● The storage, preservation environment should conform to the installation environment. Among others, be careful not to cause bedewing.</li> </ul>





No.	Task	Note
4	Installation/ startup	<p>(1) Installing the robot, controller, etc.</p> <ul style="list-style-type: none"> <li>● Be sure to firmly secure and affix the product (including its load). If the product tips over, drops, malfunctions, etc., damage or injury may result.</li> <li>● Do not step on the product or place any article on top. The product may tip over or the article may drop, resulting in injury, product damage, loss of/drop in product performance, shorter life, etc.</li> <li>● If the product is used in any of the following places, provide sufficient shielding measures: <ul style="list-style-type: none"> <li>[1] Place subject to electrical noise</li> <li>[2] Place subject to a strong electric or magnetic field</li> <li>[3] Place where power lines or drive lines are wired nearby</li> <li>[4] Place subject to splashed water, oil or chemicals</li> </ul> </li> </ul> <p>(2) Wiring the cables</p> <ul style="list-style-type: none"> <li>● Use IAI's genuine cables to connect the actuator and controller or connect a teaching tool, etc.</li> <li>● Do not damage, forcibly bend, pull, loop round an object or pinch the cables or place heavy articles on top. Current leak or poor electrical continuity may occur, resulting in fire, electric shock or malfunction.</li> <li>● Wire the product correctly after turning off the power.</li> <li>● When wiring a DC power supply (+24 V), pay attention to the positive and negative polarities. Connecting the wires in wrong polarities may result in fire, product failure or malfunction.</li> <li>● Be sure to connect the cable connectors without fail and firmly. Failing to do so may result in fire, electric shock or product malfunction.</li> <li>● Do not cut and reconnect the cables of the product to extend or shorten the cables. Doing so may result in fire or product malfunction.</li> </ul> <p>(3) Grounding</p> <ul style="list-style-type: none"> <li>● Be sure to provide class D (former class 3) grounding for the controller. Grounding is required to prevent electric shock and electrostatic charges, improve noise resistance and suppress unnecessary electromagnetic radiation.</li> </ul> <p>(4) Safety measures</p> <ul style="list-style-type: none"> <li>● Implement safety measures (such as installing safety fences, etc.) to prevent entry into the movement range of the robot when the product is moving or can be moved. Contacting the moving robot may result in death or serious injury.</li> <li>● Be sure to provide an emergency stop circuit so that the product can be stopped immediately in case of emergency during operation.</li> </ul>

No.	Task	Note
4	Installation/ startup	<ul style="list-style-type: none"> <li>● Implement safety measures so that the product cannot be started only by turning on the power. If the product starts suddenly, injury or product damage may result.</li> <li>● Implement safety measures so that the product will not start upon cancellation of an emergency stop or recovery of power following a power outage. Failure to do so may result in injury, equipment damage, etc.</li> <li>● Put up a sign saying "WORK IN PROGRESS. DO NOT TURN ON POWER," etc., during installation, adjustment, etc. If the power is accidentally turned on, electric shock or injury may result.</li> <li>● Implement measures to prevent the load, etc., from dropping due to a power outage or emergency stop.</li> <li>● Ensure safety by wearing protective gloves, protective goggles and/or safety shoes, as necessary.</li> <li>● Do not insert fingers and objects into openings in the product. Doing so may result in injury, electric shock, product damage, fire, etc.</li> <li>● When releasing the brake of a vertically installed actuator, be careful not to pinch your hand or damage the work, etc., due to the slider dropping by its dead weight.</li> </ul>
5	Teaching	<ul style="list-style-type: none"> <li>● Whenever possible, perform teaching from outside the safety fences. If teaching must be performed inside the safety fences, prepare "work rules" and make sure the operator understands the procedures thoroughly.</li> <li>● When working inside the safety fences, the operator should carry a handy emergency stop switch so that the operation can be stopped any time when an abnormality occurs.</li> <li>● When working inside the safety fences, appoint a safety watcher in addition to the operator so that the operation can be stopped any time when an abnormality occurs. The safety watcher must also make sure the switches are not operated inadvertently by a third party.</li> <li>● Put up a sign saying "WORK IN PROGRESS" in a conspicuous location.</li> <li>● When releasing the brake of a vertically installed actuator, be careful not to pinch your hand or damage the work, etc., due to the slider dropping by its dead weight.</li> </ul> <p>* Safety fences --- Indicate the movement range if safety fences are not provided.</p>
6	Confirmation operation	<ul style="list-style-type: none"> <li>● After teaching or programming, carry out step-by-step confirmation operation before switching to automatic operation.</li> <li>● When carrying out confirmation operation inside the safety fences, follow the specified work procedure just like during teaching.</li> <li>● When confirming the program operation, use the safety speed. Failure to do so may result in an unexpected movement due to programming errors, etc., causing injury.</li> <li>● Do not touch the terminal blocks and various setting switches while the power is supplied. Touching these parts may result in electric shock or malfunction.</li> </ul>

No.	Task	Note
7	Automatic operation	<ul style="list-style-type: none"> <li>● Before commencing automatic operation, make sure no one is inside the safety fences.</li> <li>● Before commencing automatic operation, make sure all related peripherals are ready to operate in the auto mode and no abnormalities are displayed or indicated.</li> <li>● Be sure to start automatic operation from outside the safety fences.</li> <li>● If the product generated abnormal heat, smoke, odor or noise, stop the product immediately and turn off the power switch. Failure to do so may result in fire or product damage.</li> <li>● If a power outage occurred, turn off the power switch. Otherwise, the product may move suddenly when the power is restored, resulting in injury or product damage.</li> </ul>
8	Maintenance/ inspection	<ul style="list-style-type: none"> <li>● Whenever possible, work from outside the safety fences. If work must be performed inside the safety fences, prepare “work rules” and make sure the operator understands the procedures thoroughly.</li> <li>● When working inside the safety fences, turn off the power switch, as a rule.</li> <li>● When working inside the safety fences, the operator should carry a handy emergency stop switch so that the operation can be stopped any time when an abnormality occurs.</li> <li>● When working inside the safety fences, appoint a safety watcher in addition to the operator so that the operation can be stopped any time when an abnormality occurs. The safety watcher must also make sure the switches are not operated inadvertently by a third party.</li> <li>● Put up a sign saying “WORK IN PROGRESS” in a conspicuous location.</li> <li>● Use appropriate grease for the guides and ball screws by checking the operation manual for each model.</li> <li>● Do not perform a withstand voltage test. Conducting this test may result in product damage.</li> <li>● When releasing the brake of a vertically installed actuator, be careful not to pinch your hand or damage the work, etc., due to the slider dropping by its dead weight.</li> </ul> <p>* Safety fences --- Indicate the movement range if safety fences are not provided.</p>
9	Modification	<ul style="list-style-type: none"> <li>● The customer must not modify or disassemble/assemble the product or use maintenance parts not specified in the manual without first consulting IAI.</li> <li>● Any damage or loss resulting from the above actions will be excluded from the scope of warranty.</li> </ul>
10	Disposal	<ul style="list-style-type: none"> <li>● When the product becomes no longer usable or necessary, dispose of it properly as an industrial waste.</li> <li>● When disposing of the product, do not throw it into fire. The product may explode or generate toxic gases.</li> </ul>

## Indication of Cautionary Information

The operation manual for each model denotes safety precautions under “Danger,” “Warning,” “Caution” and “Note,” as specified below.

Level	Degree of danger/loss	Symbol
Danger	Failure to observe the instruction will result in an imminent danger leading to death or serious injury.	 <b>Danger</b>
Warning	Failure to observe the instruction may result in death or serious injury.	 <b>Warning</b>
Caution	Failure to observe the instruction may result in injury or property damage.	 <b>Caution</b>
Note	The user should take heed of this information to ensure the proper use of the product, although failure to do so will not result in injury.	 <b>Note</b>

## 1. Overview

### 1.1 Introduction

Thank you for purchasing IAI's Simple Absolute Unit.

This simple absolute unit is designed exclusively for use with PCON/ACON/PSEL controllers. By connecting this unit to your PCON/ACON/PSEL controller, home return will no longer be necessary every time the controller power is turned off, as long as an absolute reset has been performed.

This manual explains the features and usage of this product.

As with any products, improper use or handling will prevent this product from fully demonstrating its designed function or may even cause the product to fail unexpectedly or prematurely. Read this manual carefully and fully understand the handling instructions explained herein, and operate the product correctly. Keep this manual with you, so that you can reference the applicable sections whenever necessary.

Also refer to the operation manual for each actuator. If you are using an optional PC software or teaching pendant, refer to its manual, as well.

## 1.2 How to Read the Model Name



Model name for each item

- Simple absolute unit:            ABU (battery included)
- Battery only:                    AB-7
- ACON connection cable:      CB-AC-PJ \*\*\*
- PCON/PSEL connection cable: CB-PC-PJ \*\*\*

\*\*\* indicates the cable length. Example) 002: 20 cm

Cable differentiation

- ACON connection cable:      Both connectors are red.
- PCON/PSEL connection cable: One connector is white, and the other is red.

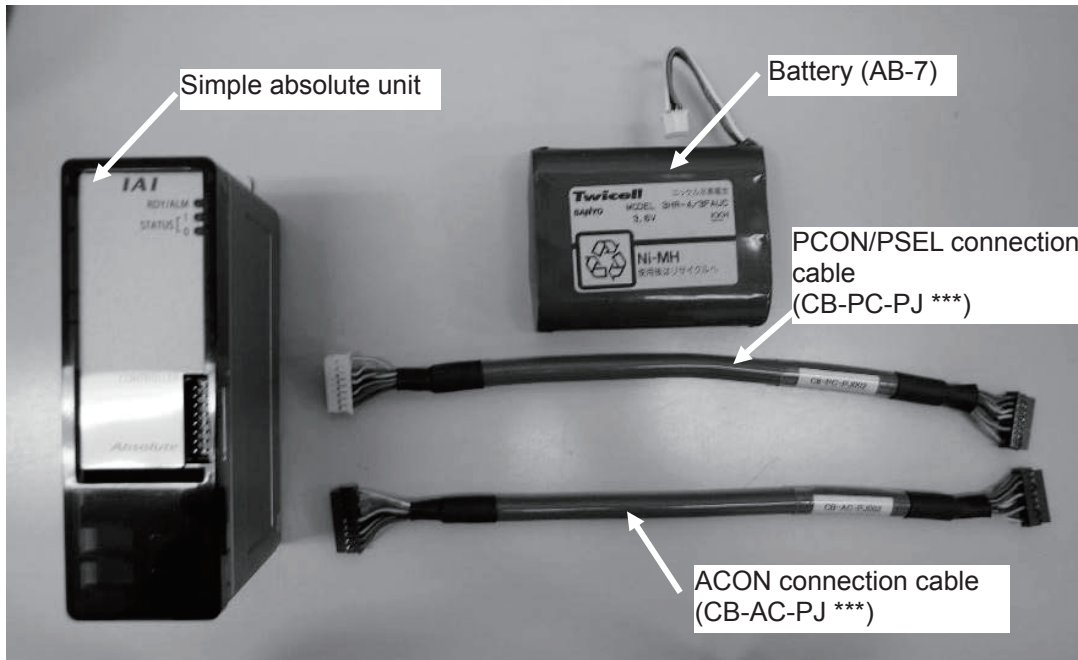

### 1.3 Handling the Battery of the Absolute Unit

Handle the battery by following the safety precautions specified below.

1. Never disassemble the battery. The electrolyte contained in the battery is a strong alkaline fluid that can damage the skin and clothes.
2. Never short the battery (by connecting its positive and negative terminals directly). The equipment may be damaged or generated heat may cause burns.
3. Never throw the battery into fire, as the battery may explode. Also avoid immersing the battery in water, as it may impair the battery function.
4. Do not apply solder directly onto the battery. The safety valve in the battery cap may be damaged, causing the safety mechanism to burst.
5. If the power is cut off for an extended period with the battery connector connected, the battery may enter a deep discharge state. As a result, battery fluid may leak or the battery life may become substantially shorter. If the power will be cut off for an extended period due to relocation or modification of the system, etc., unplug the battery connector.
6. When disposing of the battery, take proper measures such as placing it into the battery recycle box at an electrical appliance store, etc.

\* Utmost efforts have been made to ensure precision and completeness of this manual. Should you find any error, however, or if you have any comment regarding this manual, please contact IAI.  
Keep this manual in a convenient place so that you can readily reference it whenever necessary.

## 1.4 Safety Precautions

Read the following precautions carefully and give fullest attention to safety measures.

This system product has been developed as a drive part for automated machinery, etc., and is designed not to produce torque or speed beyond the levels needed to drive automated equipment. However, the following instructions must be strictly followed in order to prevent accidents.

1. Do not handle this product in any way not explained in this manual. If you have any question regarding the content of this manual, contact IAI.
2. Always use the specified genuine IAI cables for wiring the actuator and simple absolute unit.
3. Do not enter the operation area of the machine while the machine is operating or ready to operate (i.e., the controller power is turned on). If the machine is used in a location accessible to others, take proper measures such as enclosing the machine with a safety fence.
4. Always turn off the main power supply to the controller before carrying out any assembly, adjustment, maintenance or inspection work on the machine. While conducting such work, put up a sign to alert that work is in progress. Also, the operator should draw in the power cable and keep it nearby, so that other person will not connect the cable inadvertently.
5. If two or more persons work together, set action cues and confirm one another's safety before carrying out each step. When moving an axis, regardless of whether the power is turned on or off or it is done using the motor or manually, always call out to check on others and confirm that it is safe to move the axis.
6. Cable extension can be a cause of malfunction due to miswiring. If you must extend the wiring, check thoroughly and confirm that the product has been wired correctly before turning on the power.

## 1.5 Warranty

### 1. Warranty Period

One of the following periods, whichever is shorter:

- 18 months after the shipment from IAI' s factory
- 12 months after the delivery to the specified location

### 2. Scope of Warranty

Our products are covered by warranty when all of the following conditions are met. Faulty products covered by warranty will be replaced or repaired free of charge:

- (1) The breakdown or problem in question pertains to our product as delivered by us or our authorized dealer.
- (2) The breakdown or problem in question occurred during the warranty period.
- (3) The breakdown or problem in question occurred while the product was in use for an appropriate purpose under the conditions and environment of use specified in the operation manual and catalog.
- (4) The breakdown or problem in question was caused by a specification defect or problem, or by the poor quality of our product.

Note that breakdowns due to any of the following reasons are excluded from the scope of warranty:

- [1] Anything other than our product
- [2] Modification or repair performed by a party other than us (unless we have approved such modification or repair)
- [3] Anything that could not be easily predicted with the level of science and technology available at the time of shipment from our company
- [4] A natural disaster, man-made disaster, incident or accident for which we are not liable
- [5] Natural fading of paint or other symptoms of aging
- [6] Wear, depletion or other expected result of use
- [7] Operation noise, vibration or other subjective sensation not affecting function or maintenance

Note that the warranty only covers our product as delivered and that any secondary loss arising from a breakdown of our product is excluded from the scope of warranty.

### 3. Honoring Warranty

As a rule, the product must be brought to us for repair under warranty.

### 4. Limited Liability

- [1] We shall assume no liability for any special damage, consequential loss or passive loss such as a loss of expected profit arising from or in connection with our product.
- [2] We shall not be liable for any program or control method created by the customer to operate our product or for the result of such program or control method.

5. Conditions of Conformance with Applicable Standards/Regulations, Etc., and Applications
  - (1) If our product is combined with another product or any system, device, etc., used by the customer, the customer must first check the applicable standards, regulations and/or rules. The customer is also responsible for confirming that such combination with our product conforms to the applicable standards, etc. In such a case we will not be liable for the conformance of our product with the applicable standards, etc.
  - (2) Our product is for general industrial use. It is not intended or designed for the applications specified below, which require a high level of safety. Accordingly, as a rule our product cannot be used in these applications. Contact us if you must use our product for any of these applications:
    - [1] Medical equipment pertaining to maintenance or management of human life or health
    - [2] A mechanism or mechanical equipment intended to move or transport people (such as a vehicle, railway facility or aviation facility)
    - [3] Important safety parts of mechanical equipment (such as safety devices)
    - [4] Equipment used to handle cultural assets, art or other irreplaceable items
  - (3) Contact us at the earliest opportunity if our product is to be used in any condition or environment that differs from what is specified in the catalog or operation manual.
6. Other Items Excluded from Warranty

The price of the product delivered to you does not include expenses associated with programming, the dispatch of engineers, etc. Accordingly, a separate fee will be charged in the following cases even during the warranty period:

  - [1] Guidance for installation/adjustment and witnessing of test operation
  - [2] Maintenance and inspection
  - [3] Technical guidance and education on operating/wiring methods, etc.
  - [4] Technical guidance and education on programming and other items related to programs

## 2. Specifications

### 2.1 Basic Specifications

Model	ACON/PCON-ABU	
Power-supply voltage	24 VDC $\pm$ 10%	
Power-supply current	MAX 300 mA	
Environment	Surrounding air temperature	0~40°C
	Surrounding humidity	95% RH or below (non-condensing)
	Surrounding environment	Not containing corrosive gases or dust
	Ambient storage temperature	0~40°C (20°C is recommended, if the unit is stored together with the battery.)
	Ambient storage humidity	95% RH or below (non-condensing)
	Vibration resistance	In XYZ directions: 10 to 57 Hz --- Pulsating amplitude of 0.035 mm (continuous) or 0.075 mm (intermittent) 57 to 150 Hz --- 4.9 m/s <sup>2</sup> (continuous) or 9.8 m/s <sup>2</sup> (intermittent)
Shock resistance	In XYZ directions: 147 mm/s <sup>2</sup> , 11 ms, half-sine pulse	
Protection class	IP20	
Weight	312 g (battery included)	
External dimensions	34W X 120H X 75.3D mm (brackets included)	

## 2.1.1 Backup Battery

The absolute specification uses a secondary battery (nickel-hydrogen battery) to retain absolute counter data in the FPGA when the power is cut off, and also to supply the power intermittently to the encoder drive circuit.

### (1) Battery Specification

Item	Description
Type	Cylindrical sealed nickel-hydrogen battery
Manufacturer	FDK Corporation
Model	AB-7
Nominal voltage	3.6 V (1.2 V x 3)
Rated capacity	3300 mAh
Nominal capacity	3700 mAh
Average life	3 years
Weight	190 g
Charge time	Approx. 72 hours
Approx. backup time after cutoff of power	4 levels of 5, 10, 15 and 20 days

### (2) Charging the Battery

Always charge the battery when the simple absolute unit is started for the first time after the delivery, or after the battery has been replaced.

The battery in the simple absolute unit is charged automatically while the power is supplied to the controller, so keep the main power on for at least 72 hours.

The actuator can be moved and its position table changed while the battery is charged. If the power has been cut off for an extended period (not exceeding the specified backup time), also charge the battery for at least 72 hours.

\* For the specified backup time, refer to 5.1.1, "Piano Switch Settings."

### (3) Replacing the Battery

The battery is a consumable part, which means that its initial characteristics will deteriorate through repeated charging. If the backup time has become significantly shorter, the battery is reaching its life and must be replaced.

Although the exact timing of replacement varies depending on the surrounding air temperature and discharge condition, a rough guide is approximately three years after the battery is connected to the controller. The battery unit has a label attached to it, showing a date three years from the shipment. Use this date as a reference.

Caution: (1) Absolute data may be lost if the actuator receives vibration, shock, etc., or the slider, etc., is moved while the power is cut off.  
When you turn on the power the next time, an absolute encoder error may generate, indicated by a green RDY/ALM lamp and red STATUS1 lamp. In this case, you must reset the alarm and perform home return.  
While the power is cut off, do not move the slider or rod.

(2) While the battery is charged, the surrounding air temperature affects the charge efficiency. It is recommended that the surrounding air temperature be kept to normal temperature (+10 to +30°C) while the battery is charged.  
If the surrounding air temperature exceeds 45°C, the charge efficiency will drop and the battery will not be charged sufficiently. An excessively high surrounding air temperature during charge may also lead to performance degradation or leakage of battery fluid.

## 2.2 Name and Function of Each Controller Part

### 2.2.1 Names

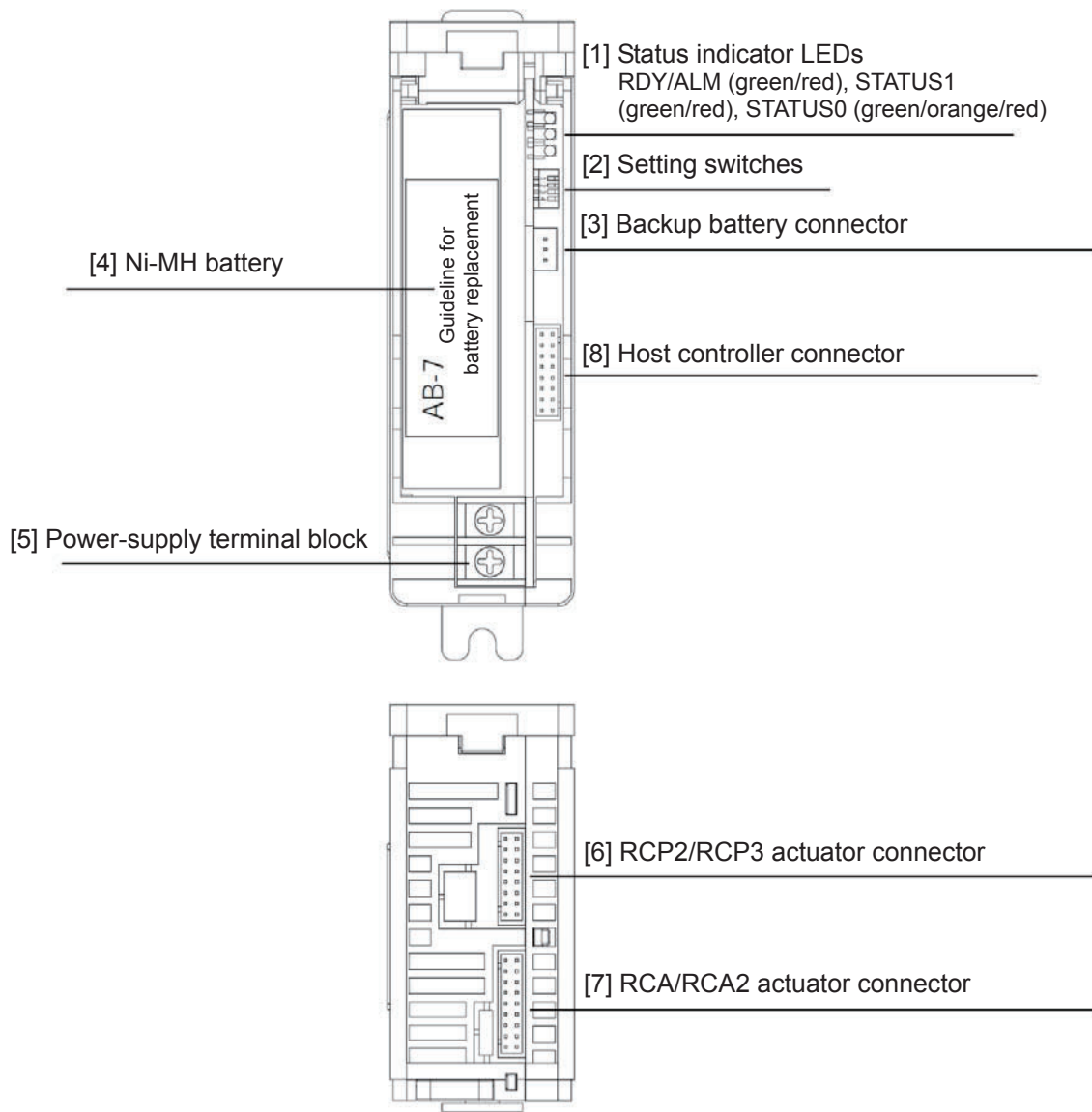

## 2.2.2 Functions

### [1] Status indicator LEDs

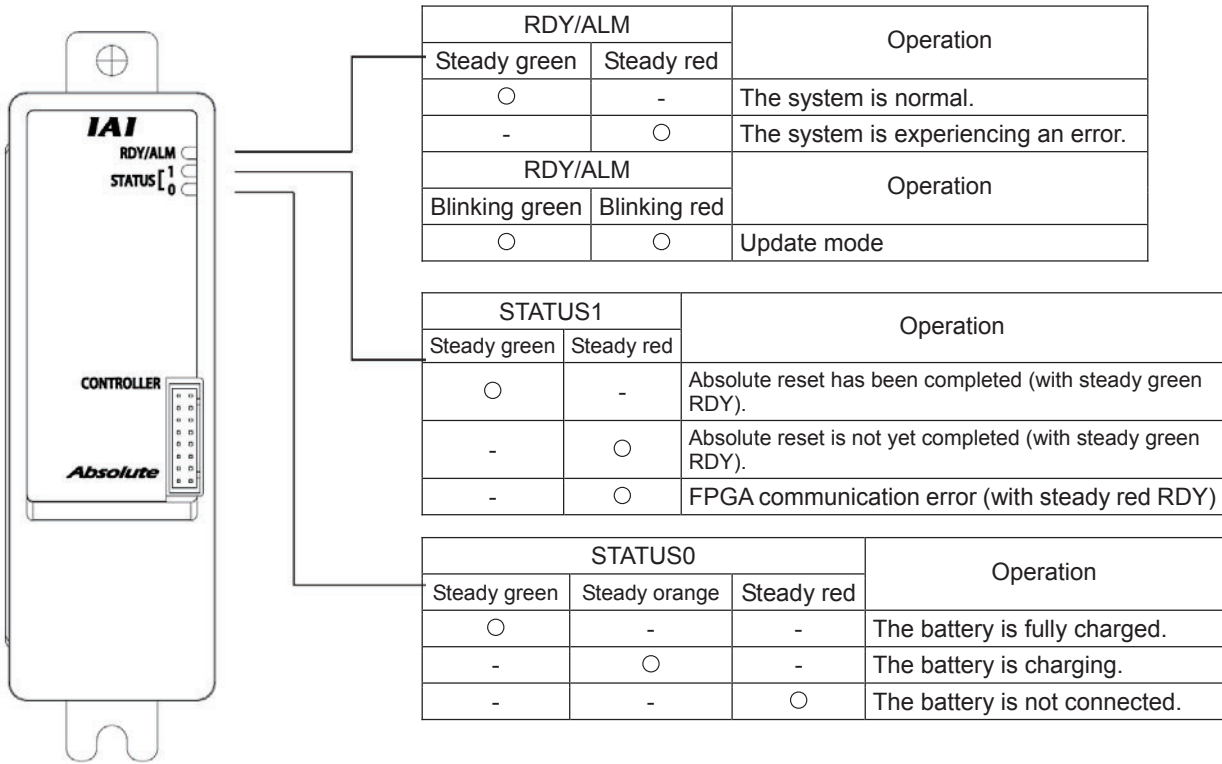

### [2] Setting switches

These switches are used to set the speed and turn on/off the update mode.

(The switches are designated as 1, 2, 3 and 4 from the top.)

The switch settings, other than the update mode selector switch, are read and take effect when the controller power is turned off.

The update mode selector switch becomes enabled after the controller power is turned off, and the battery is removed and switched.

Switch	Function
1	Speed setting switch 1
2	Speed setting switch 2
3	Update mode selector switch (Keep this switch in the OFF position.)
4	Model selector switch (Keep this switch in the ON position.)

#### [Settings of speed selector switches]

Setting Switch		Encoder Max. Rotation Speed [rpm]		Battery Retention Time (reference)
1	2	When the connected actuator is a model other than RCA2-***N;	When the connected actuator is RCA2-***N;	
OFF	OFF	100	75	20 days
ON	OFF	200	150	15 days
OFF	ON	400	300	10 days (Default setting)
ON	ON	800	600	5 days

Note 1) The backup time is a reference value assuming that the supplied battery is used at normal temperature without coordinate changes.

Note 2) If the motor is operated at a speed exceeding the specified speed while the controller power is turned off, absolute data will be lost.

[Update mode selector switches]

Switch	Function
3	
ON	Update mode
OFF	Normal mode

[Model selector switches]

Switch	Function
4	
ON	Set this to ON (Default setting)
OFF	-

- [3] Backup battery connector  
This connector is used to connect the absolute-data backup battery.
- [4] Ni-MH battery  
The absolute-data backup battery is stored here.
- [5] Power-supply terminal block  
The main power (24-VDC) input terminals of this unit are provided.

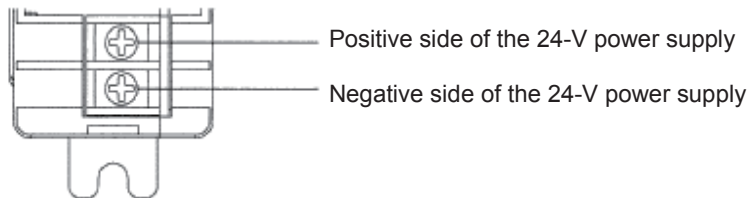

Note) Connect the simple absolute unit to the same power ground used by the controller to which the unit is connected.

- [6] RCP2/RCP3 connector  
This connector is used to connect the PG cable of a RCP2/RCP3 actuator.
- [7] RCA/RCA2 connector  
This connector is used to connect the PG cable of a RCA/RCA2 actuator.
- [8] Host controller connector  
This connector is used to send encoder feedback signals to the host controller.  
Note) Take note that the cable is different depending on the controller to which the unit is connected.
  - PCON/PSEL: CB-PC-\*\*\*
  - ACON:        CB-AC-\*\*\*       \*\*\* indicates the cable length. Example) 002: 20 cm

## 2.3 External Dimensions

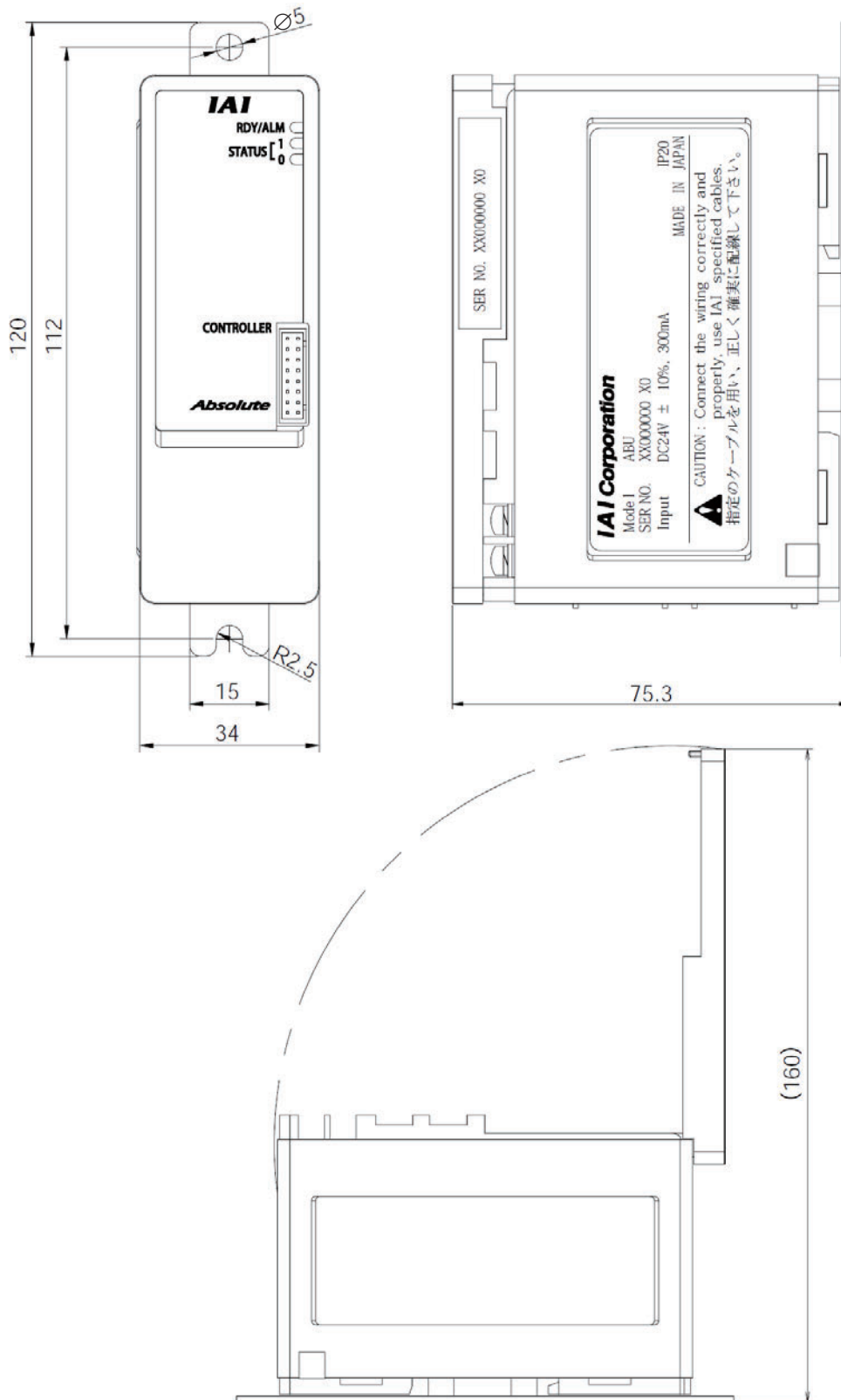

### 3. Installation and Noise Elimination

Pay due attention to the environment in which the controller is installed.

#### 3.1 Installation Environment

The controller can be used in a pollution degree 2\*<sup>1</sup> or equivalent environment.

\*1 Pollution degree 2: Normally, only non-conductive pollution occurs. However, a temporarily electricity conductive pollution caused by condensation may be expected (EN60947-5-1).

- (1) When installing and wiring the controller, do not block the cooling vent holes. (If sufficient ventilation is not provided, not only the controller is unable to demonstrate its designed performance, but it may also cause unexpected breakdown.)
- (2) Prevent foreign objects from entering the controller through vent holes. The controller is not constructed dustproof or waterproof (oilproof). Accordingly, avoid using the controller in a dusty place or place subject to oil mist or cutting fluid.
- (3) Do not expose the controller to direct sunlight or irradiated heat from heat treatment ovens or other large heat sources.
- (4) Use the controller in an environment of 0 to 40°C in surrounding air temperature and 85% or below (non-condensing) in humidity, free from corrosive or natural gases.
- (5) Use the controller in an environment where it will not be subject to external vibration or shock.
- (6) Prevent entry of electrical noise into the controller or its cables.

#### 3.2 Supplied Power

The supplied power is 24 VDC  $\pm$  10%.  
(Maximum power-supply current: 300 mA)

#### 3.3 Noise Elimination and Grounding

This section explains how to eliminate noise in the controller during use.

##### (1) Wiring and power supply

- [1] Provide dedicated class D grounding. The grounding wire should have a wire size of 1.6 mm<sup>2</sup> or larger.

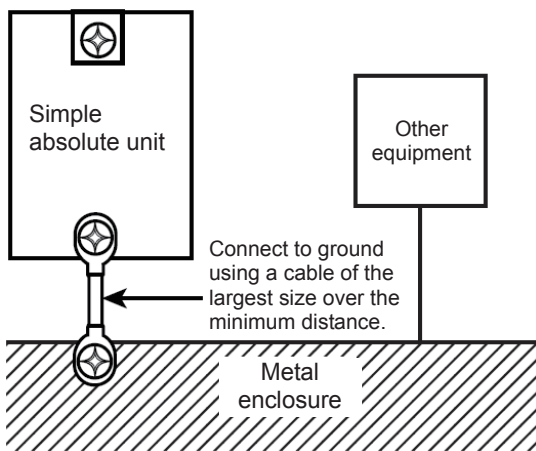

Class D grounding  
(Formerly class 3 grounding: Grounding resistance of 100  $\Omega$  or less)

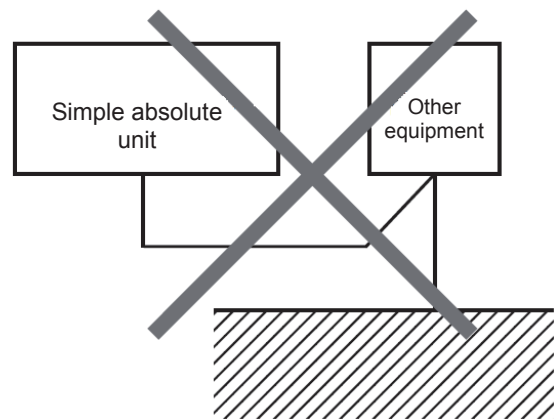

Connect the grounding wire to one controller at a time without sharing it with or connecting via other devices.

## [2] Wiring precautions

Use a twisted cable for connecting the 24-VDC power supply.

Wire the controller cables separately from high-current lines of power circuits, etc. (Do not bundle them together or place them in the same cable duct.)

## (2) Noise sources and how to prevent noise

There are many noise sources, but the ones you should pay greatest attention to are solenoid valves, magnet switches and relays. Noise from these parts can be prevented by the methods specified below.

### [1] AC solenoid valves, magnet switches and relays

Action --- Install a surge absorber in parallel with the coil.

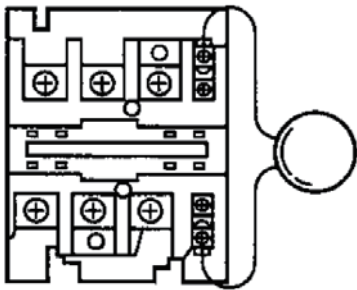

Surge absorber

← Install the surge absorber at the closest possible location to the coil.

If the surge absorber is installed on a terminal block or otherwise away from the coil, the surge absorber cannot eliminate noise effectively.

### [2] DC solenoid valves, magnet switches and relays

Action --- Install a diode in parallel with the coil, or use the built-in diode.

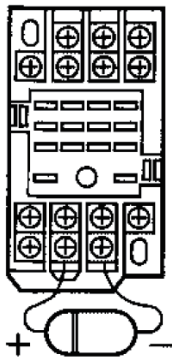

With DC circuits, connecting the diode in wrong polarities may damage the diode, internal controller parts, and/or DC power supply. Pay careful attention to the diode polarities.

## 3.4 Heat Dissipation and Installation

Design the control panel size, controller layout and cooling method so that the surrounding air temperature around the controller will be kept to 40°C or below.

Mount the controller vertically on a wall, as shown below. Since the controller is cooled by natural convection, be sure to heed this orientation and provide sufficient clearances on top and bottom to make sure sufficient air will flow around the controller.

If multiple controllers are installed side by side, provide an agitation fan at the top of the controllers. Also provide a minimum clearance of 80 mm between the front panel of the controller and the wall (lid).

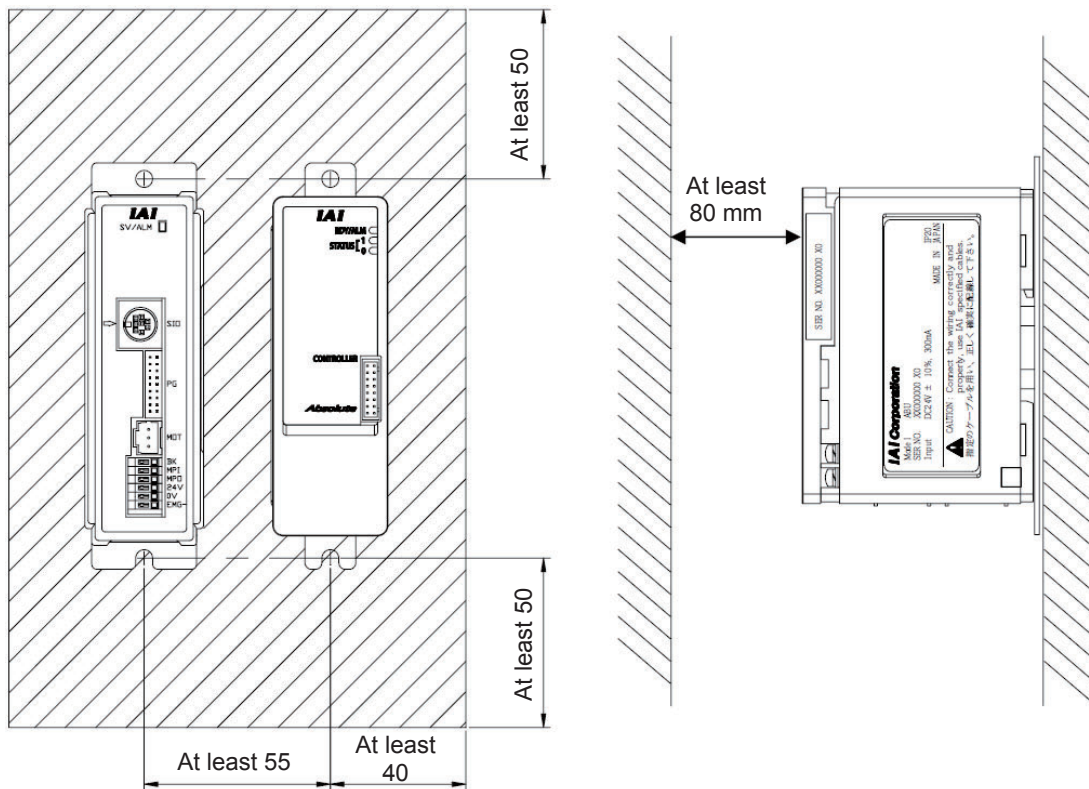

## 4. Wiring

### 4.1 Configuration

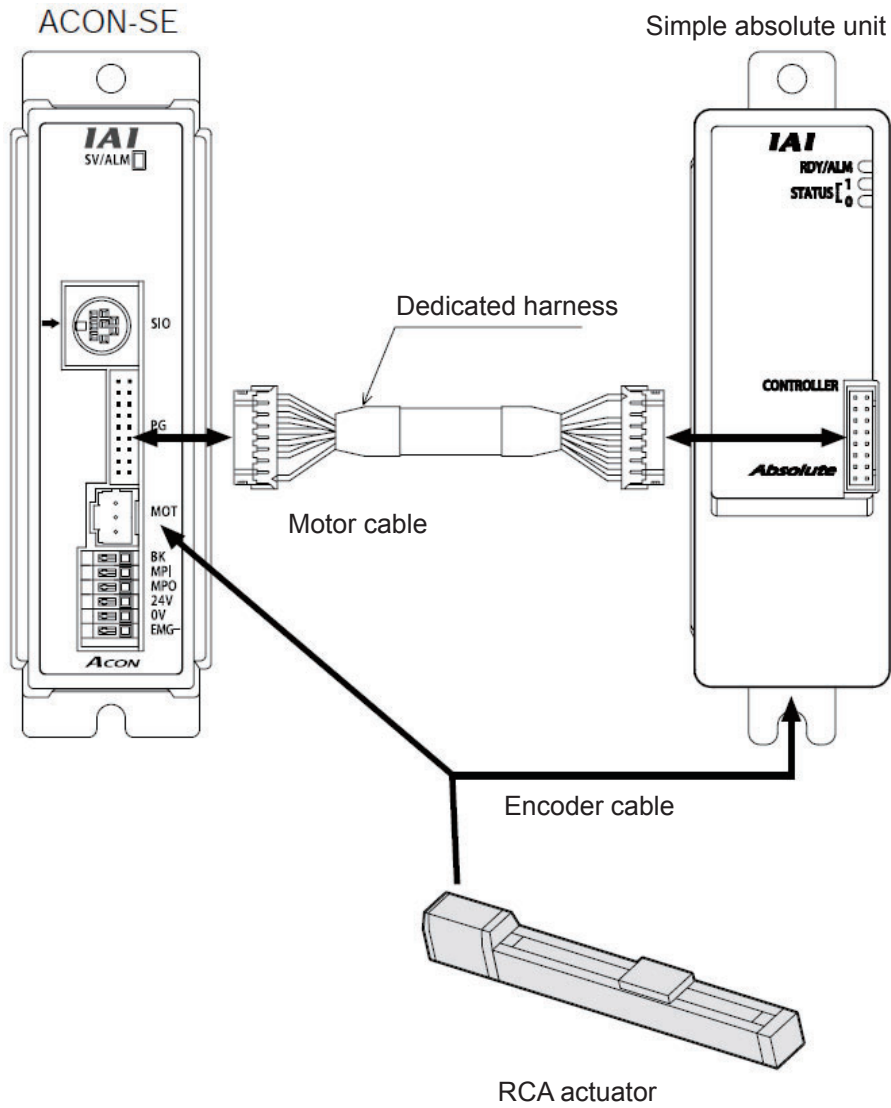

**Caution:** When connecting the dedicated harness to the simple absolute unit, connect it to the correct connector. There are two connectors on the simple absolute unit, one for RCA and the other for RCP2.

## 4.2 Connecting the Dedicated Cable

Connect the dedicated harness to the PG connector on the controller and the CONTROLLER connector on the simple absolute unit.

\* Make sure the connectors at the ends of the cable are oriented correctly.

### 4.2.1 PCON/PSEL Controller Cable

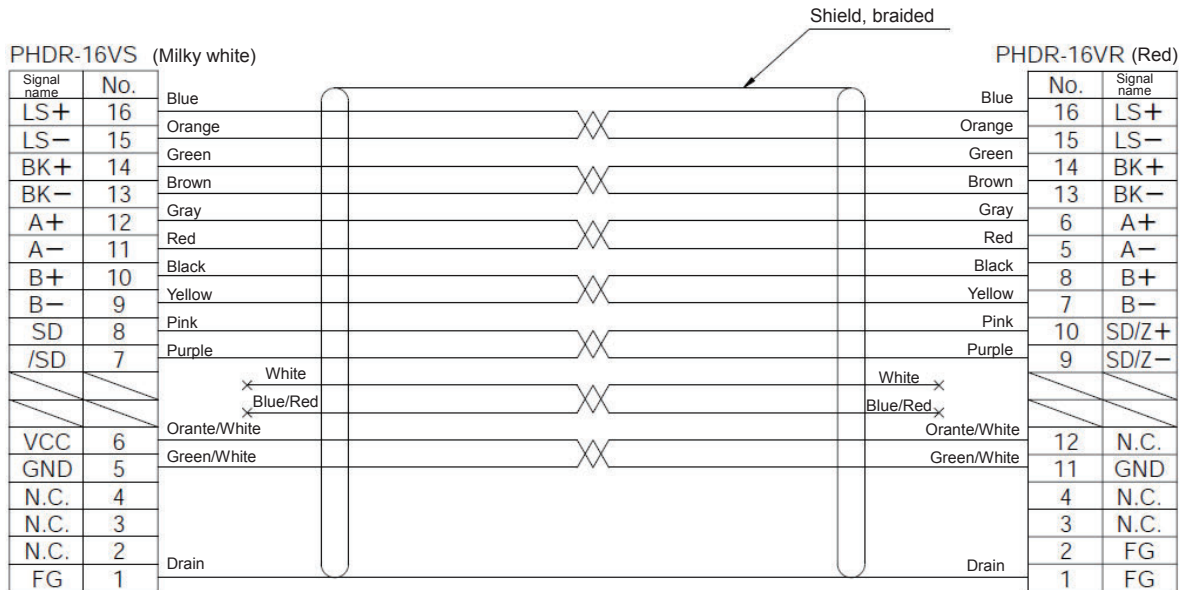
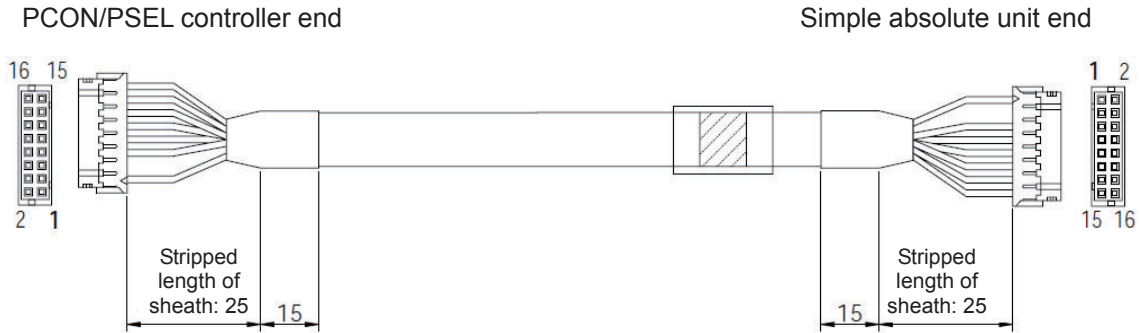

## 4.2.2 ACON Controller Cable

\* Make sure the connectors at the ends of the cable are oriented correctly.

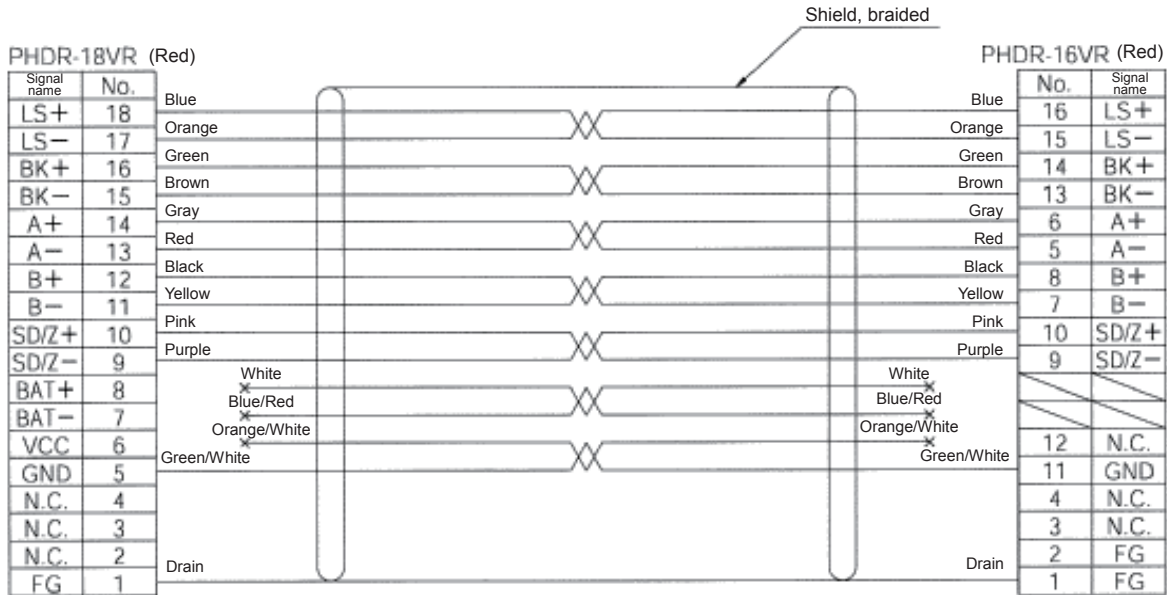
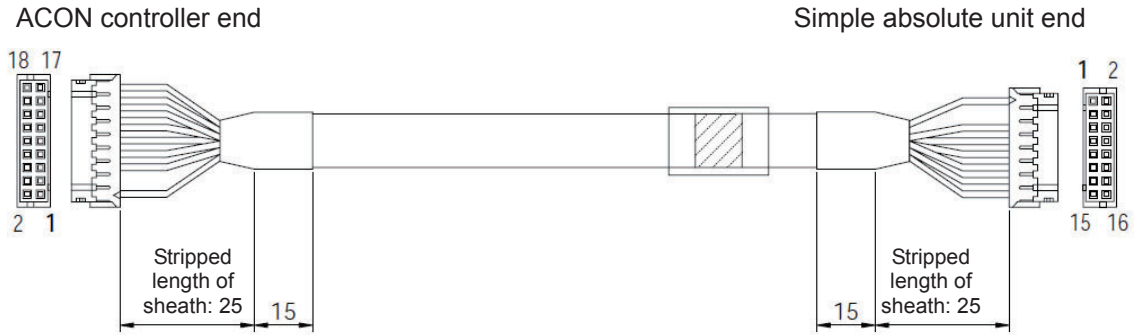

## 4.3 How to Open the Lid of the Simple Absolute Unit

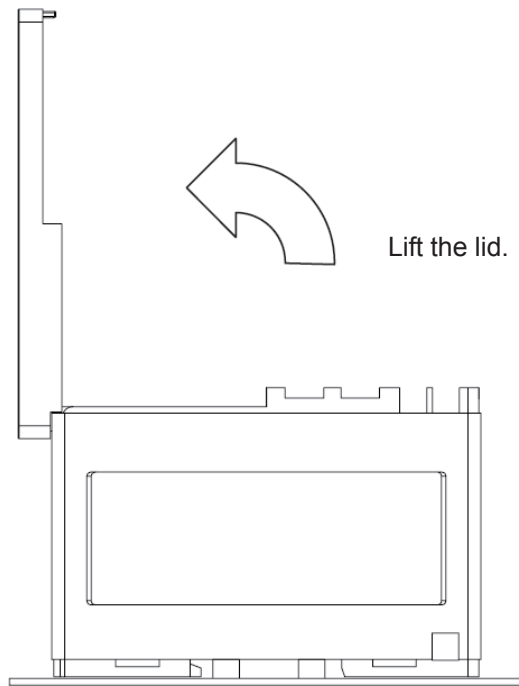

Lid closed

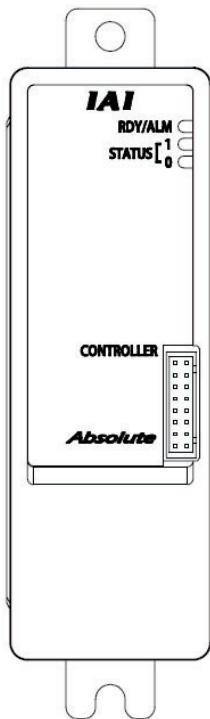

Lid open



## 4.4 Wiring the Power Supply

- Wiring the Power Supply

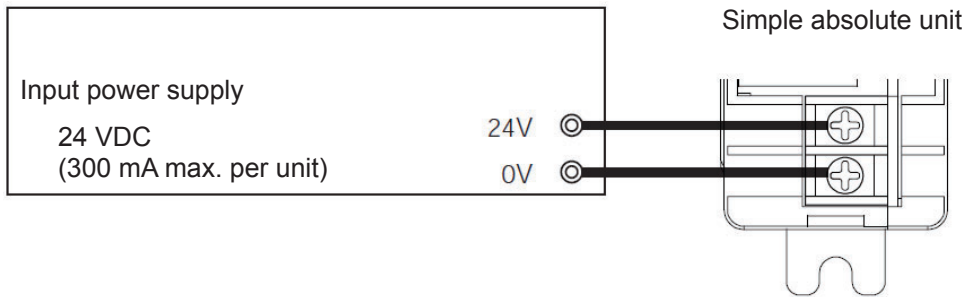

Use a power cable satisfying the following specifications.

Item	Specification
Applicable wire	Single wire: $\varnothing 1.0$ / Stranded: $0.8 \text{ mm}^2$ / Size: AWG 18 (copper wire)
Terminal	M3 round terminal of 6 mm or narrower
Temperature rating of isolation cover	$60^\circ\text{C}$ or above

Note) Take note of the following points when providing a separate power supply for the simple absolute unit and ACON · PCON · PSEL controller, respectively:

- (1) Connect the simple absolute unit to the same power ground used by the controller to which the unit is connected.
- (2) Power up the simple absolute unit before the controller. (The two may be powered up simultaneously.)  
If the controller power is turned on first, the controller will not be able to recognize the simple absolute unit and an encoder receive error (ACON, PCON: 0E5, PSEL: 619) may generate.
- (3) When shutting down the power, shut down both the simple absolute unit and the controller at the same time, or the controller first. If the simple absolute unit is shut down first, a “disconnecting error” will be recorded on the controller alarm list.

## 5. Operation

### 5.1 Startup Procedure

#### 5.1.1 Piano Switch Settings

These switches are used to set the rotation speed setting and to turn on/off the update mode. (The switches are designated as 1, 2, 3 and 4 from the top.)

The switch settings, other than the update mode selector switch, are read and reflected when the controller power is turned off.

The update mode selector switch becomes enabled after the controller power is turned off, and the battery is removed and switched.

(Refer to 2.2.1, “Names” for the location of piano switches.)

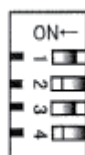

Switch	Function
1	Speed setting switch 1
2	Speed setting switch 2
3	Update mode selector switch (Keep this switch in the OFF position.)
4	Model selector switch (Keep this switch in the ON position)

[Settings of speed selector switches]

If the motor is operated at a speed exceeding the specified speed while the controller power is turned off, absolute data will be lost. The motor speed can be set to one of four levels. The lower the motor speed, the longer the backup time will become.

Setting Switch		Encoder Max. Rotation Speed [rpm]		Battery Retention Time (reference)
1	2	When the connected actuator is a model other than RCA2-***N;	When the connected actuator is RCA2-***N;	
OFF	OFF	100	75	20 days
ON	OFF	200	150	15 days
OFF	ON	400	300	10 days (Default setting)
ON	ON	800	600	5 days

Note 1) The backup time is a reference value assuming that the unused battery is used at normal temperature without coordinate changes.

Note 2) The default settings are “OFF” for switch 1 and “ON” for switch 2, which sets the motor speed to 400 rpm.

[Update mode selector switches]

Switch	Function
3	
ON	Update mode
OFF	Normal mode (Default setting)

[Model selector switches]

Switch	Function
4	
ON	Set this to ON. (Default setting)
OFF	-

In the update mode, the RDY/ALM LED blinks in green/red.



## Caution About Battery Charge and Discharge

Please have the battery charged for more than 72 hours before using for the first time or after replacing with a new one.

The battery gets charged while the controller is supplied with 24V power.

It is possible to retain the encoder data for the duration shown below for each hour of battery charge.

Leaving the controller power off for more than the data holding time will lead to a loss of the data. Have the battery charged as early as possible.

There is life to the battery and the duration for data holding will decrease. Replace the battery if you confirm an extreme drop in data holding time even with enough charge time.

(Note) Data Holding Time \*Followings are the reference values of time assuming the battery is new.

Setting of encoder maximum rotation speed	100 (75)	200 (150)	400 (300)	800 (600)
Data holding time per hour of battery charge time (reference)	6.6H	5.0H	3.3H	1.6H
Holding time when fully charged (reference)	20 days	15 days	10 days	5 days

(Example) From Monday to Friday: charge for 8 hours per day, discharge for 16 hours,  
Saturday and Sunday: use with discharge

- If 800 [RPM] setting;

Full charge amount : 24 [h] × 5 [day] = 120 [h]

Total charge amount : 8 [h] × 1.6 [h] × 5 [day] = 64 [h]

Total discharge amount : 16 [h] × 5 [day] + 48 [h] = 128 [h]

→ It is necessary to have a full charge in 10-day pitch if starting on Monday.

- If 400 [RPM] setting;

Total charge amount : 8 [h] × 3.3 [h] × 5 [day] = 132 [h]

Total discharge amount : 16 [h] × 5 [day] + 48 [h] = 128 [h]

→ It is not necessary to have a continuous full charge if starting on Monday.

4-hour charge is stored every week.

\* The upper limit of power storage is a reference value for holding time after continuous battery charge.

## 5.1.2 Parameter Setting (High-Order Controller)

If the simple absolute unit is purchased separately and connected to an existing controller, one user parameter must be set. (If the simple absolute unit was ordered together with the controller, this parameter is set at the factory prior to the shipment.)

\* You need the PC software or teaching pendant to set user parameters.

### (1) ACON or PCON

Changes to be made

User parameter No. 83 Specify ABS unit: '1' (Used)

### (2) PSEL

Changes to be made

• Axis-specific parameter No. 38 "By encoder ABS/INC type": Specify '1' (ABS).

• Axis-specific parameter No. 46 "ABS unit usage selection": Specify '1' (Used).

## 5.2 How to Perform an Absolute Reset

### 5.2.1 Absolute Reset Using PIO Signals

- ACON or PCON

\* Refer to the operation manual for your controller for details on input signals.

(1) Supply the main power (24 VDC) to the controller and simple absolute unit.

(2) An absolute encoder error (2) alarm is output.

(3) Input a PIO alarm reset signal.

(4) Turn ON the PIO pause input.

Note) When a pause signal input is provided in the selected PIO pattern.

(5) Input a PIO servo ON signal.

Note) When a servo ON signal input is provided in the selected PIO pattern.

The SV lamp on the controller should illuminate in green.

(6) Input a PIO home return signal.

When the home return is completed, the SV lamp on the controller should illuminate in green.

(7) An absolute reset is executed upon completion of the home return (HEND ON).

\* Alarm reset, servo ON and home return can also be performed from the teaching pendant or PC software.

(Note 1) If the simple absolute unit is connected to ACON, before an absolute reset is performed, an operation may be executed for a maximum of the lead length for magnetic phase detection.

(Note 2) When the controller is PSEL, perform an absolute reset using the PC software.

## 5.2.2 Absolute Reset from the PC Software

- ACON or PCON

- (1) Supply the main power (24 VDC) to the controller and simple absolute unit.
- (2) Bring the PC software online to communicate with the controller (connect the controller and PC using a dedicated communication cable).

Check for connected axes	
Axis No.	Status
0	Connected
1	Connected
2	
3	
4	
5	
6	
7	(Checking)

- (3) Select the MANU operation mode.  
Select teaching mode 1 or teaching mode 2.

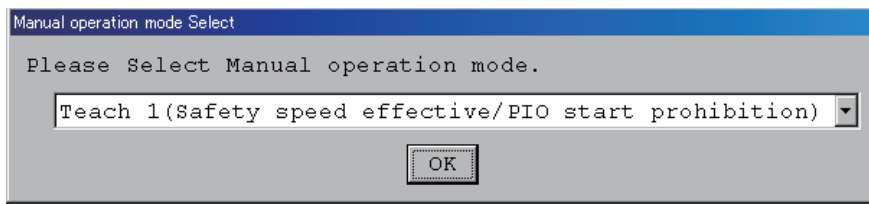

- (4) A "0EE: Absolute encoder error (2)" generates.

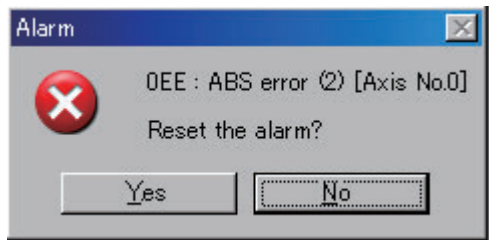

- (5) Select **Yes (Y)**.
- (6) Click **Position (T)**, select **Edit/Teach (E)** [1], select the applicable axis number [2], and then click **OK** [3].

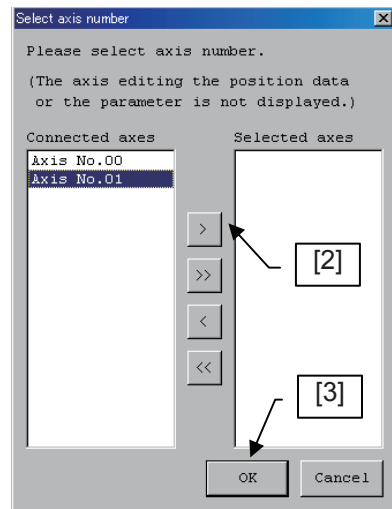
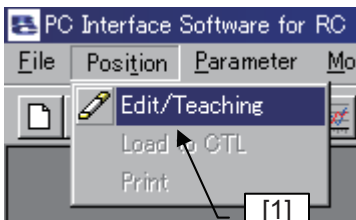

(7) Click **Servo**.

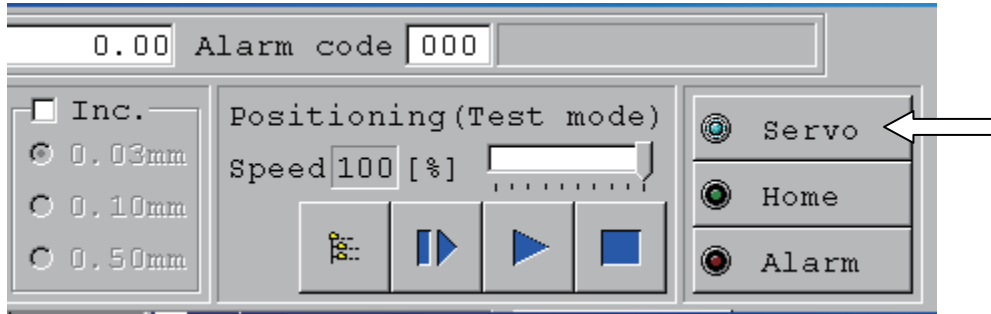

The servo lamp should illuminate in blue when **Servo** is clicked.

(8) Click **Home**.

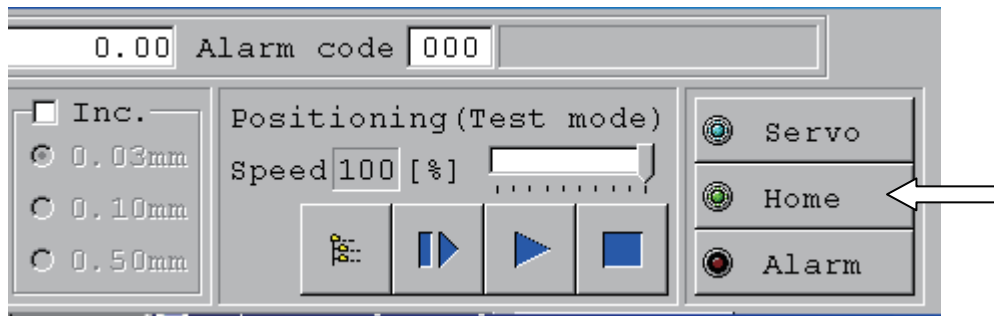

The home lamp should illuminate in blue when home return is completed.

An absolute reset has been executed.

### • PSEL

Perform an absolute reset based on the following procedure using "X-SEL PC Software (V7.04.00.00 ~)."

- (1) Supply the main power (24 VDC) to the controller and the simple absolute unit.  
If there is no item to be adjusted other than "ABS unit encoder error (2)" and the panel unit is connected, the 7-segment LED will display "E41C."
- (2) Bring the X-SEL PC software online to communicate with the controller (connect the controller and the PC using a dedicated communication cable).
- (3) When the [Confirm Connection] dialog box is displayed, adjust the communication port setting according to the PC in use. Click the [OK] button. (The baud rate is automatically recognized even if you do not specify it.)

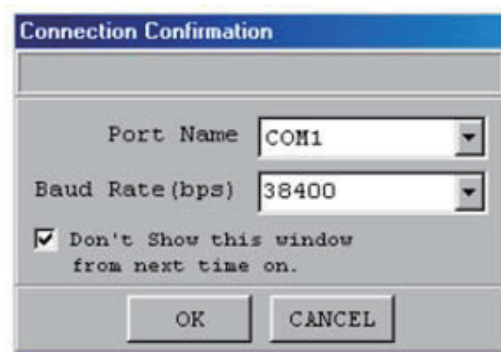

- (4) The X-SEL PC Software window is displayed. If an error is detected, the corresponding error message will be displayed. Click the [OK] button to close the error message. If the “ABS unit encoder error (2)” is detected, the following error message will be displayed.

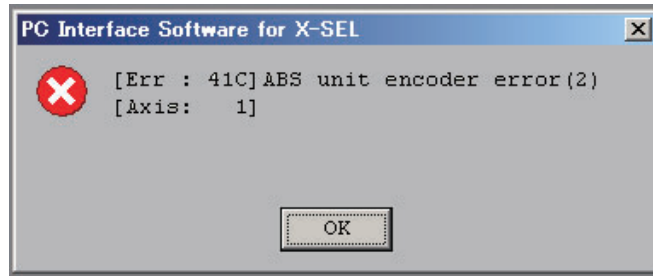

- (5) By selecting [Monitor (M)] and then [Error Details (E)] from the menu, the current error status can be checked. If the “ABS unit encoder error (2)” is detected, the status will be as follows (The example is when the simple absolute unit is used for the first axis). Once you check the status, close the [Error Details] window.

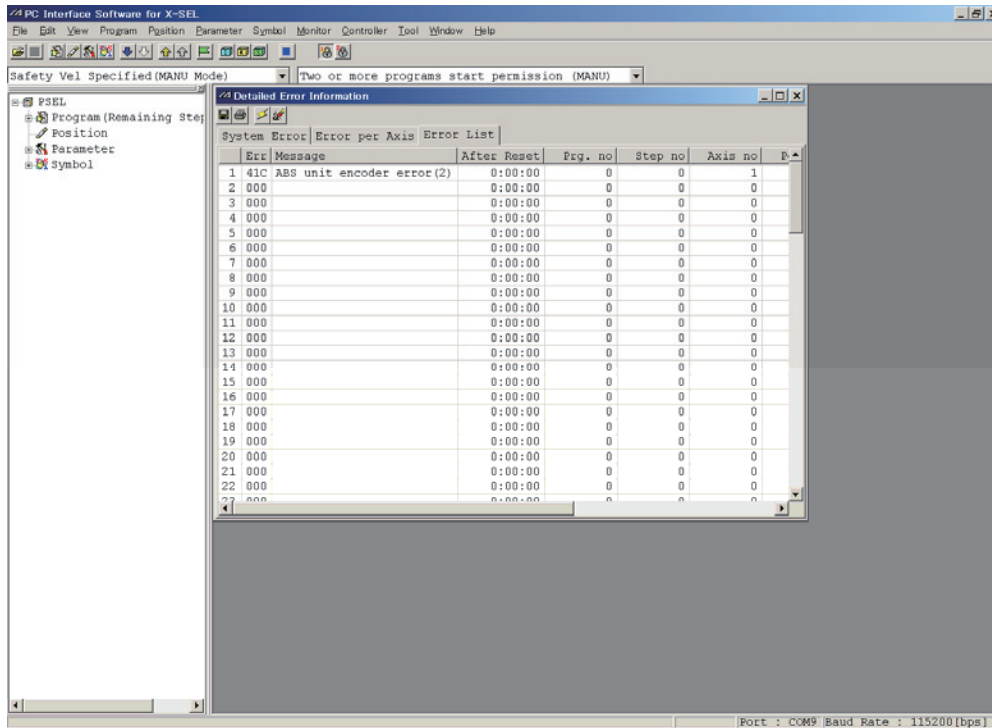

- (6) From the menu, select Controller (C) and then Absolute Reset (A).
- (7) When the [Warning] window is displayed, click the [OK] button.

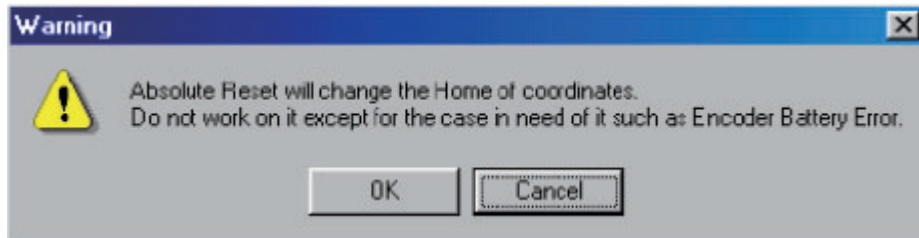

- (8) The [Absolute Reset] window will be displayed. Click [here](#) and select the axis for which an absolute reset is to be performed.

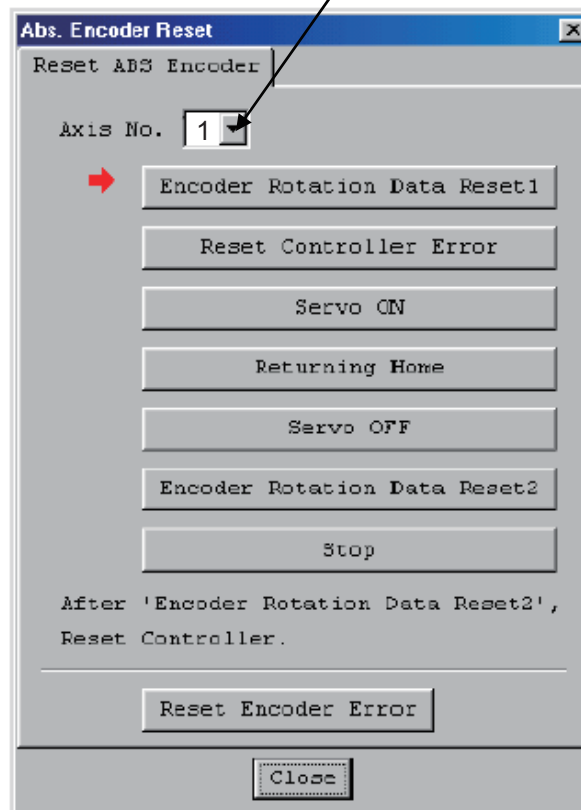

(9) Click the following process buttons in order. When one process is completed, the red arrow moves to the next.

- [1] Controller error reset
- [2] Servo OFF
- [3] Simple absolute unit status initialization
- [4] Excitation detection completion status clear
- [5] Servo ON
- [6] Home return
- [7] Absolute reset
- [8] Completion check of an absolute reset

Upon pressing the [Simple absolute unit status initialization] button, a warning dialog box is displayed, indicating that an absolute reset is to be started. Click the [Yes (Y)] button.

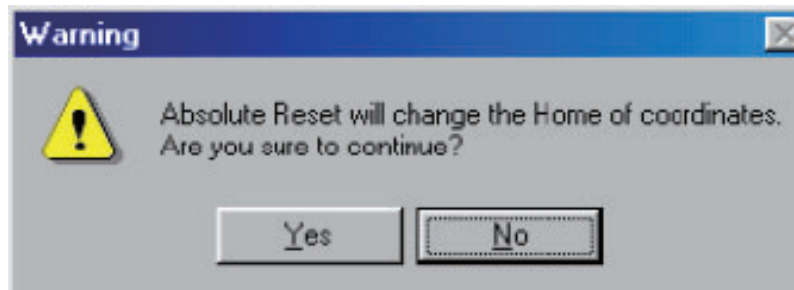

When the confirmation dialog box is displayed again, click the [Yes (Y)] button.

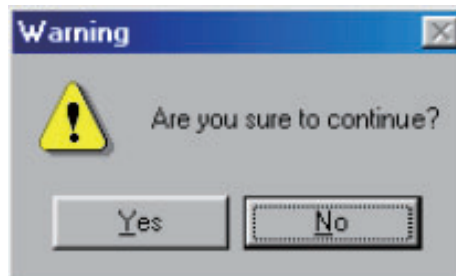

Upon completion of the [Completion check of an absolute reset] process, the red arrow returns to the position shown in (8). When performing an absolute reset of another axis, select the target axis, and perform the steps starting with (8). To end the operation, click the [Close] button to close the [Absolute Reset] window.

(Note) When performing an absolute reset for multiple axes, end steps (8) and (9) for all axes before performing a software reset described in step (10) below.

- (10) When the [Confirmation] dialog box is displayed for a software reset, click the [Yes (Y)] button and restart the controller.

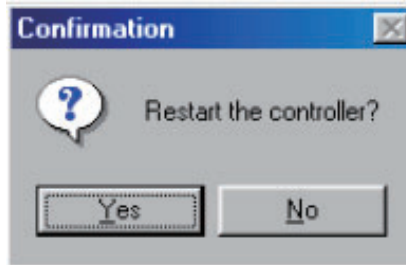

(Note) After an absolute reset is performed, be sure to perform a software reset.

- (11) If no error is generated after the controller is restarted, and the panel unit is connected, the 7-segment LED will display "rdy."  
(12) This completes the absolute reset operation.

## 5.2.3 Absolute Reset from the Teaching Pendant (Example: CON-T)

- ACON or PCON

- (1) Connect the teaching pendant to the controller and supply the main power (24 VDC).
- (2) When the teaching pendant is started, select TEACH1 or TEACH2.

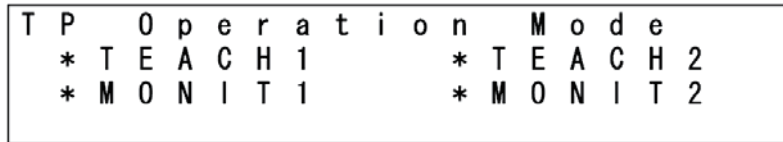

Select either the or key.

Teaching pendant operation mode selection screen

- (3) Select the error list on the mode selection screen. Upon confirming that an absolute encoder error is generated, reset the error.

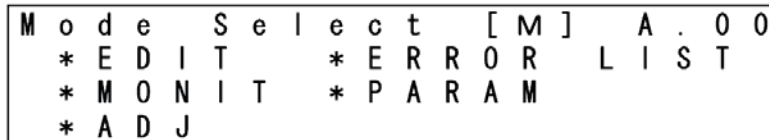

Press the key.

Mode selection screen

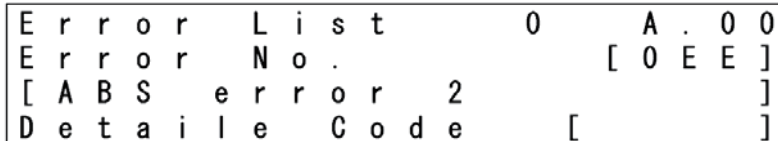

Confirm that error No. 0EE, an absolute encoder error, is generated, and press the key.

Error list screen

- (4) Press the key and return to the Mode selection screen, press the → → keys and then turn the servo on.

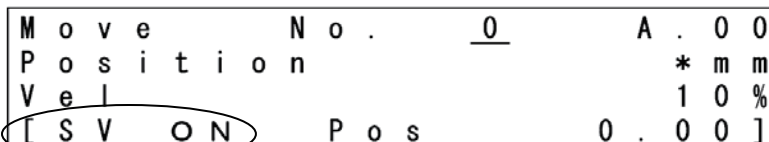

Confirm SV ON is displayed.

- (5) Press the key and perform a home return. When the home return is completed, the absolute reset will also be completed. Confirm that the LED, "STATUS1," on the front side of the simple absolute unit is lit green.

(Note 1) When the controller is PSEL, perform an absolute reset using the PC software.

## 5.3 Replacing the Battery

The battery life is three years, and the expiration guideline is printed on the side of the battery. Even if no battery error is generated, it is recommended that you replace the battery if it is passed the expiration date.

[Items to be prepared]

- Replacement battery: AB-7, Manufacturer: IAI

[Procedure]

- [1] Stop the axis operation and turn the power off.
- [2] Remove the wire that is connected to the front of the controller.

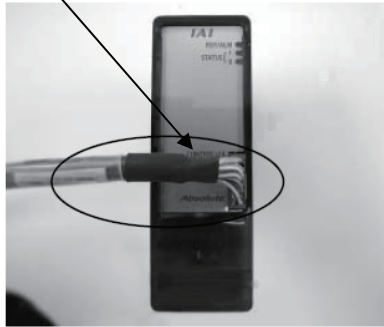

- [3] Open the lid and remove the battery connector.

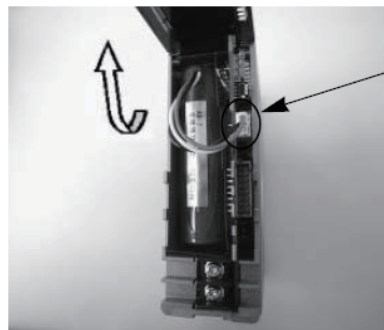

Battery connector

- [4] Pull out the battery from the main unit.

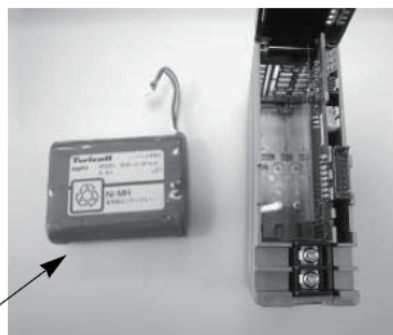

Removed battery

- [5] Attach the replacement battery and connect the battery connector.

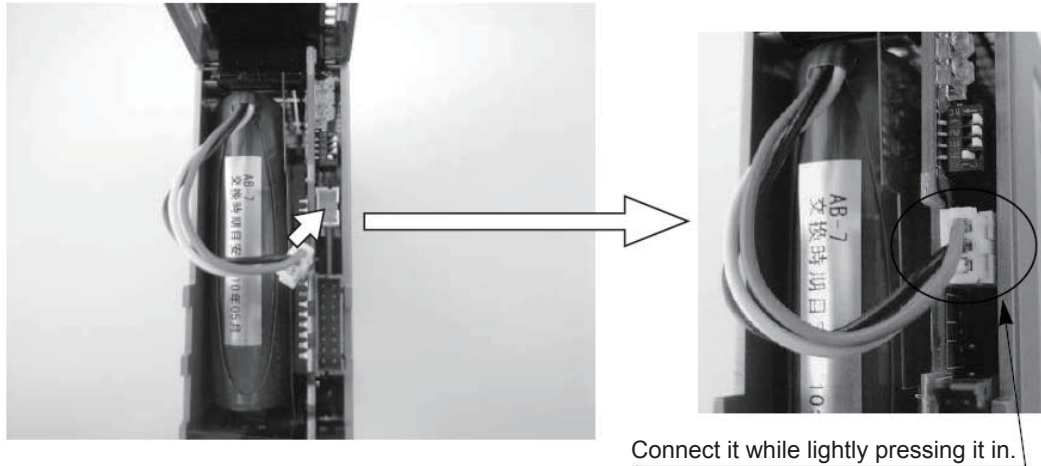

- [6] Close the lid and return the wire that was removed in step [1].  
[7] Turn the power on and perform an absolute reset described in Section 5.2.

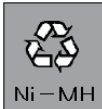

Instead of throwing it away, please place a used battery into a recycle box at a collaborating store with a recycle symbol or a specific collection window. Cooperation from individuals will lead to recycling of natural resources.

## 6. Troubleshooting

### 6.1 What to Do When a Problem Occurs

If a problem occurred, follow the steps below to facilitate speedy recovery and prevent the same problem from occurring again:

- a1. Check the status indicator lamps on the ACON/PCON controller.
  - SV (steady green) --- The servo is on.
  - ALM (steady red) --- An alarm is present, or an emergency stop has been actuated or the motor drive source has been cut off.
- a2. Check the status indicator lamps on the PSEL controller main unit.
  - PWR (steady green) The power is properly turned on.
  - RDY (steady green) Ready status
  - ALM (steady orange) Alarm status
  - EMG (steady red) Emergency stop status
  - SV1 (steady green) The servo is ON for the first axis.
  - SV2 (steady green) The servo is ON for the second axis.
- b. Check if any alarm has been generated.

If an alarm is present, you can check the corresponding error code by connecting the PC software or teaching pendant.

Even after the controller has been reset, detailed error information can still be checked using the PC software or teaching pendant.
- c. Check the cables for poor contact, disconnection, or pinching.

Before checking electrical continuity, turn off the power (to prevent a runaway system) and disconnect the cables (to prevent a sneak current path).
- d. Investigate the events leading up to the problem and the operating condition when the problem occurred.
- e. Check the serial numbers of the controller and actuator.
- f. Check the controller firmware version.
- g. Analyze the error cause.
- h. Action

(Reference) How the indicator lamps on the simple absolute unit change in each condition

RDY/ALM		Operation
Steady green	Steady red	
○	-	The system is normal.
-	○	The system is experiencing an error.

RDY/ALM		Operation
Blinking green	Blinking red	
○	○	Update mode (Note)

STATUS1		Operation
Steady green	Steady red	
○	-	Absolute reset has been completed (with steady green RDY).
-	○	Absolute reset is not yet completed (with steady green RDY).
-	○	FPGA communication error (with steady red RDY)

STATUS0			Operation
Steady green	Steady orange	Steady red	
○	-	-	The battery is fully charged.
-	○	-	The battery is charging.
-	-	○	The battery is not connected.

(Note) The unit is in the update mode. Disconnect the battery and set piano switch 3 to the OFF position. For more information on how to set the piano switches, refer to 5.1.1, "Piano Switch Settings."

## 6.2 Alarm Classification by Level

Alarms are classified into two levels according to the associated symptoms.

Alarm level	ALM lamp	*ALM signal	What happens when the alarm occurs	How to reset
Operation cancellation	Lit	Output	The actuator decelerates to a stop. The servo turns off.	Input an alarm reset signal (RES) from the PLC. Perform a reset from the PC/teaching pendant.
Cold start	Lit	Output	The actuator decelerates to a stop. The servo turns off.	Reconnect the power.

(Note) \* The ALM output signal is a negative logic signal.

After the power is input, the signal remains ON in normal condition and will turn OFF when an alarm occurs.

Although this signal will turn OFF when the power is cut off, it cannot be used as a contact-b interlock signal.

### ■ How to reset alarms of operation-cancellation level

Input an alarm reset signal (RES) for at least 6 msec.

The \*ALM signal turns ON. Turn the RES signal OFF after confirming that \*ALM is ON.

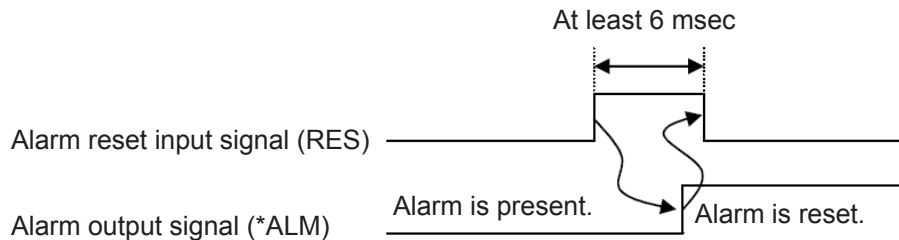

**Caution:** Reset each alarm after identifying and removing the cause.

If the cause cannot be removed, or when the alarm cannot be reset after removing the cause, contact IAI.

If the same error occurs again after resetting the alarm, it means that the cause of the alarm has not been removed.

### 6.3 Alarms, Causes and Actions

(1) Alarms relating to the simple absolute unit (ACON, PCON)

Code	Error	Cause/action	Alarm reset
0B6	Phase-Z detection timeout	<p>Cause:</p> <p>Phase Z could not be detected within the phase-Z output period of the simple absolute unit.</p> <p>[1] When the detail code is "H'0001" Pole sensing + magnetic pole check</p> <p>[2] When the detail code is "H'0002" Operation after reversing, following home return and push-motion operation</p> <p>Action:</p> <ul style="list-style-type: none"> <li>• Check the wiring condition of the motor relay cable.</li> <li>• Check the wiring condition of brake cable, and turn on/off the brake reset switch to see if "click" sound is heard.</li> <li>• Check if the mechanical parts are properly assembled.</li> <li>• Move the actuator away from the mechanical end and reconnect the power.</li> <li>• If the load is normal, turn off the power and try moving it manually to check the slide resistance.</li> </ul>	○ Operation-cancellation level
0E5	Encoder receive error	<p>Cause:</p> <p>[1] The controller is powered up before the simple absolute unit when the 24-V power supply is turned on.</p> <p>[2] When the detail code is "H'0001" The simple absolute unit cannot communicate properly due to noise, etc.</p> <p>[3] When the detail code is "H'0002" The controller cannot communicate properly with the simple absolute unit because the communication line in the encoder cable is disconnected.</p> <p>Action:</p> <p>[1] Make sure the simple absolute unit is powered up before (or simultaneously with) the controller.</p> <p>[2] Change the installation location of the controller. Implement noise measures such as installing a FG, noise filter, clamp filter, etc.</p> <p>[3] Check the connectors on the encoder relay cable between the controller and simple absolute unit for looseness. Or, replace the cable.</p>	X Cold-start level
0E8	Phase A/B open detection	Encoder signals cannot be detected properly.	X Cold-start level
0E9	Phase A open detection	<p>Cause:</p> <p>[1] The connectors on the encoder relay cable are loose or disconnected.</p> <p>[2] Piano switch 4 is set wrongly.</p>	
0EA	Phase B open detection	<p>Action:</p> <p>[1] Check the connectors for looseness and disconnection.</p> <p>[2] Check the switch setting by referring to 5.1.1, "Piano Switch Settings."</p>	

Code	Error	Cause/action	Alarm reset
		[3] Check the model number of the encoder cable. (Simple absolute unit ↔ Actuator) Note) RCP2 series only	
0ED	Absolute encoder error (1)	<p>Cause:</p> <p>[1] When the power was reconnected with the simple absolute unit communicating with the controller following an absolute reset, the current position changed due to an external factor, etc.</p> <p>[2] When an absolute reset was performed with the simple absolute unit communicating with the controller, the current position changed due to an external factor, etc.</p> <p>Action:</p> <p>[1] When the detail code is “H’0001” Turn off the power and make sure the actuator is not receiving vibration, etc., and then turn on the power again.</p> <p>[2] When the detail code is “H’0002” Make sure the actuator is not receiving vibration, etc., and then perform home return again.</p>	○ Operation-cancellation level
0EE	Absolute encoder error (2)	<p>Cause:</p> <p>[1] The power was turned on for the first time after the battery was connected.</p> <p>[2] When the detail code is “H’0001” The battery voltage dropped to a level at which the encoder counter data in the simple absolute unit could no longer be retained.</p> <p>[3] When the detail code is “H’0002” The encoder connector was removed during a power outage, or the encoder cable is disconnected.</p> <p>[4] When the detail code is “H’0003” A parameter was changed.</p> <p>[5] When the detail code is “H’0004” → The battery voltage dropped to 3.1 V.</p> <p>[6] When the detail code is “H’0005” → The battery is not connected.</p> <p>Action:</p> <p>If [1], [2] or [4] is the cause, perform an absolute reset by following the specified procedure (5.2, “How to Perform an Absolute Reset”).</p> <p>[2][5] Keep the power on for at least 48 hours to fully charge the battery, and then perform an absolute reset.</p> <p>* It takes 72 hours to fully charge the battery from when it is uncharged.</p> <p>[6] Check the battery connection.</p>	○ Operation-cancellation level
0EF	Absolute encoder error (3)	<p>Cause:</p> <p>While the power was cut off, the current value changed because the motor operated at a speed exceeding the specified speed due to an external factor, etc.</p> <p>Action:</p> <p>Change the applicable setting on the simple absolute unit and take measures to prevent the motor speed from rising above the specified speed while the power is cut off.</p> <p>If the backup time is sufficient, increase the motor speed setting.</p> <p>Reference: 5.1.1, “Piano Switch Settings”</p> <p>When this error occurs, perform an absolute reset by following the specified procedure (5.2, “How to Perform an Absolute Reset”).</p>	○ Operation-cancellation level

\* For other error codes, refer to the operation manual for the controller.

(2) Alarms relating to the simple absolute unit (PSEL)  
 (On the panel window, three digits after E become the error numbers.)

Error No.	Error	Contents/action, etc.	Alarm reset
41B	Absolute encoder error (1)	Cause: [1] The power was turned on again when an absolute reset was completed, or [2] When an absolute reset is performed, an axis movement was detected during a communication with the simple absolute unit due to an external factor. The actuator may have moved due to an external force, such as a reactive force of the self-supporting cable, or there may be vibration at the installation location. Action: [1] Turn off the power once, and turn it back on while making sure that there is no vibration on the actuator. (Error list Info. 1 is 1.) [2] Perform an absolute reset while making sure that there is no vibration on the actuator. (Error list Info. 1 is 2.)	○ Operation-cancellation level
41C	Absolute encoder error (2)	Cause: [1] The power was turned on for the first time after the battery was connected. [2] The battery voltage dropped to a level at which the encoder counter data in the simple absolute unit could no longer be retained. A parameter relating to home return may have been changed. (Error list Info. 1 is 1.) [3] The encoder connector was removed during a power outage, or the encoder cable was disconnected. (Error list Info. 1 is 2.) [4] The battery voltage dropped to 3.1 V. (Error list Info. 1 is 4.) [5] The battery is not connected. (Error list Info. 1 is 5.) Action: Perform an absolute reset by following the absolute reset procedure. When the battery voltage may have dropped as described in [2] or the cause is [4], keep the power on for at least 48 hours to fully charge the battery, and then perform an absolute reset. * It takes 72 hours to fully charge the battery from when it is uncharged.	○ Operation-cancellation level
41D	Absolute encoder error (3)	Cause: An axis movement was detected at a speed exceeding the setting value specified in the rotation speed setting of the simple absolute unit due to an external factor while the power was cut off. Action: Change the applicable setting on the simple absolute unit, or take measures to prevent the axis from moving above the specified speed while the power is cut off. If the backup time is sufficient, increase the rotation speed setting. When this error occurs, perform an absolute reset by following the absolute reset procedure.	○ Operation-cancellation level

Error No.	Error	Contents/action, etc.	Alarm reset
619	ABS unit encoder receiving error	<p>When the simple absolute unit encoder command is issued, the response could not be properly received.</p> <p>Cause:</p> <p>[1] The controller is powered up before the simple absolute unit when the 24-V power supply is turned on.</p> <p>[2] The simple absolute unit cannot communicate properly due to noise, etc. The controller cannot communicate properly with the simple absolute unit because the communication line in the encoder cable is disconnected.</p> <p>Action:</p> <p>[1] Make sure that the simple absolute unit is powered up before (or simultaneously with) the controller.</p> <p>[2] Change the installation location of the controller. Implement noise measures such as installing a FG, noise filter, clamp filter, etc. Check the connectors on the encoder relay cable between the controller and the simple absolute unit for looseness. Or, replace the cable.</p>	<p>X</p> <p>Cold-start level</p>
D12	Encoder disconnection error	<p>Encoder signals cannot be detected properly.</p> <p>Cause:</p> <p>[1] The connectors on the encoder relay cable are loose or disconnected.</p> <p>(When the simple absolute unit is used)</p> <p>[2] The piano switch 4 on the simple absolute unit is set incorrectly.</p> <p>[3] The encoder cable model number is incorrect. (Between the simple absolute unit and the actuator)</p> <p>Action:</p> <p>[1] Check the connectors for looseness and disconnection. The power needs to be turned on again.</p> <p>(When the simple absolute unit is used)</p> <p>[2] Check the piano switch setting on the simple absolute unit.</p> <p>[3] Check the model number of the encoder cable.</p>	<p>X</p> <p>Cold-start level</p>

## Change History

Revision Date	Description of Revision
2009.1	First edition  Second edition  Third edition <ul style="list-style-type: none"> <li>· P19: Changed the method to turn on the power to turning on the absolute unit before or simultaneously with the controller (Added the simultaneous method).</li> <li>· P25: Added the absolute reset method using the teaching pendant.</li> <li>· P26 and 27: Added the method to replace the battery.</li> <li>· Made corrections where necessary.</li> </ul>
2009.8	Forth edition <ul style="list-style-type: none"> <li>· P10, 16, 22, and 24 through 28: Added the method of PSEL absolute reset.</li> </ul>
2010.2	Fifth edition <ul style="list-style-type: none"> <li>· Caution: Added RCL to the list of actuators not supporting the absolute unit.</li> <li>· P9: Added a description in 2.2.2 Functions [2] Setting switches.</li> <li>· P20: Added a description in 5.1.1 Piano Switch Settings.</li> </ul>
2010.5	Sixth edition <ul style="list-style-type: none"> <li>· Added “Before Use” on the first page following the front cover.</li> <li>· Added “Safety Precautions” in the first section after the Table of Contents.</li> <li>· Inserted “The controller can be used in a pollution degree 2...” in the preamble of “3.1 Installation Environment.”</li> <li>· Added “Revision History” on the last page.</li> <li>· Updated the back cover (Changed the addresses of the head office and the sales office, and included the 24-hour support: Eight, etc.)</li> </ul>
2011.04	Seventh edition <ul style="list-style-type: none"> <li>· A page for CE Marking added</li> </ul> Eighth edition
2011.07	Ninth edition <ul style="list-style-type: none"> <li>· P5: Contents changed in 1.5 Warranty</li> <li>· P22: Information added regarding battery charge and discharge</li> </ul>
2011.11	Tenth edition <ul style="list-style-type: none"> <li>· P10, 21, 22: Upper limit of encoder rotation identified for each model</li> </ul>
2014.05	Eleventh edition <ul style="list-style-type: none"> <li>· P8: Battery supplier changed and nominal capacity added</li> </ul>





## ***IAI Corporation***

Head Office: 577-1 Obane Shimizu-KU Shizuoka City Shizuoka 424-0103, Japan  
TEL +81-54-364-5105 FAX +81-54-364-2589  
website: [www.iai-robot.co.jp/](http://www.iai-robot.co.jp/)

Technical Support available in USA, Europe and China

## ***IAI America, Inc.***

Head Office: 2690 W. 237th Street, Torrance, CA 90505  
TEL (310) 891-6015 FAX (310) 891-0815  
Chicago Office: 110 East State Parkway, Schaumburg, IL 60173  
TEL (847) 908-1400 FAX (847) 908-1399  
Atlanta Office: 1220 Kennestone Circle, Suite 108, Marietta, GA 30066  
TEL (678) 354-9470 FAX (678) 354-9471  
website: [www.intelligentactuator.com](http://www.intelligentactuator.com)

## ***IAI Industrieroboter GmbH***

Ober der Röth 4, D-65824 Schwalbach am Taunus, Germany  
TEL 06196-88950 FAX 06196-889524

## ***IAI (Shanghai) Co., Ltd.***

SHANGHAI JIAHUA BUSINESS CENTER A8-303, 808, Hongqiao Rd. Shanghai 200030, China  
TEL 021-6448-4753 FAX 021-6448-3992  
website: [www.iai-robot.com](http://www.iai-robot.com)

## ***IAI Robot (Thailand) Co., Ltd.***

825 PhairojKijja Tower 12th Floor, Bangna-Trad RD., Bangna, Bangkok 10260, Thailand  
TEL +66-2-361-4458 FAX +66-2-361-4456