

# PROFIBUS-DP

Operation Manual, Fifteenth Edition

<b>X-SEL</b>	<b>SSEL</b>
<b>RCS-C</b>	<b>TT</b>
<b>ASEL</b>	<b>E-Con</b>
<b>PSEL</b>	<b>SCON-C</b>
<b>MSEL</b>	

***IAI America, Inc.***



## Please Read Before Use

Thank you for purchasing our product.

This Operation Manual explains the handling methods, structure and maintenance of this product, among others, providing the information you need to know to use the product safely.

Before using the product, be sure to read this manual and fully understand the contents explained herein to ensure safe use of the product.

The DVD that comes with the product contains operation manuals for IAI products.

When using the product, refer to the necessary portions of the applicable operation manual by printing them out or displaying them on a PC.

After reading the Operation Manual, keep it in a convenient place so that whoever is handling this product can reference it quickly when necessary.

### [Important]

- This Operation Manual is original.
- The product cannot be operated in any way unless expressly specified in this Operation Manual. IAI shall assume no responsibility for the outcome of any operation not specified herein.
- Information contained in this Operation Manual is subject to change without notice for the purpose of product improvement.
- If you have any question or comment regarding the content of this manual, please contact the IAI sales office near you.
- Using or copying all or part of this Operation Manual without permission is prohibited.
- The company names, names of products and trademarks of each company shown in the sentences are registered trademarks.



Caution: The following functions are described in the separate operation manual.

	Title of operation manual/Overview	Control number
1	PROFIBUS-DP Operation Manual Refer to this operation manual if you are using an ACON, PCON or SCON-CA controller(s).	ME0258

## Table of Contents

Safety Guide .....	1
1. Overview .....	7
2. Specifications .....	8
2.1 Interface Specifications.....	8
3. X-SEL-J/K/P/Q/JX/KX/PX/QX .....	9
3.1 ProfiBus-DP Board Types and Installation Positions in the X-SEL .....	9
(1) Compact type (J type) .....	10
(2) General-purpose type (K type).....	11
(3) P/Q types.....	12
3.2 Setting a ProfiBus-DP Board (Slave Station).....	13
(1) Name of each part.....	13
(2) ProfiBus-DP communication connector interface specifications.....	14
(3) Bus termination settings <Set using the termination switch>.....	14
(4) Node address settings <Set by the address setting dials> .....	15
(5) Monitor LED indications .....	15
3.3 Setting X-SEL I/O Parameters (Assigning I/O Ports).....	16
3.3.1 Board Installation Positions (Slots) and I/O Parameters.....	16
(1) J/JX type (compact type).....	16
(2) K/KX type.....	17
(3) P/PX/Q/QX type.....	17
3.3.2 Factory-set Parameters (Default Settings).....	18
3.3.3 Automatically Assigning X-SEL I/Os .....	20
3.3.4 Setting Examples for J/JX/K/KX Type Controllers .....	20
3.3.5 Setting Examples for P/PX/Q/QX Type Controllers .....	26
3.3.6 X-SEL I/O Port Numbers.....	32
3.3.7 Correspondence of X-SEL I/O Port Numbers and PLC Addresses.....	33
4. XSEL-R(A)/S(A)/R(A)X/S(A)X/R(A)XD/S(A)XD.....	38
4.1 Model Numbers .....	38
4.2 PROFIBUS-DP Interface .....	39
(1) Name of each part .....	39
(2) Monitor LED indications .....	39
4.3 Parameter Settings .....	40
4.4 Setting example .....	44
(1) Example for when using only PROFIBUS .....	44
(2) Example for when using PROFIBUS and I/O Board 1 together .....	46
(3) Example for when using PROFIBUS and I/O Board 1 together .....	48

4.5	Standard I/O Ports of XSEL Controller.....	50
4.6	Troubleshooting .....	52
5.	MSEL .....	54
5.1	Model Numbers.....	54
5.2	PROFIBUS-DP Interface.....	55
5.3	Parameter Settings.....	56
5.4	Setting Example.....	59
	(1) Example for when using only PROFIBUS-DP.....	59
	(2) Example for when using PROFIBUS-DP and I/O Board 1 together .....	61
5.5	I/O Ports of the MSEL.....	63
5.6	Precautions .....	65
5.7	Troubleshooting.....	66
6.	Tabletop Robot TTA.....	68
6.1	Model Numbers.....	68
6.2	Interface Specifications.....	69
6.3	Parameter Settings.....	70
6.4	Setting Example.....	74
	(1) Example for when using only PROFIBUS-DP.....	74
	(2) Example for when using PROFIBUS-DP and I/O Board 1 together .....	76
	(3) Example for when using PROFIBUS-DP (I/O2 and I/O3) together .....	78
6.5	I/O Ports of the TTA.....	80
6.6	Precautions .....	82
6.7	Troubleshooting.....	83
7.	Tabletop Robot TT.....	85
7.1	Model Numbers.....	85
7.2	ProfiBus Board.....	86
	7.2.1 Name of each part .....	86
	7.2.2 ProfiBus-DP Communication Connector.....	87
	7.2.3 Termination switch (Bus termination settings).....	87
	7.2.4 Address Setting Dials (Node Address Settings) .....	88
	7.2.5 Monitor LED indications .....	88
7.3	I/O Parameter Settings (I/O Port Assignments).....	89
	(1) Board installation position (slot) and parameter numbers.....	89
	(2) Factory-set parameters for the TT type.....	90
	(3) Example of parameter settings for the tabletop robot TT.....	91
7.4	I/O Port Numbers for TT .....	93

8. RCS-C, E-Con and SCON.....	95
8.1 Model Numbers.....	95
(1) RCS-C.....	95
(2) E-Con.....	96
(3) SCON.....	96
8.2 Setting a ProfiBus-DP Board (Slave Station).....	97
(1) Name of each part.....	97
(2) ProfiBus-DP communication connector interface specifications.....	97
(3) Bus termination settings.....	98
(4) Node address settings.....	98
(5) Monitor LED indications.....	99
(6) Input/output (I/O) signal assignments.....	100
(7) Correspondence of RCS-C, E-Con and SCON I/O port numbers and PLC addresses.....	104
9. ASEL, PSEL, SSEL.....	108
9.1 Model Numbers.....	108
9.1.1 ASEL, PSEL.....	108
9.1.2 SSEL.....	109
9.2 ProfiBus Interface.....	110
(1) Name of each part.....	110
(2) Status LED indications.....	110
(3) ProfiBus-DP communication connector.....	112
9.3 I/O Parameter Settings.....	113
(1) Network type setting.....	113
(2) Node address.....	113
(3) I/O part assignments.....	113
(4) Network error monitor.....	113
9.4 I/O Port Numbers and ProfiBus-DP Address Assignments.....	115
(1) Basic example.....	115
(2) Positioner mode.....	116
10. Common Items and Others.....	120
10.1 Communication Cable.....	120
10.2 Useful Function When Adjusting an X-SEL Controller.....	120
10.3 GDS Files.....	120
Change History.....	121



## Safety Guide

“Safety Guide” has been written to use the machine safely and so prevent personal injury or property damage beforehand. Make sure to read it before the operation of this product.

### Safety Precautions for Our Products

The common safety precautions for the use of any of our robots in each operation.

No.	Operation Description	Description
1	Model Selection	<ul style="list-style-type: none"> <li>● This product has not been planned and designed for the application where high level of safety is required, so the guarantee of the protection of human life is impossible. Accordingly, do not use it in any of the following applications.               <ol style="list-style-type: none"> <li>1) Medical equipment used to maintain, control or otherwise affect human life or physical health.</li> <li>2) Mechanisms and machinery designed for the purpose of moving or transporting people (For vehicle, railway facility or air navigation facility)</li> <li>3) Important safety parts of machinery (Safety device, etc.)</li> </ol> </li> <li>● Do not use it in any of the following environments.               <ol style="list-style-type: none"> <li>1) Location where there is any inflammable gas, inflammable object or explosive</li> <li>2) Place with potential exposure to radiation</li> <li>3) Location with the ambient temperature or relative humidity exceeding the specification range</li> <li>4) Location where radiant heat is added from direct sunlight or other large heat source</li> <li>5) Location where condensation occurs due to abrupt temperature changes</li> <li>6) Location where there is any corrosive gas (sulfuric acid or hydrochloric acid)</li> <li>7) Location exposed to significant amount of dust, salt or iron powder</li> <li>8) Location subject to direct vibration or impact</li> </ol> </li> <li>● Do not use the product outside the specifications. Failure to do so may considerably shorten</li> </ul>

No.	Operation Description	Description
2	Transportation	<ul style="list-style-type: none"> <li>● When the work is carried out with 2 or more persons, make it clear who is to be the leader and who to be the follower(s) and communicate well with each other to ensure the safety of the workers.</li> <li>● Consider well so that it is not bumped against anything or dropped during the transportation.</li> <li>● Transport it using an appropriate transportation measure.</li> <li>● Do not step or sit on the package.</li> <li>● Do not put any heavy thing that can deform the package, on it.</li> <li>● When using a crane capable of 1t or more of weight, have an operator who has qualifications for crane operation and sling work.</li> <li>● When using a crane or equivalent equipments, make sure not to hang a load that weighs more than the equipment's capability limit.</li> <li>● Use a hook that is suitable for the load. Consider the safety factor of the hook in such factors as shear strength.</li> <li>● Do not get on the load that is hung on a crane.</li> <li>● Do not leave a load hung up with a crane.</li> <li>● Do not stand under the load that is hung up with a crane.</li> </ul>
3	Storage and Preservation	<ul style="list-style-type: none"> <li>● The storage and preservation environment conforms to the installation environment. However, especially give consideration to the prevention of condensation.</li> </ul>
4	Installation and Start	<p>(1) Installation of Robot Main Body and Controller, etc.</p> <ul style="list-style-type: none"> <li>● Make sure to securely hold and fix the product (including the work part). A fall, drop or abnormal motion of the product may cause a damage or injury.</li> <li>● Do not get on or put anything on the product. Failure to do so may cause an accidental fall, injury or damage to the product due to a drop of anything, malfunction of the product, performance degradation, or shortening of its life.</li> <li>● When using the product in any of the places specified below, provide a sufficient shield.               <ol style="list-style-type: none"> <li>1) Location where electric noise is generated</li> <li>2) Location where high electrical or magnetic field is present</li> <li>3) Location with the mains or power lines passing nearby</li> <li>4) Location where the product may come in contact with water, oil or chemical droplets</li> </ol> </li> </ul> <p>(2) Cable Wiring</p> <ul style="list-style-type: none"> <li>● Use our company's genuine cables for connecting between the actuator and controller, and for the teaching tool.</li> <li>● Do not scratch on the cable. Do not bend it forcibly. Do not pull it. Do not coil it around. Do not insert it. Do not put any heavy thing on it. Failure to do so may cause a fire, electric shock or malfunction due to leakage or continuity error.</li> <li>● Perform the wiring for the product, after turning OFF the power to the unit, so that there is no wiring error.</li> <li>● When the direct current power (+24V) is connected, take the great care of the directions of positive and negative poles. If the connection direction is not correct, it might cause a fire, product breakdown or malfunction.</li> <li>● Connect the cable connector securely so that there is no disconnection or looseness. Failure to do so may cause a fire, electric shock or malfunction of the product.</li> <li>● Never cut and/or reconnect the cables supplied with the product for the purpose of extending or shortening the cable length. Failure to do so may cause the product to malfunction or cause fire.</li> </ul>





No.	Operation Description	Description
4	Installation and Start	<p>(3) Grounding</p> <ul style="list-style-type: none"> <li>● Make sure to perform the grounding of type D (Former Type 3) for the controller. The grounding operation should be performed to prevent an electric shock or electrostatic charge, enhance the noise-resistance ability and control the unnecessary electromagnetic radiation.</li> </ul> <p>(4) Safety Measures</p> <ul style="list-style-type: none"> <li>● When the work is carried out with 2 or more persons, make it clear who is to be the leader and who to be the follower(s) and communicate well with each other to ensure the safety of the workers.</li> <li>● When the product is under operation or in the ready mode, take the safety measures (such as the installation of safety and protection fence) so that nobody can enter the area within the robot's movable range. When the robot under operation is touched, it may result in death or serious injury.</li> <li>● Make sure to install the emergency stop circuit so that the unit can be stopped immediately in an emergency during the unit operation.</li> <li>● Take the safety measure not to start up the unit only with the power turning ON. Failure to do so may start up the machine suddenly and cause an injury or damage to the product.</li> <li>● Take the safety measure not to start up the machine only with the emergency stop cancellation or recovery after the power failure. Failure to do so may result in an electric shock or injury due to unexpected power input.</li> <li>● When the installation or adjustment operation is to be performed, give clear warnings such as "Under Operation; Do not turn ON the power!" etc. Sudden power input may cause an electric shock or injury.</li> <li>● Take the measure so that the work part is not dropped in power failure or emergency stop.</li> <li>● Wear protection gloves, goggle or safety shoes, as necessary, to secure safety.</li> <li>● Do not insert a finger or object in the openings in the product. Failure to do so may cause an injury, electric shock, damage to the product or fire.</li> <li>● When releasing the brake on a vertically oriented actuator, exercise precaution not to pinch your hand or damage the work parts with the actuator dropped by gravity.</li> </ul>

No.	Operation Description	Description
5	Teaching	<ul style="list-style-type: none"> <li>● When the work is carried out with 2 or more persons, make it clear who is to be the leader and who to be the follower(s) and communicate well with each other to ensure the safety of the workers.</li> <li>● Perform the teaching operation from outside the safety protection fence, if possible. In the case that the operation is to be performed unavoidably inside the safety protection fence, prepare the “Stipulations for the Operation” and make sure that all the workers acknowledge and understand them well.</li> <li>● When the operation is to be performed inside the safety protection fence, the worker should have an emergency stop switch at hand with him so that the unit can be stopped any time in an emergency.</li> <li>● When the operation is to be performed inside the safety protection fence, in addition to the workers, arrange a watchman so that the machine can be stopped any time in an emergency. Also, keep watch on the operation so that any third person can not operate the switches carelessly.</li> <li>● Place a sign “Under Operation” at the position easy to see.</li> <li>● When releasing the brake on a vertically oriented actuator, exercise precaution not to pinch your hand or damage the work parts with the actuator dropped by gravity.</li> </ul> <p>* Safety protection Fence : In the case that there is no safety protection fence, the movable range should be indicated.</p>
6	Trial Operation	<ul style="list-style-type: none"> <li>● When the work is carried out with 2 or more persons, make it clear who is to be the leader and who to be the follower(s) and communicate well with each other to ensure the safety of the workers.</li> <li>● After the teaching or programming operation, perform the check operation one step by one step and then shift to the automatic operation.</li> <li>● When the check operation is to be performed inside the safety protection fence, perform the check operation using the previously specified work procedure like the teaching operation.</li> <li>● Make sure to perform the programmed operation check at the safety speed. Failure to do so may result in an accident due to unexpected motion caused by a program error, etc.</li> <li>● Do not touch the terminal block or any of the various setting switches in the power ON mode. Failure to do so may result in an electric shock or malfunction.</li> </ul>
7	Automatic Operation	<ul style="list-style-type: none"> <li>● Before the automatic operation is started up, make sure that there is nobody inside the safety protection fence.</li> <li>● Before the automatic operation is started up, make sure that all the related peripheral machines are ready for the automatic operation and there is no error indication.</li> <li>● Make sure to perform the startup operation for the automatic operation, out of the safety protection fence.</li> <li>● In the case that there is any abnormal heating, smoke, offensive smell, or abnormal noise in the product, immediately stop the machine and turn OFF the power switch. Failure to do so may result in a fire or damage to the product.</li> <li>● When a power failure occurs, turn OFF the power switch. Failure to do so may cause an injury or damage to the product, due to a sudden motion of the product in the recovery operation from the power failure.</li> </ul>

No.	Operation Description	Description
8	Maintenance and Inspection	<ul style="list-style-type: none"> <li>● When the work is carried out with 2 or more persons, make it clear who is to be the leader and who to be the follower(s) and communicate well with each other to ensure the safety of the workers.</li> <li>● Perform the work out of the safety protection fence, if possible. In the case that the operation is to be performed unavoidably inside the safety protection fence, prepare the “Stipulations for the Operation” and make sure that all the workers acknowledge and understand them well.</li> <li>● When the work is to be performed inside the safety protection fence, basically turn OFF the power switch.</li> <li>● When the operation is to be performed inside the safety protection fence, the worker should have an emergency stop switch at hand with him so that the unit can be stopped any time in an emergency.</li> <li>● When the operation is to be performed inside the safety protection fence, in addition to the workers, arrange a watchman so that the machine can be stopped any time in an emergency. Also, keep watch on the operation so that any third person can not operate the switches carelessly.</li> <li>● Place a sign “Under Operation” at the position easy to see.</li> <li>● For the grease for the guide or ball screw, use appropriate grease according to the Operation Manual for each model.</li> <li>● Do not perform the dielectric strength test. Failure to do so may result in a damage to the product.</li> <li>● When releasing the brake on a vertically oriented actuator, exercise precaution not to pinch your hand or damage the work parts with the actuator dropped by gravity.</li> </ul> <p>* Safety protection Fence : In the case that there is no safety protection fence, the movable range should be indicated.</p>
9	Modification and Dismantle	<ul style="list-style-type: none"> <li>● Do not modify, disassemble, assemble or use of maintenance parts not specified based at your own discretion.</li> </ul>
10	Disposal	<ul style="list-style-type: none"> <li>● When the product becomes no longer usable or necessary, dispose of it properly as an industrial waste.</li> <li>● Do not put the product in a fire when disposing of it. The product may burst or generate toxic gases.</li> </ul>

## Alert Indication

The safety precautions are divided into “Danger”, “Warning”, “Caution” and “Notice” according to the warning level, as follows, and described in the Operation Manual for each model.

Level	Degree of Danger and Damage	Symbol
Danger	This indicates an imminently hazardous situation which, if the product is not handled correctly, will result in death or serious injury.	 Danger
Warning	This indicates a potentially hazardous situation which, if the product is not handled correctly, could result in death or serious injury.	 Warning
Caution	This indicates a potentially hazardous situation which, if the product is not handled correctly, may result in minor injury or property damage.	 Caution
Notice	This indicates lower possibility for the injury, but should be kept to use this product properly.	 Notice

## 1. Overview

The open field network Profibus-DP is a multi-bit, multi-vendor network for communication of both control and data signals of the machine/line control level.

A wire-saving system can be built by connecting IAI's X-SEL, TT, RCS-C, E-Con, SCON-C, MSEL, ASEL, PSEL, SSEL, ACON, PCON, and SCON-CA controllers (hereinafter collectively and individually referred to as "Each Controller" ) to a Profibus-DP network.

ACON, PCON and SCON-CA are not specified in this operation manual. Refer to the separate ME0258 PROFIBUS-DP.

- \* For details on Profibus-DP, refer to the operation manual for the programmable controller (hereinafter referred to as "PLC" ) in which the master unit is installed. This operation manual should be used in conjunction with the operation manual for each controller. You should also assume that any usage not specifically permitted in this operation manual is prohibited.

PLC Master station

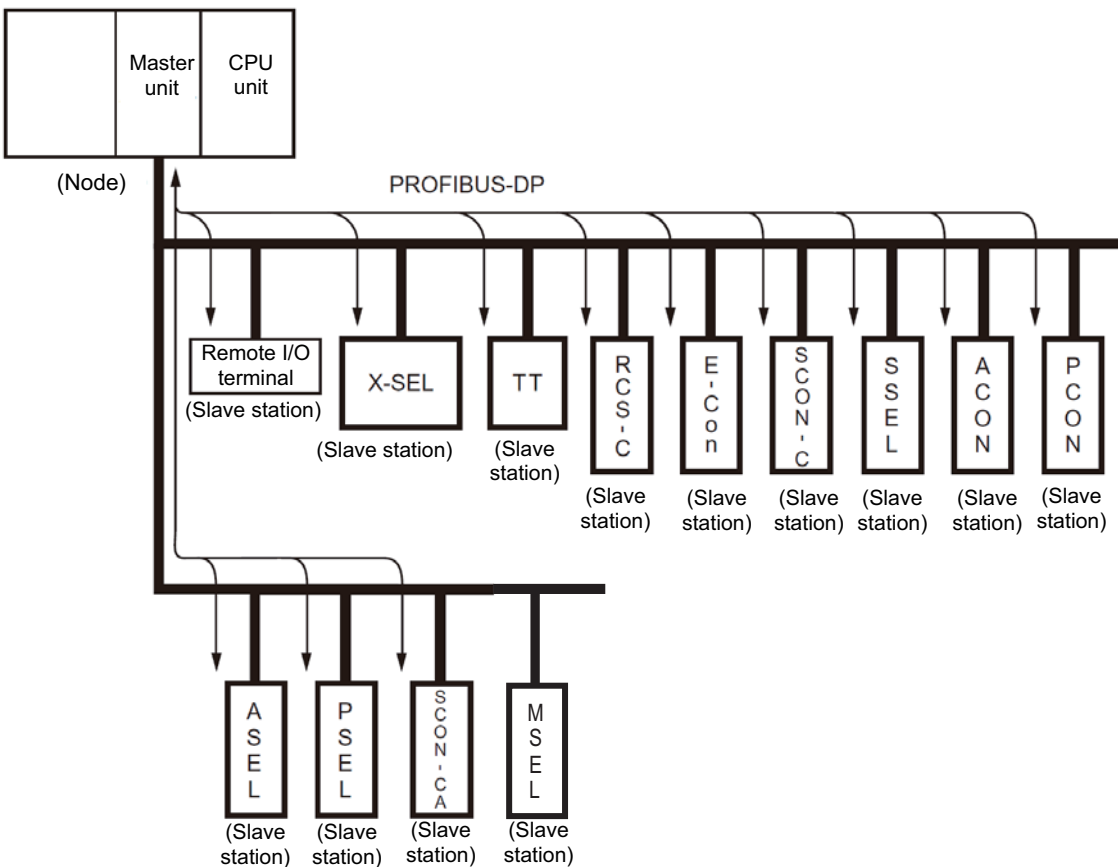

## 2. Specifications

### 2.1 Interface Specifications

The table below lists the specifications of the ProfiBus-DP interface.

Item	Specification	Remarks	
Communication profile	ProfiBus-DP		
Communication method	Hybrid method	Master/slave method with token passing	
Number of connectable stations	32 stations per segment	Up to 126 stations can be connected if a repeater is used.	
Communication data length	Maximum 244 bytes per frame		
Physical profile	RS485	* A general physical profile is RS485. * Use of a 9-pin D-sub connector is recommended for IP20 configurations.	
Baud rate (kbps)	9.6/19.2/93.75/187.5/500 1500/3000/6000/12000	*1	
Transmission distance	Maximum distance over the entire network	Baud rate	Cable type
	100 m	12,000/6,000/3,000 kbps	Type A cable
	200 m	1,500 kbps	
	400 m	500 kbps	
	1000 m	187.5 kbps	
	1200 m	9.6/19.2/93.75 kbps	
Topology	Bus/tree/star		
Cable	Single shielded twisted pair cable	Type A cable	

\*1 The baud rate of a ProfiBus-DP network can be specified only when the ProfiBus-DP network is set up using a configurator (\*2).

The baud rate of all ProfiBus-DP slave modules is set with this configurator, and therefore a different baud rate cannot be set for an individual slave station.

\*2 For the ProfiBus-DP configurator, use the configurator recommended for the master unit.

## 3. X-SEL-J/K/P/Q/JX/KX/PX/QX

### 3.1 ProfiBus-DP Board Types and Installation Positions in the X-SEL

There are six types of X-SEL controllers that support ProfiBus-DP, as listed below. The installation position of the ProfiBus-DP board is different depending on whether the X-SEL controller is of PR0 type or PR1 type.

No.	Controller type	Network I/O points (maximum inputs/outputs)	Board installation position			X-SEL model	I/O slot arrangement
			Standard slot (I/O1)	Expansion slot 1 (I/O2)	Expansion slot 2 or 3 (I/O3 or 4)		
1	J	256 / 256	○	Not available for 1-axis and 2-axis specifications.		X-SEL-J□-□-PR0-□	Fig. 3.1
2	K	256 / 256	○			X-SEL-K□-□-PR0-□	Fig. 3.2
3	K	256 / 256		*1 ○	*1 ○	X-SEL-K□-□-PR1-□	Fig. 3.3
4	P	256 / 256	Installation position of field network board			X-SEL-P-□-□-PR-□-□-□-3	Fig. 3.4
	Q	256 / 256				XSEL-Q-□-□-PR-□-□-□-3	
5	PX	256 / 256	Installation position of field network board			XSEL-PX□-□□□□□□-PR	*2
	QX	256 / 256				XSEL-QX□-□□□□□□-PR	

\*1 The PR1 board can be installed in any one of expansion I/O slots 1 to 3.

\*2 The ProfiBus-DP board is installed in the same position as shown in Fig. 3.4. With a 5-axis or 6-axis specification, the ProfiBus-DP board is installed in the same position as with a 4-axis specification.

(1) Compact type (J type)

1-axis specification\*1

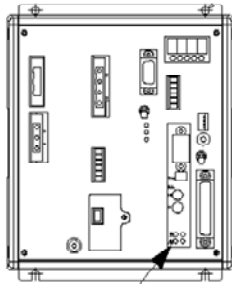

ProfiBus-DP board  
X-SEL-J□-1-PR0-□

2-axis specification\*1

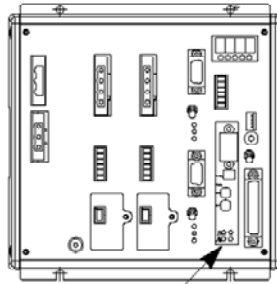

ProfiBus-DP board  
X-SEL-J□-2-PR0-□

3/4-axis specification\*2, \*3

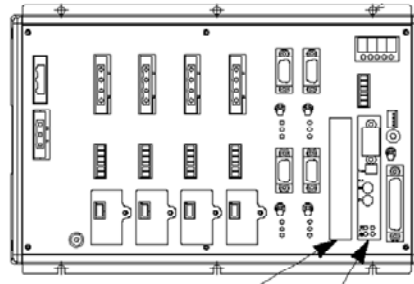

Expansion slot  
ProfiBus-DP board  
(Installed in the standard slot.)  
X-SEL-J□-3-PR0-□  
X-SEL-J□-4-PR0-□

Fig. 3.1

- \*1) An I/O board cannot be installed in 1-axis and 2-axis specifications, because the ProfiBus-DP board occupies the only slot available.
- \*2) With 3-axis and 4-axis specifications, only the “PR0” ProfiBus-DP board can be installed in the standard slot.
- \*3) With 3-axis and 4-axis specifications, one expansion I/O board can be installed in the expansion slot.  
Expansion I/O board  
Model number            [1] IA-103-X-32 (32 input points, 16 output points)  
                                 [2] IA-103-X-16 (16 input points, 32 output points)

(2) General-purpose type (K type)

- Either a ProfiBus-DP board or standard I/O board must be always installed in the standard slot (I/O1 --- slot at the far left).
- The “PR1” ProfiBus-DP board occupies two expansion slots. If this type of ProfiBus-DP board is selected, only one expansion slot can be used.
- Either an expansion I/O board\*1 or SIO board\*2 can be installed in an expansion slot.

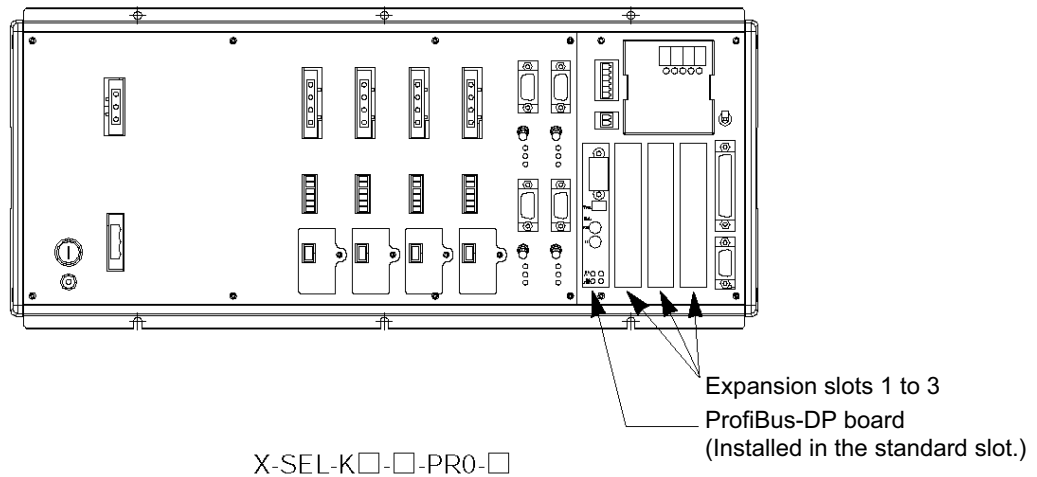

Fig. 3.2

\*1 Expansion I/O board

- Mode
- [1] IA-103-X-32 (32 input points + 16 output points, NPN specification)
  - [2] IA-103-X-32-P (32 input points + 16 output points, PNP specification)
  - [3] IA-103-X-16 (16 input points + 32 output points, NPN specification)
  - [4] IA-103-X-16-P (16 input points + 32 output points, PNP specification)
  - [5] IA-IO-3204-NP (48 input points + 48 output points, NPN specification)
  - [6] IA-IO-3204-PN (48 input points + 48 output points, PNP specification)
  - [7] IA-IO-3205-NP (48 input points + 48 output points, NPN specification)
  - [8] IA-IO-3205-PN (48 input points + 48 output points, PNP specification)
- (Note) [5] and [6] are used exclusively for the K, P and Q types, while [7] and [8] are used exclusively for the J type.

For specification details, refer to “Operation Manual for X-SEL Controller.”

\*2 SIO board

- Mode
- [1] IA-105-X-MW-A (RS232C)
  - [2] IA-105-X-MW-B (RS422C)
  - [3] IA-105-X-MW-C (RS485C)

With all boards, one board can support two channels.

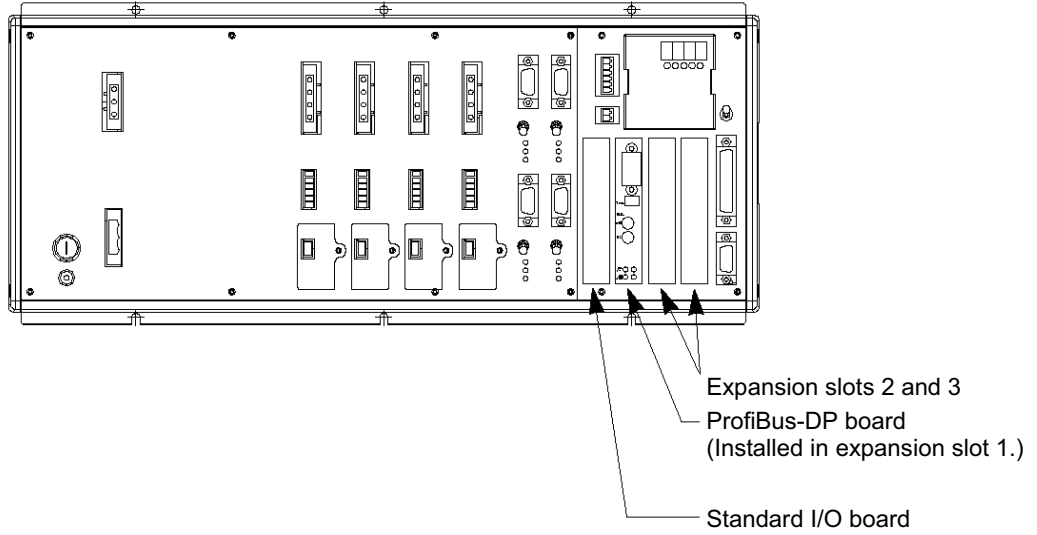

X-SEL-K□-□-PR1-□

Fig. 3.3

(3) P/Q types

- The ProfiBus-DP board is installed in the installation position of field network board.

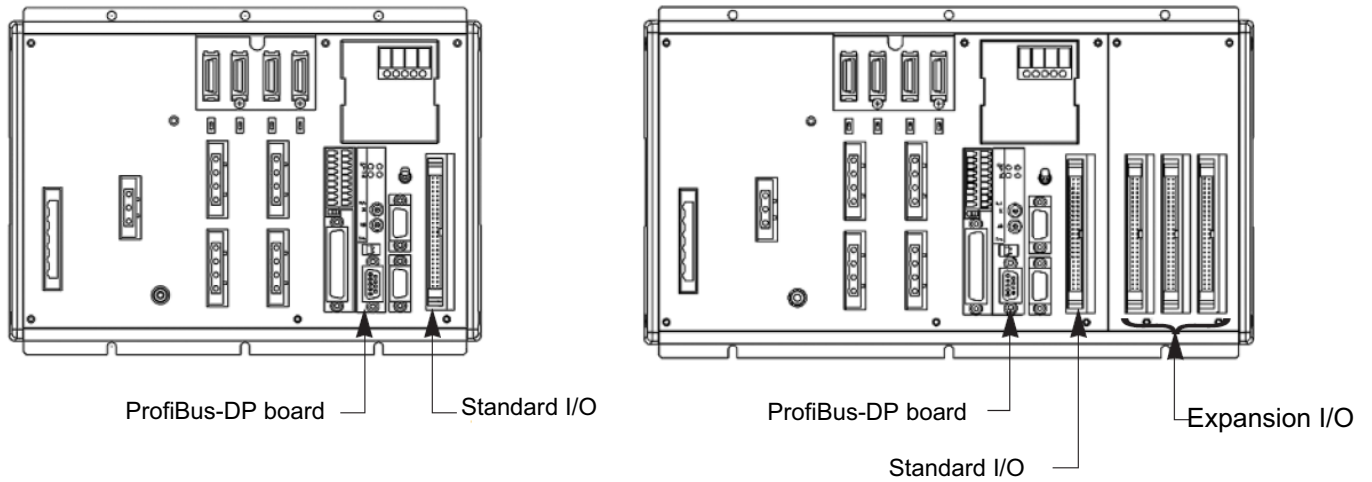

X-SEL-P-□-□-PR-□-□-□-3

X-SEL-Q-□-□-PR-□-□-□-3

Fig. 3.4

## 3.2 Setting a ProfiBus-DP Board (Slave Station)

### (1) Name of each part

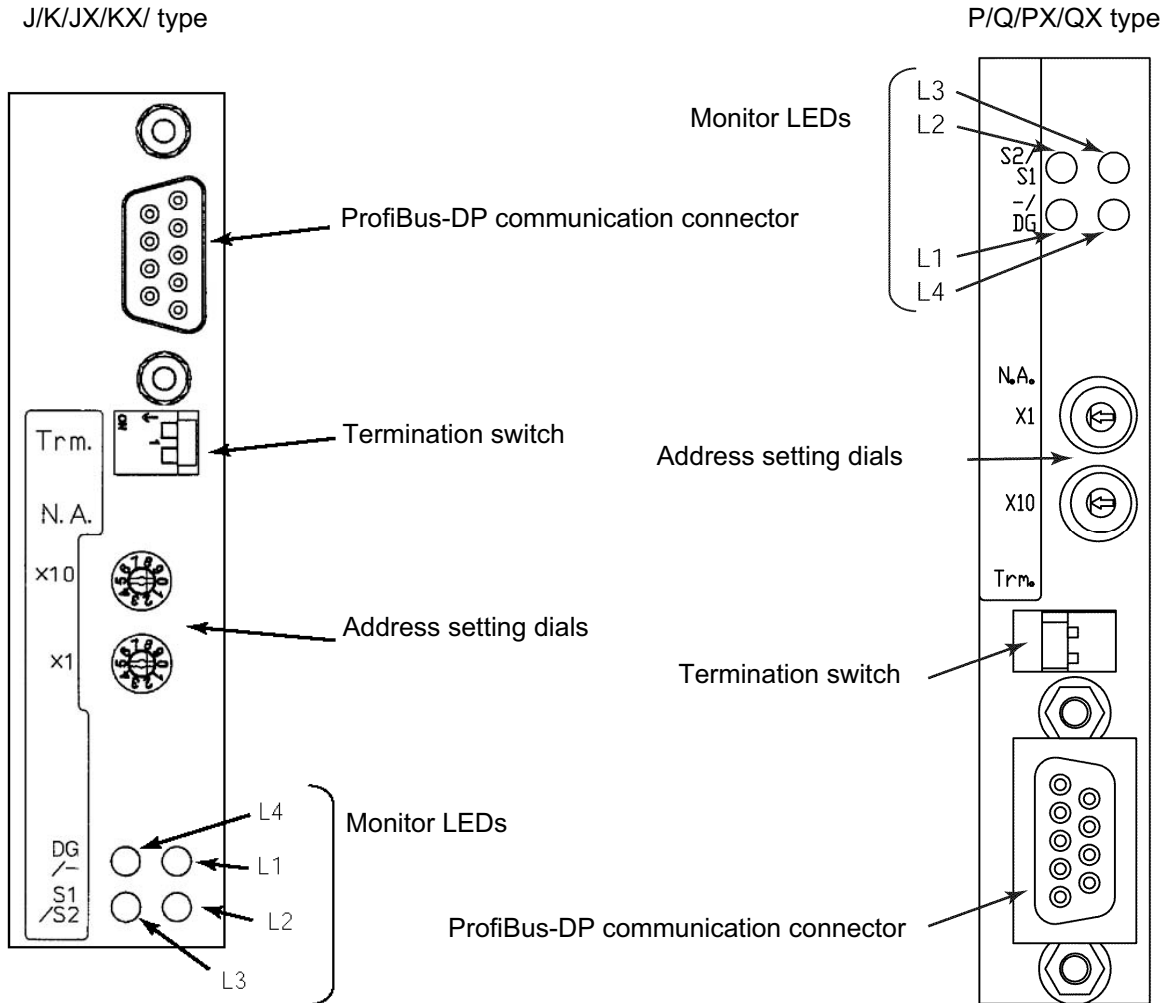

## (2) ProfiBus-DP communication connector interface specifications

This is a 9-pin, female D-sub connector recommended by the ProfiBus-DP standard EN 50170.

### Connector

Pin No.	Description	Contents
3	B-Line	RxD · TxD (Positive signal line)
5	GND	Shield
8	A-Line	/RxD · /TxD (Negative signal line)
Housing	GND	Shield

\* Pins 1, 2, 4, 6, 7 and 9 are not used (they need not be wired).

## (3) Bus termination settings <Set using the termination switch>

Among the units connected to a ProfiBus-DP network, the devices at both ends require termination to prevent reflected waves from entering the bus line again.

This ProfiBus-DP module provides a termination switch that makes this termination easy.

The user need not install a separate terminal resistor. Never install an additional terminal resistor, as it may have negative impact on bus communication or cause a communication error, etc.

### <Bus termination settings>

Termination switch ON	Termination enabled (If this switch is turned ON mistakenly when the module is connected in a position other than the end of the network, bus communication may be negatively impacted or a communication error, etc., may result.)
Termination switch OFF	Termination disabled

(4) Node address settings <Set by the address setting dials>

The address of each ProfiBus-DP slave station is set using the “x10” and “x1” rotary switches shown in the figure under (1).

Set a desired address according to the following rule:

$$\text{Node address number} = (\text{“Value set by x10” rotary switch} \times 10) + (\text{“Value set by x1” rotary switch} \times 1)$$

Example)

Target station number	Example of rotary switch settings	
	“X10” setting (x 10)	“X1” setting (x 1)
9	0	9
12	1	2

Note 1) When setting ProfiBus-DP station numbers, remember that the ProfiBus-DP master station is always assigned station number 0. Accordingly, numbers 1 to 99 are available for slave stations.

Note 2) The node address cannot be changed while the slave is communicating with the master.

(5) Monitor LED indications

LED	Color	Status	Definition	Description (cause)
L1	-	Not used	Not defined	
L2 Online	Green	Steady light	Communicating normally	<ul style="list-style-type: none"> <li>The module is operating normally (The module is connected to the fieldbus and is therefore in “online” state.)</li> </ul>
L3 Offline	Red	Steady light	Offline	<ul style="list-style-type: none"> <li>The module is not connected to the fieldbus and is therefore in “offline” state.</li> </ul>
L4 Error status	Red	Unlit	No error	-
		Blinking at 1 Hz	I/O size error	<ul style="list-style-type: none"> <li>This LED blinks when the specified I/O size is invalid.</li> </ul>
		Blinking at 2 Hz	Connection not yet established	<ul style="list-style-type: none"> <li>A system setting error (internal error)</li> </ul>
		Blinking at 4 Hz	Communication hardware error	<ul style="list-style-type: none"> <li>This LED blinks when a communication hardware error has been detected during the initialization of the system.</li> </ul>

### 3.3 Setting X-SEL I/O Parameters (Assigning I/O Ports)

Set the X-SEL input/output ports to be used in ProfiBus-DP communication. The X-SEL supports many variations of input/output port settings depending on how the applicable I/O parameters are set. (For details, refer to "Operation Manual for X-SEL Controller." All of the parameter numbers shown below indicate the I/O parameter numbers of the X-SEL controller.)

#### 3.3.1 Board Installation Positions (Slots) and I/O Parameters

I/O parameter Nos. 2 to 9

Enter the first I/O numbers among the I/Os assigned to the installed board.  
Enter "-1" for port numbers not used.

Error monitor parameter Nos. 10 to 13

In normal conditions of use, set "1" for an expansion I/O board or SIO board.  
For a ProfiBus-DP board, the setting is normally "2."

Take note that the above setting can be changed in a range of "0" to "3" at the user's responsibility.

- If set to "0" --- The controller does not monitor any error occurring in the board installed in each slot.
- If set to "1" --- The controller monitors all errors occurring in the board installed in each slot.
- If set to "2" --- The controller monitors all errors occurring in the board installed in each slot, except for errors relating to the 24-V board power supply.
- If set to "3" --- The controller monitors only errors relating to the 24-V board power supply for the board installed in each slot.

#### (1) J/JX type (compact type)

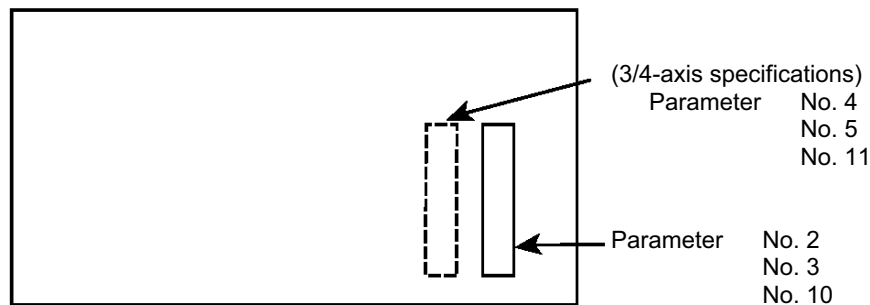

(Note) The J type has no expansion slots I/O2 and 3. With this type of controller, therefore, parameter Nos. 6 to 9 are all set to "-1," while Nos. 12 and 13 are set to "0."  
If the controller is of 1-axis or 2-axis specification, Nos. 4 and 5 are also set to "-1," while No. 11 is set to "0."

(2) K/KX type

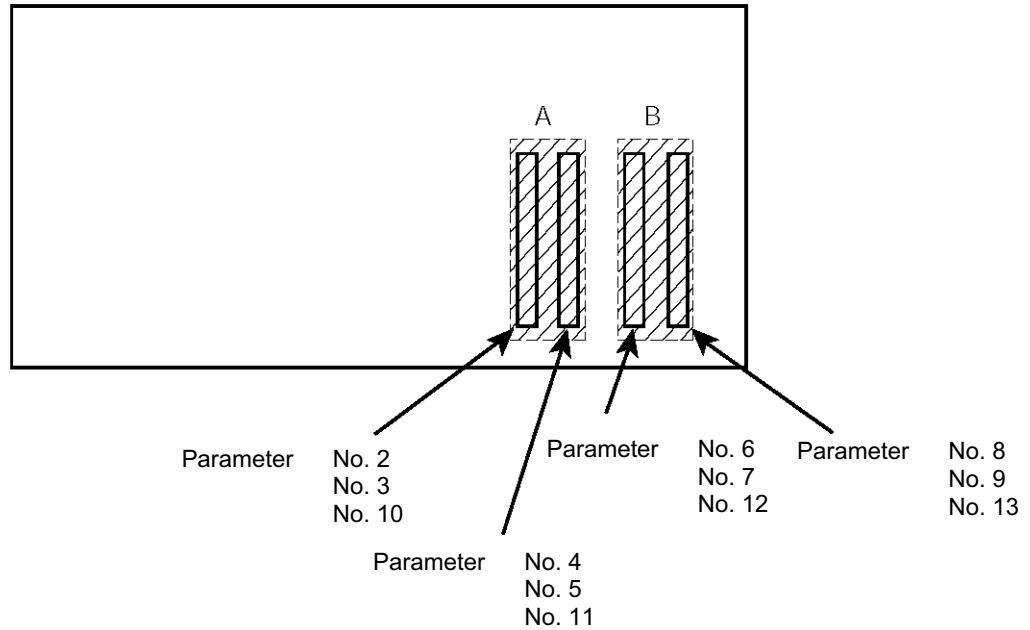

Note) One Profibus-DP board occupies two slots. Accordingly, Nos. 4 and 5 are set to “-1,” and No. 11 to “0,” when a Profibus-DP board is set in the slots denoted by A above. If a Profibus-DP board is set in the slots denoted by B, Nos. 8 and 9 are set to “-1,” while No. 13 is set to “0.”

(3) P/PX/Q/QX type

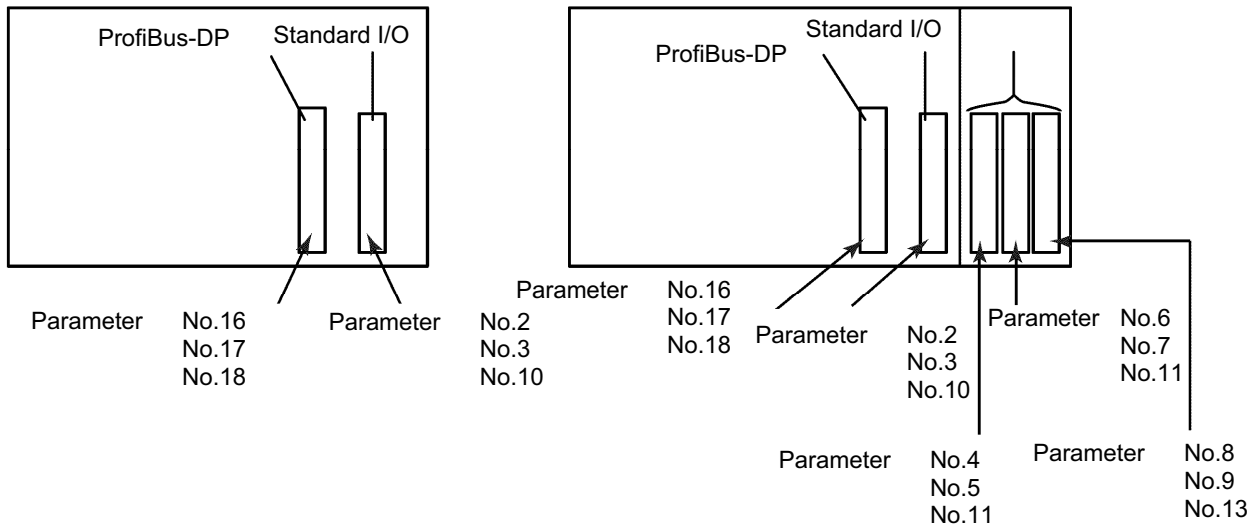

### 3.3.2 Factory-set Parameters (Default Settings)

#### (1) Factory-set parameters for the J/K/JX/KX types

A : X-SEL-J□-□-PR0-□

B : X-SEL-K□-□-PR0-□

C : X-SEL-K□-□-PR1-□

• I/O Parameter

No.	Parameter name	Input range	Settings			Remarks
			A	B	C	
1	Input/output port assignment type	0 ~ 20	0	0	0	0: Fixed assignment 1: Automatic assignment (Priority: Slot 1 ~)  * Ports are assigned automatically only for the contiguous slots in use, starting from slot 1 = For safety reasons.
2	Standard I/O fixed assignment: Initial input port number (I/O1)	-1 ~ 599	000	000	-1	0 + (multiple of 8) (The parameter is invalid if a negative value is set.)
3	Standard I/O fixed assignment: Initial output port number (I/O1)	-1 ~ 599	300	300	-1	300 + (multiple of 8) (The parameter is invalid if a negative value is set.)
4	Expansion I/O1 fixed assignment: Initial input port number (I/O2)	-1 ~ 599	-1	-1	-1	0 + (multiple of 8) (The parameter is invalid if a negative value is set.) (Slot next to standard I/O)
5	Expansion I/O1 fixed assignment: Initial output port number (I/O2)	-1 ~ 599	-1	-1	-1	300 + (multiple of 8) (The parameter is invalid if a negative value is set.)
6	Expansion I/O2 fixed assignment: Initial input port number (I/O3)	-1 ~ 599	-1	-1	000	0 + (multiple of 8) (The parameter is invalid if a negative value is set.)
7	Expansion I/O2 fixed assignment: Initial output port number (I/O3)	-1 ~ 599	-1	-1	300	300 + (multiple of 8) (The parameter is invalid if a negative value is set.)
8	Expansion I/O3 fixed assignment: Initial input port number (I/O4)	-1 ~ 599	-1	-1	-1	0 + (multiple of 8) (The parameter is invalid if a negative value is set.)
9	Expansion I/O3 fixed assignment: Initial output port number (I/O4)	-1 ~ 599	-1	-1	-1	300 + (multiple of 8) (The parameter is invalid if a negative value is set.)
10	Standard I/O error monitor	0 ~ 5	2	2	2	0: Not monitored
11	Expansion I/O1 error monitor	0 ~ 5	0	0	0	1: Monitored
12	Expansion I/O2 error monitor	0 ~ 5	0	0	2	2: Monitored (24-V I/O power errors are not monitored) (Main application version 0.55 or later)
13	Expansion I/O3 error monitor	0 ~ 5	0	0	0	3: Monitored (only 24-V I/O power errors are not monitored). (Main application version 0.55 or later)
14	Network I/F card remote input ports used	0 ~ 256	64	64	64	Multiple of 8
15	Network I/F card remote output ports used	0 ~ 256	64	64	64	Multiple of 8

(2) Factory-set parameters for the P/PX/Q/QX types

No.	Parameter name	Input range	Settings	Remarks
1	Input/output port assignment type	0 ~ 20	0	0: Fixed assignment 1: Automatic assignment (Priorities: Network I/F module → Slot 1 (standard I/O) ~) * Ports are assigned automatically only for the contiguous slots in use, starting from slot 1 = For safety reasons.
2	Standard I/O fixed assignment: Initial input port number (I/O1)	-1 ~ 599	-1	0 + (multiple of 8) (The parameter is invalid if a negative value is set.)
3	Standard I/O fixed assignment: Initial output port number (I/O1)	-1 ~ 599	-1	300 + (multiple of 8) (The parameter is invalid if a negative value is set.)
4	Expansion I/O1 fixed assignment: Initial input port number (I/O2)	-1 ~ 599	-1	0 + (multiple of 8) (The parameter is invalid if a negative value is set.) (Slot next to standard I/O)
5	Expansion I/O1 fixed assignment: Initial output port number (I/O2)	-1 ~ 599	-1	300 + (multiple of 8) (The parameter is invalid if a negative value is set.)
6	Expansion I/O2 fixed assignment: Initial input port number (I/O3)	-1 ~ 599	-1	0 + (multiple of 8) (The parameter is invalid if a negative value is set.)
7	Expansion I/O2 fixed assignment: Initial output port number (I/O3)	-1 ~ 599	-1	300 + (multiple of 8) (The parameter is invalid if a negative value is set.)
8	Expansion I/O3 fixed assignment: Initial input port number (I/O4)	-1 ~ 599	-1	0 + (multiple of 8) (The parameter is invalid if a negative value is set.)
9	Expansion I/O3 fixed assignment: Initial output port number (I/O4)	-1 ~ 599	-1	300 + (multiple of 8) (The parameter is invalid if a negative value is set.)
10	Standard I/O error monitor	0 ~ 5	0	0: Not monitored
11	Expansion I/O1 error monitor	0 ~ 5	0	1: Monitored
12	Expansion I/O2 error monitor	0 ~ 5	0	2: Monitored (24-V I/O power errors are not monitored)
13	Expansion I/O3 error monitor	0 ~ 5	0	3: Monitored (only 24-V I/O power errors are not monitored).
14	Network I/F card remote input ports used	0 ~ 256	64	Multiple of 8
15	Network I/F card remote output ports used	0 ~ 256	64	Multiple of 8
16	Network I/F module fixed assignment: Initial input port number	-1 ~ 599	0	0 + (multiple of 8) (The parameter is invalid if a negative value is set.)
17	Network I/F module fixed assignment: Initial input port number	-1 ~ 599	300	300 + (multiple of 8) (The parameter is invalid if a negative value is set.)
18	Network I/F module: Error monitor	0 ~ 5	1	0: Not monitored 1: Monitored * Some exceptions apply.

(I/O1) to (I/O4) indicate slot numbers.

### 3.3.3 Automatically Assigning X-SEL I/Os

Set the X-SEL input/output ports to be used in ProfiBus-DP communication. The X-SEL supports many variations of input/output port settings depending on how the applicable I/O parameters are set. (For details, refer to "Operation Manual for X-SEL Controller.")

This manual covers the representative setting method as explained below.

Basically, the input/output port assignment type is set to "automatic assignment" using I/O parameter No. 1, and input/output port addresses are set using Nos. 2 and 3. If an expansion I/O board is used, install the expansion I/O board in each slot number in the specified order, and I/O ports will be assigned automatically. There is no need to set the parameters for initial input/output port numbers for the expansion I/O board.

I/O parameter number	Value	Description
1	1	I/O numbers are assigned automatically.
2	0	Standard DIs are assigned from input port 0.
3	300	Standard DOs are assigned from output port 300.
14	n	The number of ProfiBus-DP input points is specified as a multiple of 16. ( $16 \leq n \leq 256$ )
15	m	The number of ProfiBus-DP output points is specified as a multiple of 16. ( $16 \leq m \leq 256$ )

### 3.3.4 Setting Examples for J/JX/K/KX Type Controllers

- (1) Setting example when only a ProfiBus-DP board is installed in the standard I/O slot (automatic assignment)  
(A ProfiBus-DP board is installed in the standard I/O slot and all expansion I/O slots are empty)

Example: In the case of automatic assignment, the following settings apply if you want to use 128 input points and 128 output points as I/O ports of the ProfiBus-DP slave station:

- [1] Enter "1" in I/O parameter No. 1 to specify automatic assignment.
- [2] Set I/O parameter No. 10, "Standard I/O error monitor" to "2."
- [3] Settings are complete by only specifying I/O parameter Nos. 14 and 15, "Input/output ports used."

X-SEL (J type, 3/4-axis specification)

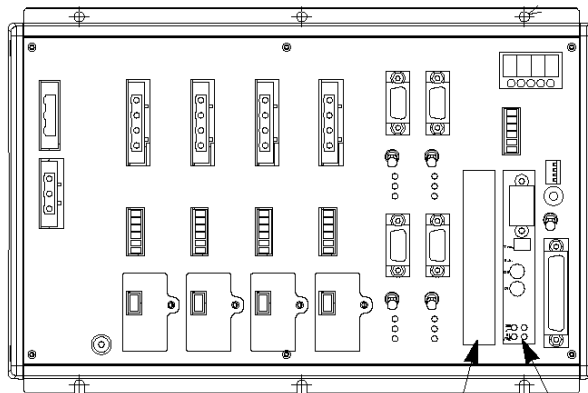

Not used  
(Not available for 1/2-axis specifications.)

Input port Nos. 000 to 015  
Output port Nos. 300 to 315

## X-SEL (K type)

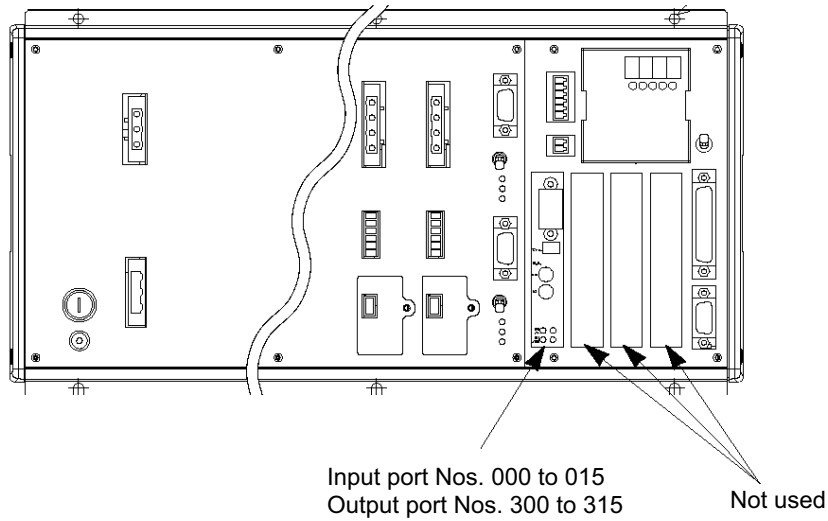

No.	Parameter name	Input range	Settings	Remarks
1	Input/output port assignment type	0 ~ 20	1	0: Fixed assignment 1: Automatic assignment (Priority: Slot 1 ~) * Ports are assigned automatically only for the contiguous slots in use, starting from slot 1 = For safety reasons.
2	Standard I/O fixed assignment: Initial input port number (I/O1)	-1 ~ 599	000	0 + (multiple of 8) (The parameter is invalid if a negative value is set.)
3	Standard I/O fixed assignment: Initial output port number (I/O1)	-1 ~ 599	300	300 + (multiple of 8) (The parameter is invalid if a negative value is set.)
4	Expansion I/O1 fixed assignment: Initial input port number (I/O2)	-1 ~ 599	-1	0 + (multiple of 8) (The parameter is invalid if a negative value is set.) (Slot next to standard I/O)
5	Expansion I/O1 fixed assignment: Initial output port number (I/O2)	-1 ~ 599	-1	300 + (multiple of 8) (The parameter is invalid if a negative value is set.)
6	Expansion I/O2 fixed assignment: Initial input port number (I/O3)	-1 ~ 599	-1	0 + (multiple of 8) (The parameter is invalid if a negative value is set.)
7	Expansion I/O2 fixed assignment: Initial output port number (I/O3)	-1 ~ 599	-1	300 + (multiple of 8) (The parameter is invalid if a negative value is set.)
8	Expansion I/O3 fixed assignment: Initial input port number (I/O4)	-1 ~ 599	-1	0 + (multiple of 8) (The parameter is invalid if a negative value is set.)
9	Expansion I/O3 fixed assignment: Initial output port number (I/O4)	-1 ~ 599	-1	300 + (multiple of 8) (The parameter is invalid if a negative value is set.)
10	Standard I/O error monitor	0 ~ 5	2	0: Not monitored
11	Expansion I/O1 error monitor	0 ~ 5	0	1: Monitored
12	Expansion I/O2 error monitor	0 ~ 5	0	2: Monitored (only 24-V I/O power errors are not monitored) (Main application version 0.55 or later)
13	Expansion I/O3 error monitor	0 ~ 5	0	3: Monitored (only 24-V I/O power errors are not monitored). (Main application version 0.55 or later)
14	Network I/F card remote input ports used	0 ~ 256	128	Multiple of 16
15	Network I/F card remote output ports used	0 ~ 256	128	Multiple of 16

(2) Setting example when a ProfiBus-DP board is used with an expansion I/O board (automatic assignment)

The port numbers of the expansion board are assigned automatically in accordance with the numbers of I/O ports of the ProfiBus-DP slave station set by I/O parameter Nos. 14 and 15.

Example: If one expansion I/O board (IA-103-X-32: 32 input points, 16 output points) is installed in expansion slot I/O1 when the maximum numbers of inputs and outputs of the ProfiBus-DP slave station are 256 and 256, respectively, entering "256" in I/O parameter Nos. 14 and 15 will automatically set I/O parameter Nos. 2 and 3, as shown below.

A ProfiBus-DP board is installed in the standard I/O slot and an expansion I/O board is installed in expansion slot I/O1.

- [1] Enter "1" in I/O parameter No. 1 to specify automatic assignment. (Default setting)
- [2] Set I/O parameter No. 10, "Standard I/O error monitor" to "2." (Default setting)
- [3] Set I/O parameter No. 11, "Standard I/O error monitor" to a value in a range of "1" to "3."
- [4] Set I/O parameter Nos. 14 and 15, "Input/output ports used." <A desired value can be set in a range of 8 to 256 (but the value must be a multiple of 8)>.

As a standard, input port numbers are assigned sequentially from No. 0. Since the ProfiBus-DP slave station already occupies 0 to 255 (total 256 points), "256" is automatically assigned as the initial input port number for expansion slot I/O1 based on fixed assignment.

On the other hand, output port numbers are assigned sequentially from No. 300 as a standard. Since the ProfiBus-DP slave station already occupies 300 to 555 (total 256 points), "556" is automatically assigned as the initial output port number expansion slot I/O1 based on fixed assignment.

X-SEL (J type, 3/4-axis specification)

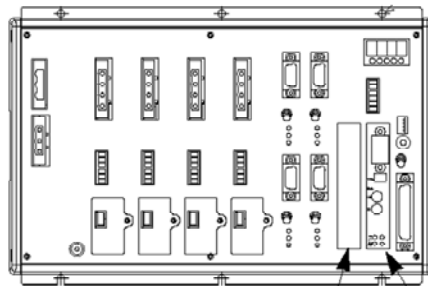

Input port Nos. 256 to 287      Input port Nos. 000 to 255  
 Output port Nos. 556 to 571      Output port Nos. 300 to 555

X-SEL (K type)

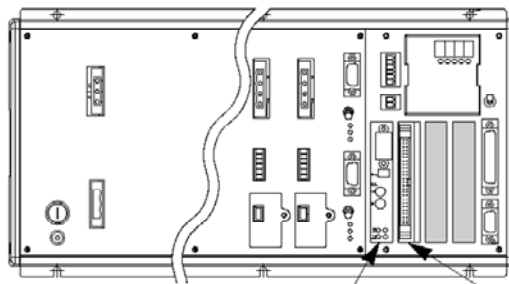

Input port Nos. 000 to 255      Input port Nos. 256 to 287  
 Output port Nos. 300 to 555      Output port Nos. 556 to 571

No.	Parameter name	Input range	Settings	Remarks
1	Input/output port assignment type	0 ~ 20	1	0: Fixed assignment 1: Automatic assignment (Priority: Slot 1 ~) * Ports are assigned automatically only for the contiguous slots in use, starting from slot 1 = For safety reasons.
2	Standard I/O fixed assignment: Initial input port number (I/O1)	-1 ~ 599	000	0 + (multiple of 8) (The parameter is invalid if a negative value is set.)
3	Standard I/O fixed assignment: Initial output port number (I/O1)	-1 ~ 599	300	300 + (multiple of 8) (The parameter is invalid if a negative value is set.)
4	Expansion I/O1 fixed assignment: Initial input port number (I/O2)	-1 ~ 599	256	0 + (multiple of 8) (The parameter is invalid if a negative value is set.) (Slot next to standard I/O)
5	Expansion I/O1 fixed assignment: Initial output port number (I/O2)	-1 ~ 599	556	300 + (multiple of 8) (The parameter is invalid if a negative value is set.)
6	Expansion I/O2 fixed assignment: Initial input port number (I/O3)	-1 ~ 599	-1	0 + (multiple of 8) (The parameter is invalid if a negative value is set.)
7	Expansion I/O2 fixed assignment: Initial output port number (I/O3)	-1 ~ 599	-1	300 + (multiple of 8) (The parameter is invalid if a negative value is set.)
8	Expansion I/O3 fixed assignment: Initial input port number (I/O4)	-1 ~ 599	-1	0 + (multiple of 8) (The parameter is invalid if a negative value is set.)
9	Expansion I/O3 fixed assignment: Initial output port number (I/O4)	-1 ~ 599	-1	300 + (multiple of 8) (The parameter is invalid if a negative value is set.)
10	Standard I/O error monitor	0 ~ 5	2	0: Not monitored
11	Expansion I/O1 error monitor	0 ~ 5	1	1: Monitored
12	Expansion I/O2 error monitor	0 ~ 5	0	2: Monitored (only 24-V I/O power errors are not monitored)
13	Expansion I/O3 error monitor	0 ~ 5	0	3: Monitored (only 24-V I/O power errors are not monitored). (Main application version 0.55 or later)
14	Network I/F card remote input ports used	0 ~ 256	256	Multiple of 16
15	Network I/F card remote output ports used	0 ~ 256	256	Multiple of 16

(3) Setting example when a ProfiBus-DP board is used with an expansion I/O board (fixed assignment)

Under fixed assignment (where I/O parameter No. 1 is set to "0"), you can set desired initial I/O port numbers.

Under automatic assignment the initial I/O port numbers (input number 0 ~ / output number 300 ~) can only be set after the standard I/Os have been assigned. Under fixed assignment, on the other hand, the initial I/O port numbers (input number 0 ~ / output number 300 ~) can be set freely for other boards installed in expansion slots I/O1 to 3.

Example: One expansion I/O board (IA-103-X-32: 32 input points, 16 output points) is installed in expansion slot I/O1 when the numbers of inputs and outputs of the ProfiBus-DP slave station are 256 and 256, respectively. If the assignments as shown below are performed, the expansion I/O board is assigned for the initial I/O port numbers (input number 0 ~ / output number 300 ~), and the ProfiBus-DP slave station installed in the standard I/O slot is assigned for the subsequent numbers.

- [1] Enter "1" in I/O parameter No. 1 to specify fixed assignment.
  - [2] Set I/O parameter No. 4, "Expansion I/O 1 fixed assignment: Initial input port number" to "0."
  - [3] Set I/O parameter No. 5, "Expansion I/O 1 fixed assignment: Initial output port number" to "300."
  - [4] Since the expansion I/O board IA-103-X-32 has 32 input points and 16 output points, the last expansion input port number becomes 31, while the last expansion output port number becomes 15.
  - [5] Set I/O parameter No. 2, "Standard I/O 1 fixed assignment: Initial input port number" to "32."
  - [6] Set I/O parameter No. 3, "Standard I/O 1 fixed assignment: Initial output port number" to "16."
  - [7] Set I/O parameter No. 10, "Standard I/O error monitor" to "2."
  - [8] Set I/O parameter No. 11, "Standard I/O error monitor" to a value in a range of "1" to "3."
  - [9] Since the maximum numbers of input and output points of the ProfiBus-DP slave station are 256 and 256, respectively, enter "256" in I/O parameter Nos. 14 and 15, "Input/output ports used."
- The settings are complete.

X-SEL (K type)

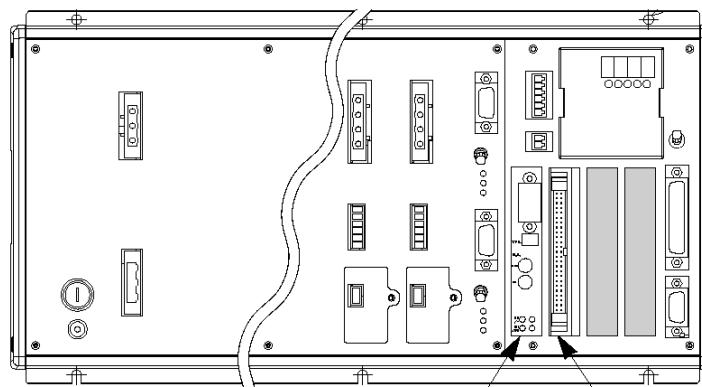

Input port Nos. 032 to 287  
Output port Nos. 316 to 571

Input port Nos. 000 to 031  
Output port Nos. 300 to 315

No.	Parameter name	Input range	Settings	Remarks
1	Input/output port assignment type	0 ~ 20	1	0: Fixed assignment 1: Automatic assignment (Priority: Slot 1 ~) * Ports are assigned automatically only for the contiguous slots in use, starting from slot 1 = For safety reasons.
2	Standard I/O fixed assignment: Initial input port number (I/O1)	-1 ~ 599	032	0 + (multiple of 8) (The parameter is invalid if a negative value is set.)
3	Standard I/O fixed assignment: Initial output port number (I/O1)	-1 ~ 599	316	300 + (multiple of 8) (The parameter is invalid if a negative value is set.)
4	Expansion I/O1 fixed assignment: Initial input port number (I/O2)	-1 ~ 599	000	0 + (multiple of 8) (The parameter is invalid if a negative value is set.) (Slot next to standard I/O)
5	Expansion I/O1 fixed assignment: Initial output port number (I/O2)	-1 ~ 599	300	300 + (multiple of 8) (The parameter is invalid if a negative value is set.)
6	Expansion I/O2 fixed assignment: Initial input port number (I/O3)	-1 ~ 599	-1	0 + (multiple of 8) (The parameter is invalid if a negative value is set.)
7	Expansion I/O2 fixed assignment: Initial output port number (I/O3)	-1 ~ 599	-1	300 + (multiple of 8) (The parameter is invalid if a negative value is set.)
8	Expansion I/O3 fixed assignment: Initial input port number (I/O4)	-1 ~ 599	-1	0 + (multiple of 8) (The parameter is invalid if a negative value is set.)
9	Expansion I/O3 fixed assignment: Initial output port number (I/O4)	-1 ~ 599	-1	300 + (multiple of 8) (The parameter is invalid if a negative value is set.)
10	Standard I/O error monitor	0 ~ 5	1	0: Not monitored
11	Expansion I/O1 error monitor	0 ~ 5	2	1: Monitored
12	Expansion I/O2 error monitor	0 ~ 5	0	2: Monitored (only 24-V I/O power errors are not monitored)
13	Expansion I/O3 error monitor	0 ~ 5	0	3: Monitored (only 24-V I/O power errors are not monitored). (Main application version 0.55 or later)
14	Network I/F card remote input ports used	0 ~ 256	256	Multiple of 16
15	Network I/F card remote output ports used	0 ~ 256	256	Multiple of 16

### 3.3.5 Setting Examples for P/PX/Q/QX Type Controllers

#### (1) Setting example when only a ProfiBus-DP board is used (automatic assignment)

Example: The following settings apply when the I/O ports of the ProfiBus-DP board are used by 32 input points and 16 output points, each from the beginning, by leaving other I/O ports unused, just like when a standard X-SEL I/O board (50-pin connector) is used.

- [1] Enter "1" in I/O parameter No. 1 to specify automatic assignment. (Default setting)
- [2] Set I/O parameter No. 10, "Standard I/O error monitor" to "2." (Default setting)
- [3] Set I/O parameter Nos. 14 and 15, "Input/output ports used," and the settings are complete. <A desired value can be set in a range of 0 to 256 (but the value must be a multiple of 16)>.

3. X-SEL-J/K/P/Q/JX/KX/IX/QX

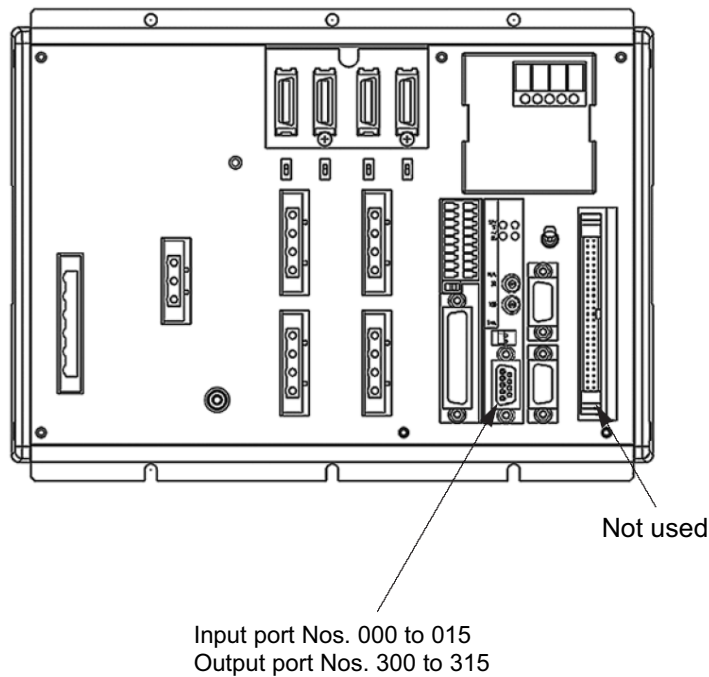

## I/O Parameters of X-SEL P/PX/Q/QX Type Controllers

No.	Parameter name	Default (reference)	Input range	Setting	Remarks
1	Input/output port assignment type	0	0 ~ 20	1	0: Fixed assignment 1: Automatic assignment (Priorities: Network I/F module → Slot 1 (standard I/O) ~) * Ports are assigned automatically only for the contiguous slots in use, starting from slot 1 = For safety reasons.
2	Standard I/O fixed assignment: Initial input port number (I/O1)	-1	-1 ~ 599	-1	0 + (multiple of 8) (The parameter is invalid if a negative value is set.)
3	Standard I/O fixed assignment: Initial output port number (I/O1)	-1	-1 ~ 599	-1	300 + (multiple of 8) (The parameter is invalid if a negative value is set.)
4	Expansion I/O1 fixed assignment: Initial input port number (I/O2)	-1	-1 ~ 599	-1	0 + (multiple of 8) (The parameter is invalid if a negative value is set.) (Slot next to standard I/O)
5	Expansion I/O1 fixed assignment: Initial output port number (I/O2)	-1	-1 ~ 599	-1	300 + (multiple of 8) (The parameter is invalid if a negative value is set.)
6	Expansion I/O2 fixed assignment: Initial input port number (I/O3)	-1	-1 ~ 599	-1	0 + (multiple of 8) (The parameter is invalid if a negative value is set.)
7	Expansion I/O2 fixed assignment: Initial output port number (I/O3)	-1	-1 ~ 599	-1	300 + (multiple of 8) (The parameter is invalid if a negative value is set.)
8	Expansion I/O3 fixed assignment: Initial input port number (I/O4)	-1	-1 ~ 599	-1	0 + (multiple of 8) (The parameter is invalid if a negative value is set.)
9	Expansion I/O3 fixed assignment: Initial output port number (I/O4)	-1	-1 ~ 599	-1	300 + (multiple of 8) (The parameter is invalid if a negative value is set.)
10	Standard I/O error monitor	0	0 ~ 5	0	0: Not monitored 1: Monitored 2: Monitored (24-V I/O power errors are not monitored) 3: Monitored (only 24-V I/O power errors are not monitored).
11	Expansion I/O1 error monitor	0	0 ~ 5	0	
12	Expansion I/O2 error monitor	0	0 ~ 5	0	
13	Expansion I/O3 error monitor	0	0 ~ 5	0	
14	Network I/F card remote input ports used	64	0 ~ 256	32	Multiple of 8
15	Network I/F card remote output ports used	64	0 ~ 256	16	Multiple of 8
16	Network I/F module fixed assignment: Initial input port number	0	-1 ~ 599	0	0 + (multiple of 8) (The parameter is invalid if a negative value is set.)
17	Network I/F module fixed assignment: Initial input port number	300	-1 ~ 599	300	300 + (multiple of 8) (The parameter is invalid if a negative value is set.)
18	Network I/F module: Error monitor	1	0 ~ 5	1	0: Not monitored 1: Monitored * Some exceptions apply.

(I/O1) to (I/O4) indicate slot numbers.

(2) Setting example when a Profibus-DP board is used with a standard I/O board (automatic assignment)

Example: These settings are used when 256 input points and 256 output points are assigned, both from the initial standard I/O ports, to the Profibus-DP board, and the remaining I/O port numbers are assigned to the standard I/O board.

- [1] Enter "1" in I/O parameter No. 1 to specify automatic assignment.
- [2] Set I/O parameter No. 10, "Standard I/O error monitor" to "2."
- [3] Set I/O parameter No. 11, "Standard I/O error monitor" to "1," "2" or "3."
- [4] Set I/O parameter Nos. 14 and 15, "Input/output ports used," and the settings are complete. <A desired value can be set in a range of 0 to 256 (but the value must be a multiple of 8)>.

Port numbers are automatically assigned to the expansion I/O board according to the numbers of I/O ports of the Profibus-DP slave station that have been set by I/O parameter Nos. 14 and 15.

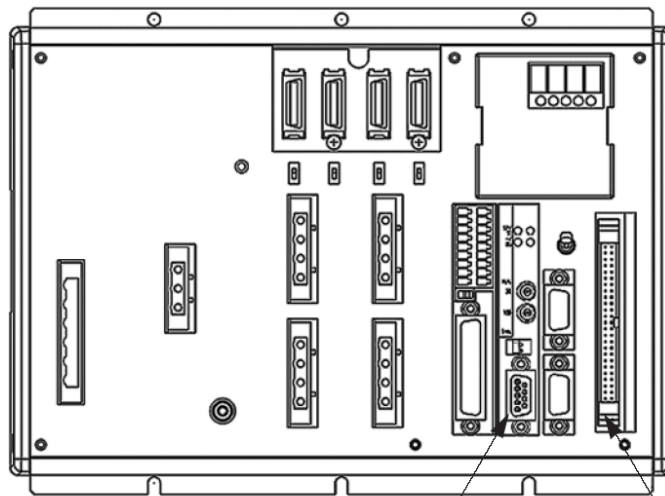

Input port Nos. 000 to 255  
Output port Nos. 300 to 555

Input port Nos. 256 to 287  
Output port Nos. 556 to 571

## I/O Parameters of X-SEL P/PX/Q/QX Type Controllers

No.	Parameter name	Default (reference)	Input range	Setting	Remarks
1	Input/output port assignment type	0	0 ~ 20	1	0: Fixed assignment 1: Automatic assignment (Priorities: Network I/F module → Slot 1 (standard I/O) ~) * Ports are assigned automatically only for the contiguous slots in use, starting from slot 1 = For safety reasons.
2	Standard I/O fixed assignment: Initial input port number (I/O1)	-1	-1 ~ 599	256	0 + (multiple of 8) (The parameter is invalid if a negative value is set.)
3	Standard I/O fixed assignment: Initial output port number (I/O1)	-1	-1 ~ 599	556	300 + (multiple of 8) (The parameter is invalid if a negative value is set.)
4	Expansion I/O1 fixed assignment: Initial input port number (I/O2)	-1	-1 ~ 599	-1	0 + (multiple of 8) (The parameter is invalid if a negative value is set.) (Slot next to standard I/O)
5	Expansion I/O1 fixed assignment: Initial output port number (I/O2)	-1	-1 ~ 599	-1	300 + (multiple of 8) (The parameter is invalid if a negative value is set.)
6	Expansion I/O2 fixed assignment: Initial input port number (I/O3)	-1	-1 ~ 599	-1	0 + (multiple of 8) (The parameter is invalid if a negative value is set.)
7	Expansion I/O2 fixed assignment: Initial output port number (I/O3)	-1	-1 ~ 599	-1	300 + (multiple of 8) (The parameter is invalid if a negative value is set.)
8	Expansion I/O3 fixed assignment: Initial input port number (I/O4)	-1	-1 ~ 599	-1	0 + (multiple of 8) (The parameter is invalid if a negative value is set.)
9	Expansion I/O3 fixed assignment: Initial output port number (I/O4)	-1	-1 ~ 599	-1	300 + (multiple of 8) (The parameter is invalid if a negative value is set.)
10	Standard I/O error monitor	0	0 ~ 5	1	0: Not monitored 1: Monitored 2: Monitored (24-V I/O power errors are not monitored) 3: Monitored (only 24-V I/O power errors are not monitored).
11	Expansion I/O1 error monitor	0	0 ~ 5	0	
12	Expansion I/O2 error monitor	0	0 ~ 5	0	
13	Expansion I/O3 error monitor	0	0 ~ 5	0	
14	Network I/F card remote input ports used	64	0 ~ 256	256	Multiple of 16
15	Network I/F card remote output ports used	64	0 ~ 256	256	Multiple of 16
16	Network I/F module fixed assignment: Initial input port number	0	-1 ~ 599	0	0 + (multiple of 8) (The parameter is invalid if a negative value is set.)
17	Network I/F module fixed assignment: Initial input port number	300	-1 ~ 599	300	300 + (multiple of 8) (The parameter is invalid if a negative value is set.)
18	Network I/F module: Error monitor	1	0 ~ 5	1	0: Not monitored 1: Monitored * Some exceptions apply.

(I/O1) to (I/O4) indicate slot numbers.

- (3) Setting example when a ProfiBus-DP board is used with a standard I/O board (fixed assignment)  
 In automatic assignment, the initial I/O port numbers (No. 0 or greater for input / No. 300 or greater for output) must be set on the standard I/O board. By using fixed assignment, however, you can set the initial I/O port numbers on expansion I/O board 1 to 3 (No. 0 or greater for input / No. 300 or greater for output), other than the standard I/O board.

Example: Assume the ProfiBus-DP slave station has 256 input points and 256 output points and an expansion I/O board (IA-103-X-32: 32 input points, 16 output points) is installed in the expansion I/O1 slot. If you want to assign the ports as follows, then assign the initial I/O port numbers (No. 0 or greater for input / No. 300 or greater for output) to the expansion I/O board, and then assign the remaining port numbers to the ProfiBus-DP slave station installed in the standard I/O slot.

- [1] Enter "1" in I/O parameter No. 1 to specify fixed assignment.
- [2] Set I/O parameter No. 4, "Expansion I/O1 fixed assignment: Initial input port number" to "0."
- [3] Set I/O parameter No. 5, "Expansion I/O1 fixed assignment: Initial output port number" to "300."
- [4] Since the expansion I/O board IA-103-X-32 has 32 input points and 16 output points, the last I/O port numbers on the expansion I/O board are 31 for input and 15 for output.
- [5] Set I/O parameter No. 2, "Standard I/O fixed assignment: Initial input port number" to "32."
- [6] Set I/O parameter No. 3, "Standard I/O fixed assignment: Initial output port number" to "16."
- [7] Set I/O parameter No. 10, "Standard I/O error monitor" to "2."
- [8] Set I/O parameter No. 11, "Standard I/O error monitor" to "1," "2" or "3."
- [9] Since the maximum values of 256 and 256 are used for inputs and outputs of the ProfiBus-DP slave station, enter "256" in both I/O parameter Nos. 14 and 15, "Input/output ports used." The settings are complete.

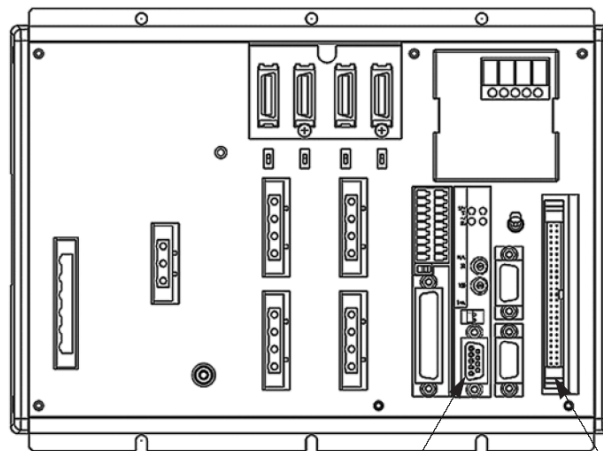

Input port Nos. 000 to 031  
 Output port Nos. 300 to 315

Input port Nos. 032 to 287  
 Output port Nos. 316 to 571

## I/O Parameters of X-SEL P/PX/Q/QX Type Controllers

No.	Parameter name	Default (reference)	Input range	Setting	Remarks
1	Input/output port assignment type	0	0 ~ 20	1	0: Fixed assignment 1: Automatic assignment (Priorities: Network I/F module → Slot 1 (standard I/O) ~) * Ports are assigned automatically only for the contiguous slots in use, starting from slot 1 = For safety reasons.
2	Standard I/O fixed assignment: Initial input port number (I/O1)	-1	-1 ~ 599	000	0 + (multiple of 8) (The parameter is invalid if a negative value is set.)
3	Standard I/O fixed assignment: Initial output port number (I/O1)	-1	-1 ~ 599	300	300 + (multiple of 8) (The parameter is invalid if a negative value is set.)
4	Expansion I/O1 fixed assignment: Initial input port number (I/O2)	-1	-1 ~ 599	-1	0 + (multiple of 8) (The parameter is invalid if a negative value is set.) (Slot next to standard I/O)
5	Expansion I/O1 fixed assignment: Initial output port number (I/O2)	-1	-1 ~ 599	-1	300 + (multiple of 8) (The parameter is invalid if a negative value is set.)
6	Expansion I/O2 fixed assignment: Initial input port number (I/O3)	-1	-1 ~ 599	-1	0 + (multiple of 8) (The parameter is invalid if a negative value is set.)
7	Expansion I/O2 fixed assignment: Initial output port number (I/O3)	-1	-1 ~ 599	-1	300 + (multiple of 8) (The parameter is invalid if a negative value is set.)
8	Expansion I/O3 fixed assignment: Initial input port number (I/O4)	-1	-1 ~ 599	-1	0 + (multiple of 8) (The parameter is invalid if a negative value is set.)
9	Expansion I/O3 fixed assignment: Initial output port number (I/O4)	-1	-1 ~ 599	-1	300 + (multiple of 8) (The parameter is invalid if a negative value is set.)
10	Standard I/O error monitor	0	0 ~ 5	1	0: Not monitored
11	Expansion I/O1 error monitor	0	0 ~ 5	0	1: Monitored
12	Expansion I/O2 error monitor	0	0 ~ 5	0	2: Monitored (24-V I/O power errors are not monitored)
13	Expansion I/O3 error monitor	0	0 ~ 5	0	3: Monitored (only 24-V I/O power errors are not monitored).
14	Network I/F card remote input ports used	64	0 ~ 256	256	Multiple of 8
15	Network I/F card remote output ports used	64	0 ~ 256	256	Multiple of 8
16	Network I/F module fixed assignment: Initial input port number	0	-1 ~ 599	032	0 + (multiple of 8) (The parameter is invalid if a negative value is set.)
17	Network I/F module fixed assignment: Initial output port number	300	-1 ~ 599	316	300 + (multiple of 8) (The parameter is invalid if a negative value is set.)
18	Network I/F module: Error monitor	1	0 ~ 5	1	0: Not monitored 1: Monitored * Some exceptions apply.

(I/O1) to (I/O4) indicate slot numbers.

### 3.3.6 X-SEL I/O Port Numbers

The standard I/O port numbers of the X-SEL are listed below.  
 The port numbers and function assignments of the X-SEL can be changed using I/O parameters.  
 (For details, refer to “Operation Manual for X-SEL Controller.”)

	Port No.	Function		Port No.	Function
Input	000	Program start	Output	300	Alarm output
	001	General-purpose input		301	Ready output
	002	General-purpose input		302	Emergency stop output
	003	General-purpose input		303	General-purpose output
	004	General-purpose input		304	General-purpose output
	005	General-purpose input		305	General-purpose output
	006	General-purpose input		306	General-purpose output
	007	Program specification (PRG No. 1)		307	General-purpose output
	008	Program specification (PRG No. 2)		308	General-purpose output
	009	Program specification (PRG No. 4)		309	General-purpose output
	010	Program specification (PRG No. 8)		310	General-purpose output
	011	Program specification (PRG No. 10)		311	General-purpose output
	012	Program specification (PRG No. 20)		312	General-purpose output
	013	Program specification (PRG No. 40)		313	General-purpose output
	014	General-purpose input		314	General-purpose output
015	General-purpose input	315	General-purpose output		

(Note) The above functions are based on the factory-set default parameter settings.

### 3.3.7 Correspondence of X-SEL I/O Port Numbers and PLC Addresses

When the X-SEL's ProfiBus-DP board I/Os are assigned in the input/output (memory) areas of the PLC, the areas that occupy the PLC memory will change depending on the numbers of I/O points set on the X-SEL side.

ProfiBus-DP board I/Os are assigned in units of 16 bits (16 I/O points); i.e., they are assigned in units of words.

The below illustrates the relationship of X-SEL I/O port numbers and PLC I/O addresses according to the X-SEL's I/O parameter settings.

- 1) Example of system configuration  
An example of system configuration is shown below.

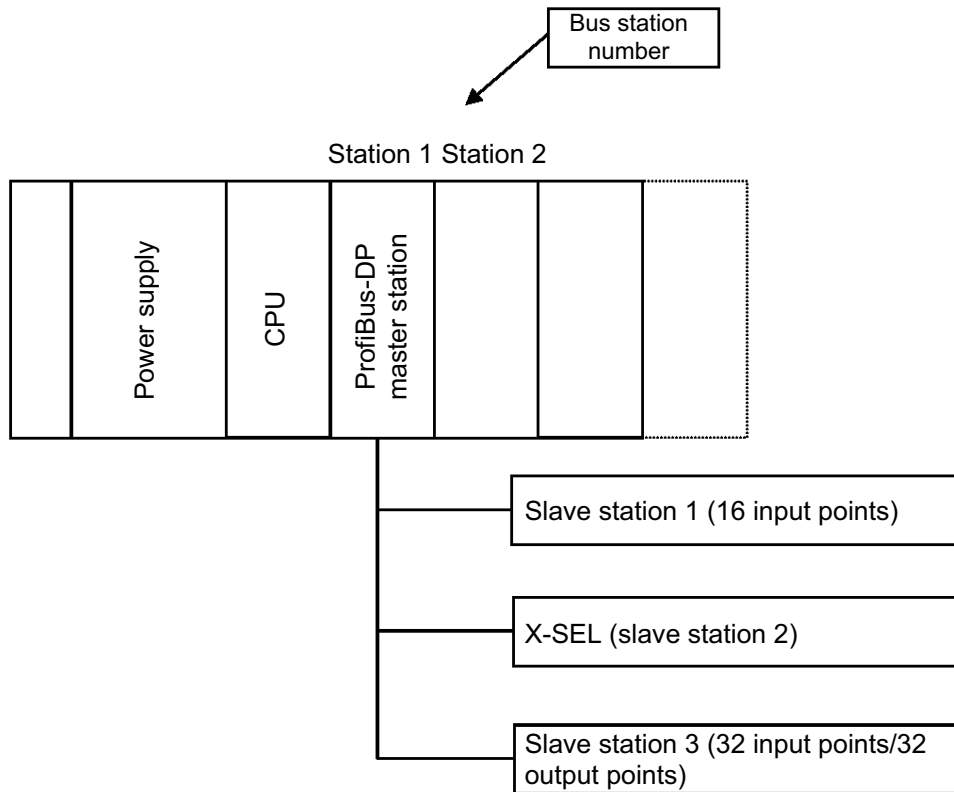

- 2) Address assignment in the master station  
When setting the configuration in 1) using a configurator, the numbers of inputs and outputs of the X-SEL set for slave station 2 must be determined. (Here, it is assumed that the number of occupiable slave stations is set to 16 words in the master station.)
- 3) When the X-SEL conforming to the configuration example shown in 1) has total eight words of input and output points (128 points), respectively.

The X-SEL's I/O parameters are set as follows.

No.	Parameter name	Input range	Settings	Remarks
1	Input/output port assignment type	0 ~ 20	1	0: Fixed assignment 1: Automatic assignment (Priority: Slot 1 ~) * Ports are assigned automatically only for the contiguous slots in use, starting from slot 1 = For safety reasons.
2	Standard I/O fixed assignment: Initial input port number (I/O1)	-1 ~ 599	000	0 + (multiple of 8) (The parameter is invalid if a negative value is set.)
3	Standard I/O fixed assignment: Initial output port number (I/O1)	-1 ~ 599	300	300 + (multiple of 8) (The parameter is invalid if a negative value is set.)
4	Expansion I/O1 fixed assignment: Initial input port number (I/O2)	-1 ~ 599	-1	0 + (multiple of 8) (The parameter is invalid if a negative value is set.) (Slot next to standard I/O)
5	Expansion I/O1 fixed assignment: Initial output port number (I/O2)	-1 ~ 599	-1	300 + (multiple of 8) (The parameter is invalid if a negative value is set.)
6	Expansion I/O2 fixed assignment: Initial input port number (I/O3)	-1 ~ 599	-1	0 + (multiple of 8) (The parameter is invalid if a negative value is set.)
7	Expansion I/O2 fixed assignment: Initial output port number (I/O3)	-1 ~ 599	-1	300 + (multiple of 8) (The parameter is invalid if a negative value is set.)
8	Expansion I/O3 fixed assignment: Initial input port number (I/O4)	-1 ~ 599	-1	0 + (multiple of 8) (The parameter is invalid if a negative value is set.)
9	Expansion I/O3 fixed assignment: Initial output port number (I/O4)	-1 ~ 599	-1	300 + (multiple of 8) (The parameter is invalid if a negative value is set.)
10	Standard I/O error monitor	0 ~ 5	2	0: Not monitored 1: Monitored 2: Monitored (only 24-V I/O power errors are not monitored) (Main application version 0.55 or later) 3: Monitored (only 24-V I/O power errors are not monitored). (Main application version 0.55 or later)
11	Expansion I/O1 error monitor	0 ~ 5	0	
12	Expansion I/O2 error monitor	0 ~ 5	0	
13	Expansion I/O3 error monitor	0 ~ 5	0	
14	Network I/F card remote input ports used	0 ~ 256	64	Multiple of 16
15	Network I/F card remote output ports used	0 ~ 256	64	Multiple of 16

- 4) I/O port numbers are assigned in units of 16 points starting from the channel address in the PLC buffer memory corresponding to the specified node address. Here, the PLC buffer memory bits are sequentially assigned to the I/O port numbers, starting from the smallest port number and lowest memory bits. Accordingly, the PLC addresses are assigned as follows.

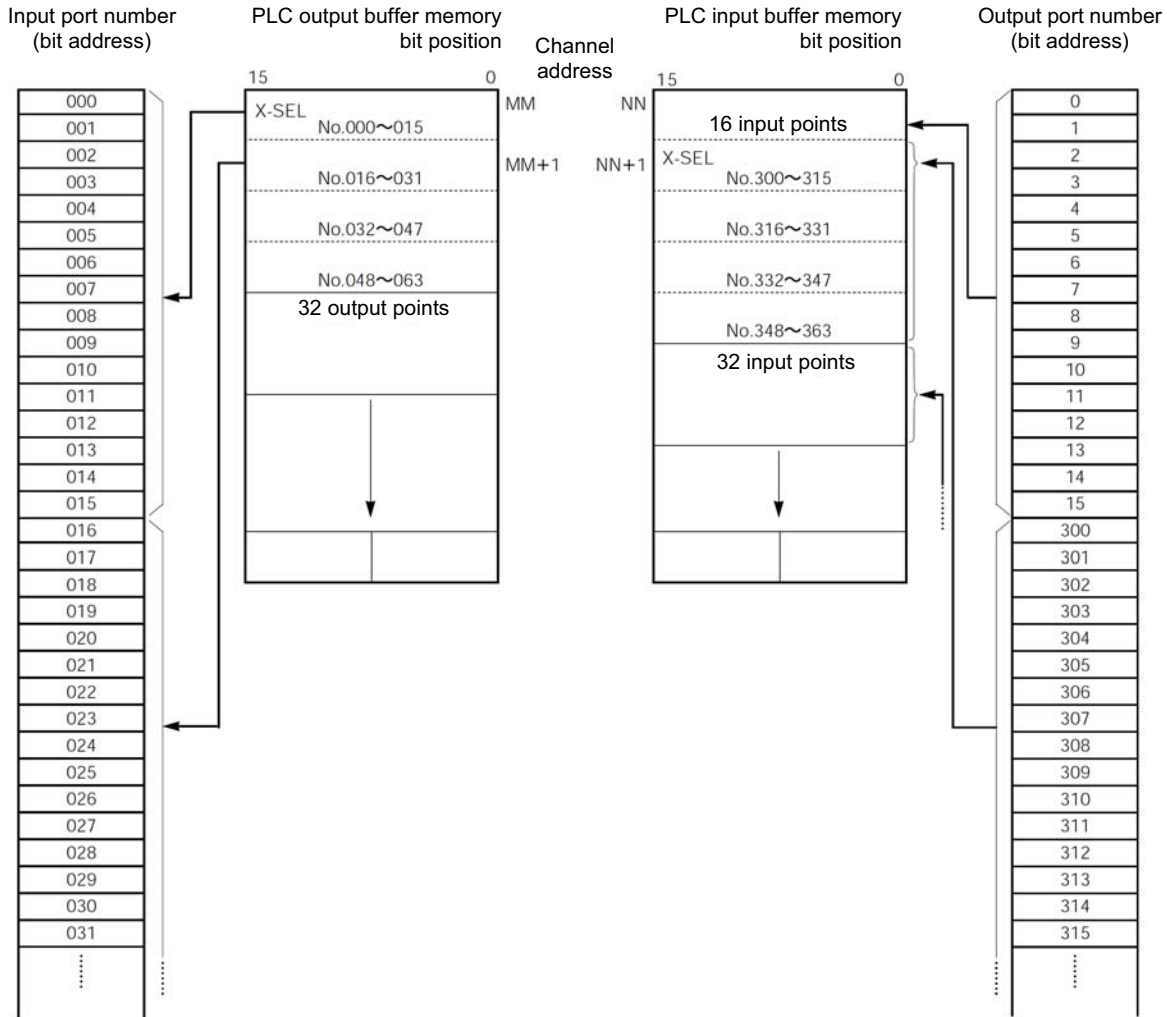

(Note) NN and MM are PLC channel addresses corresponding to node address nn. Since node addresses (nn, nn+1, nn+2, and so on) are occupied according to the numbers of I/O points used, pay attention to duplicate node address settings.

## 5) Description example of bit addresses --- Fuji Electric

The inputs and outputs of the X-SEL are respectively assigned I/O addresses (word addresses) as viewed from the PLC. The bit address description rules are specified below.

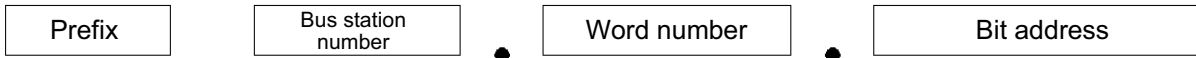

Prefix

- %IX ... Input bit address (address per bit)
- %IW ... Input word address (address per word)
- %QX ... Output bit address (address per bit)
- %QW ... Output word address (address per word)

Bus station number

This number indicates which of the units installed in the PLC is the ProfiBus-DP master unit. (Refer to the figure in 1).)

Word number

A sequential number specifying a word when the I/Os assigned to the master station are arranged in words.

Bit address

A sequential number specifying a bit when the I/Os assigned within each word above are arranged in bits.

## Reference

When bit addresses are set in the PLC, port numbers are assigned in units of 16 points, starting from the channels corresponding to the node address set by the DIP switches. (This does not apply when a configurator is used.)

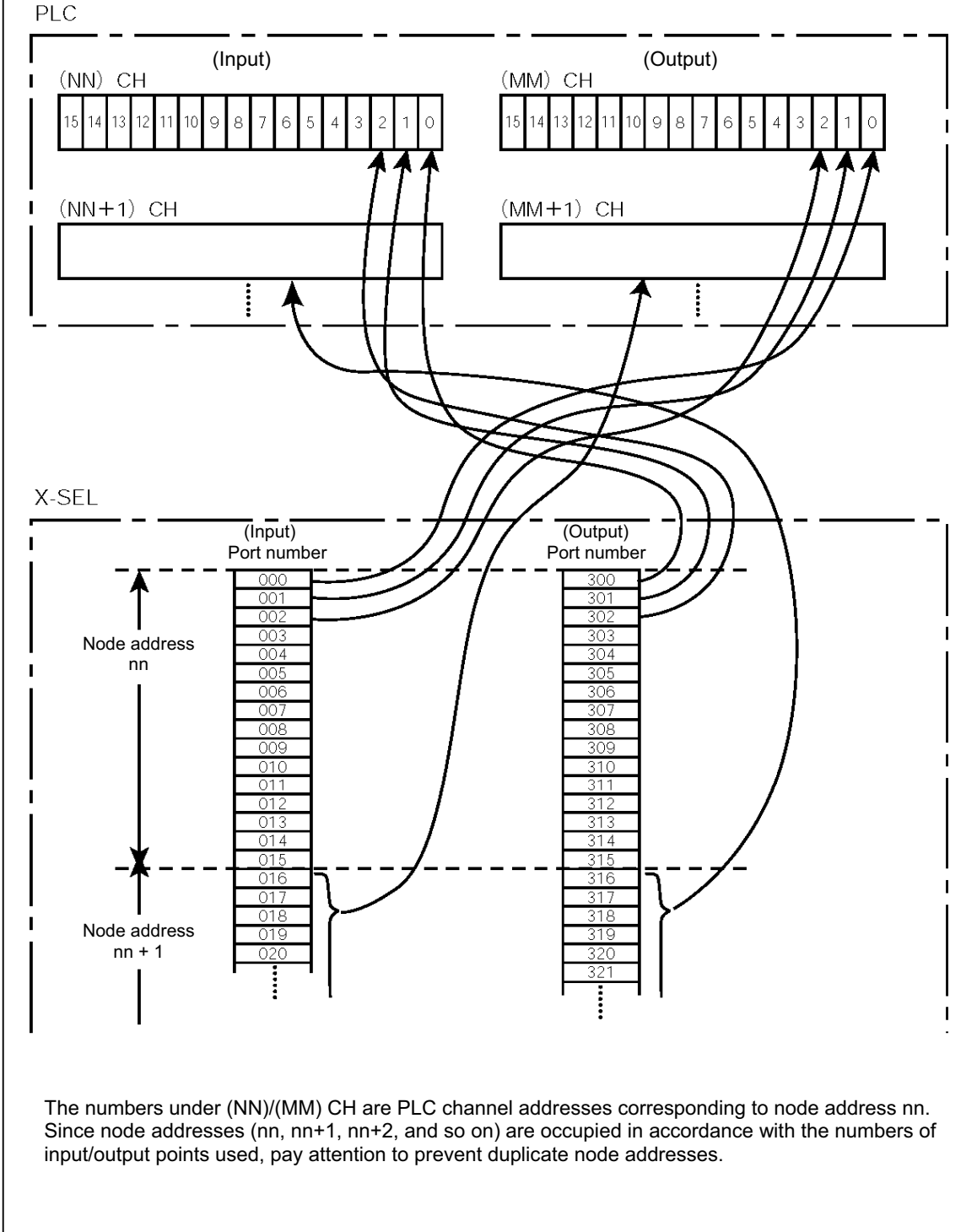

## 4. XSEL-R(A)/S(A)/R(A)X/S(A)X/R(A)XD/S(A)XD

The I/O data is handled as either bit data or word data. The fieldbus I/O data is mapped to input and output ports in the XSEL controller.

### 4.1 Model Numbers

The model code of each of XSEL-R(A)/S(A)/R(A)X/S(A)X/R(A)XD/S(A)XD applicable for PROFIBUS-DP is as shown below.

- |                   |                    |
|-------------------|--------------------|
| • XSEL-R-□-PR-□   | • XSEL-RA-□-PR-□   |
| • XSEL-S-□-PR-□   | • XSEL-SA-□-PR-□   |
| • XSEL-RX-□-PR-□  | • XSEL-RAX-□-PR-□  |
| • XSEL-SX-□-PR-□  | • XSEL-SAX-□-PR-□  |
| • XSEL-RXD-□-PR-□ | • XSEL-RAXD-□-PR-□ |
| • XSEL-SXD-□-PR-□ | • XSEL-SAXD-□-PR-□ |

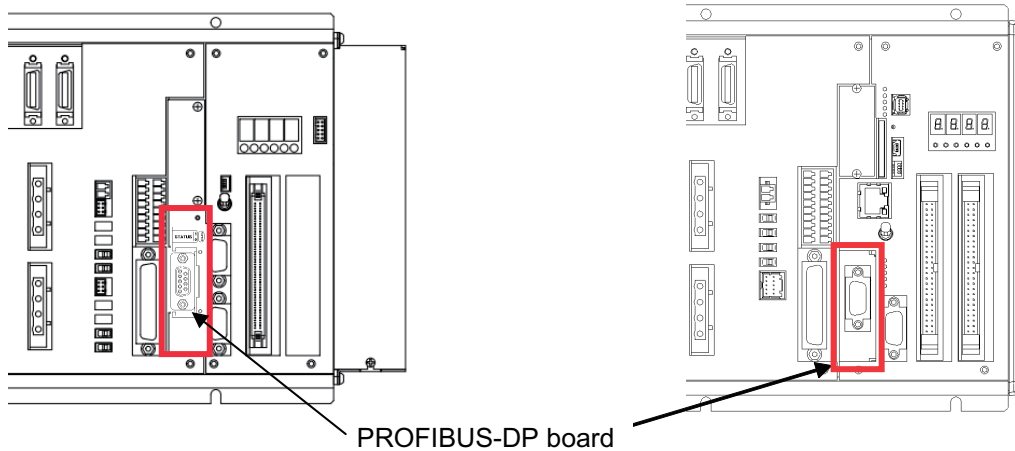

## 4.2 PROFIBUS-DP Interface

### (1) Name of each part

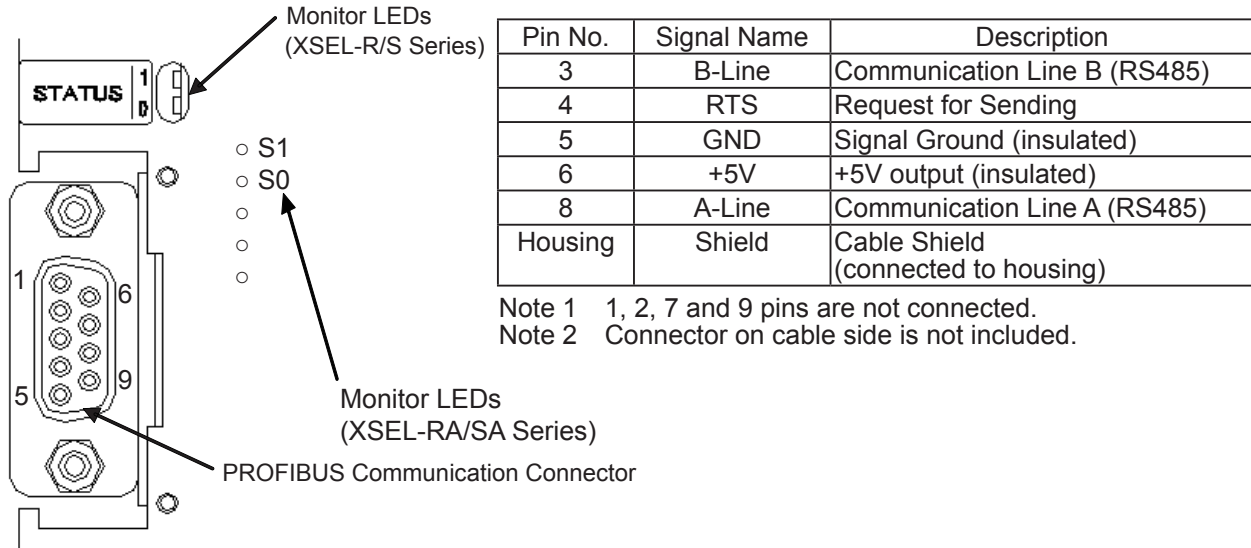

### (2) Monitor LED indications

The board operation status and network condition are obtained with the two LEDs located in the front of the communication board.

○: Illuminating ×: OFF ☆:Flashing (1Hz)

LED	Color	Indication Status	Indication Description (Detailed Explanation)
Operation Mode (S1)	Green	○	Online (Communication in normal condition)
		☆	Online (Cleared)
	Orange	☆ (1Hz)	Parameterizing data error
		☆ (2Hz)	Configuration error
	—	×	Online / No power supply confirmed
Status (S0)	Green	○	Initial condition
		☆	Initial condition (with network check event)
	Orange	○	Exception error
	—	×	No power supply confirmed / Initializing not executed

## 4.3 Parameter Settings

Set to the I/O parameters in the controller by using a teaching tool.

Place the controller's AUTO/MANU switch in the MANU position.

For the teaching tool version applicable for this controller check the instruction manual of each teaching tool.

\* The figure shown below is XSEL-R/S series. The setting should be the same for XSEL-RA/SA series.

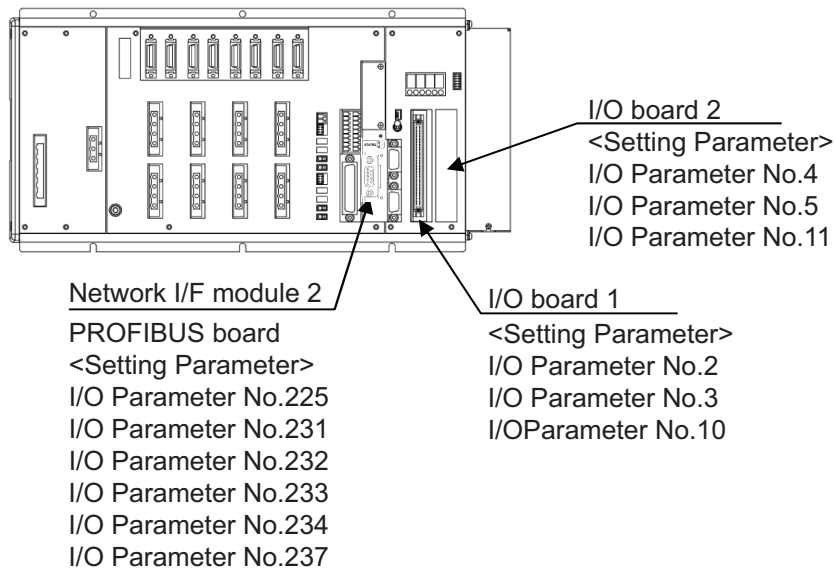

[1] Network Setting Check

Confirm that the 2nd digit of I/O Parameter No. 225 Network I/F Module Control setting is showing “3” (PROFIBUS).

No.	Parameter name	Default	Input Range	Unit	Remarks
225	Network I/F Module Control	3*	0*H to 3*H	—	bits 4-7 (2nd digit): Network I/F Module 2 types 0: Not Mounted 1: CC-Link 2: DeviceNet 3: PROFIBUS

[2] I/O Port Assignment Classification Setting

I/O Parameter No.1 Set I/O Port Assignment Classification.

No.	Parameter name	Default	Input Range	Unit	Remarks
1	I/O Port Assignment Classification Setting (Note)	1	0 to 1	—	0: Fixed Allocation 1: Automatic Allocation • Reference Priority of I/O Port Assignment when automatically assigned Port Number (No.0 to 299/No.300 to 599) 1) Network I/F Module 1 2) I/O slot 1 (I/O1) Mounting board 3) I/O slot 2 (I/O2) Mounting board * I/O slot 1 (I/O1) Assigned for the continuously mounted range from mounting board • Reference Priority of extension I/O ports at automatic assignment Port Number (No.1000 to 3999/No.4000 to 6999) 1) Network I/F Module 2 2) Expansion I/O unit 3) IA Net

**Note** If the automatic assignment is selected, the input port is assigned to an extension input port area (No.1000 to 3999). The output port is assigned to an extension output port area (No.4000 to 6999).  
 If the fixed assignment is selected, the user will manually assign the input either of the standard input port area (No.0 to 299) or extension input port area (No.1000 to 3999). For the output port, the user will manually assign the output to the standard output port area (No.300 to 599) or the extension output port area (No.4000 to 6999).

## [3] PROFIBUS Board Use Setting

Set "1" (Monitoring: use PROFIBUS board) to I/O Parameter No. 235.

No.	Parameter name	Default (Reference)	Input Range	Unit	Remarks
235	Network I/F Module 2 Error Monitoring	1	0 to 5	—	0:No Monitoring (Not to monitor condition of link to PLC (master)) 1:Monitoring

## [4] Node address setting

Set the node address to I/O Parameter No. 237

No.	Parameter name	Default (Reference)	Input Range	Unit	Remarks
237	Network I/F Module 2 Node Address	0	0 to 125	—	PROFIBUS node address range: 0 to 125

Note If a number out of the settable range is selected, "D75: Fieldbus Parameter Error" will occur.

## [5] Number of I/O Port Setting

Set the number of ports to be used for I/O Parameters No. 231 to 232.

Note Set a number that is a multiple of 8.

No.	Parameter name	Default (Reference)	Input Range	Unit	Remarks
231	No. of Network I/F Module 2 Remote Input Ports	0	0 to 256	—	8 port unit
232	No. of Network I/F Module 2 Remote Output Ports	0	0 to 256	—	8 port unit

[6] I/O Port Top Number Setting

Set the top port number of the port range used in I/O Parameters No. 233 to 234.

Note The port numbers assigned here are the starting input and output port numbers. Add the number of ports assigned in parameters 231 and 232 to determine the I/O range.

The values entered into these parameters must be evenly divisible by 8 (EX: 300).

No.	Parameter name	Default (Reference)	Input Range	Unit	Remarks
233	Extension Input Port Start No. at Network I/F Module 2 Fixed Assignment	-1	-1 to 299 1000 to 3999	—	0+ (Multiples of 8) or 1000+ (Multiples of 8) [Ineffective when -1 is selected]
234	Extension Output Port Start No. at Network I/F Module 2 Fixed Assignment	-1	-1 300 to 599 4000 to 6999	—	300+ (Multiples of 8) or 4000+ (Multiples of 8) [Ineffective when -1 is selected]

[7] Time Setting to Wait for PROFIBUS Communication Establishment

To I/O Parameter No. 120, set the maximum allowable time to establish PROFIBUS communication at the start. Change this setting when XSEL starts faster than the master unit, which results in a generation of D5D or A6B.

No.	Parameter name	Default (Reference)	Input Range	Unit	Remarks
120	Network attribute 1	640001H	0 to FFFFFFFFH	100ms	Bits 16 to 23: Value of Link Timeout at initializing (Example) The initial value 640001H is bit 16 to 23 = 64H = 100 (in 100ms unit) 100×100ms = 10sec It waits for 10sec at maximum from the startup for the communication establishment.

[8] Data Retaining Setting at PROFIBUS Communication Error

Set in I/O Parameter No. 121 whether to clear the input port data to 0 or to retain it at a communication error.

No.	Parameter name	Default (Reference)	Input Range	Unit	Remarks
121	Network attribute 2	0H	0 to FFFFFFFFH	—	Bits 8 to 15: Input port data selected at Network I/F Module 2 link error 0: Input port data clear 1: Input port data retained

## 4.4 Setting example

### (1) Example for when using only PROFIBUS

It is how to establish the setting when using PROFIBUS to 16 points of each input and output from the top of the standard I/O ports, and no other I/O port (for I/O board, etc.) is to be used.

\* The figure shown below is XSEL-R/S series. The setting should be the same for XSEL-RA/SA series.

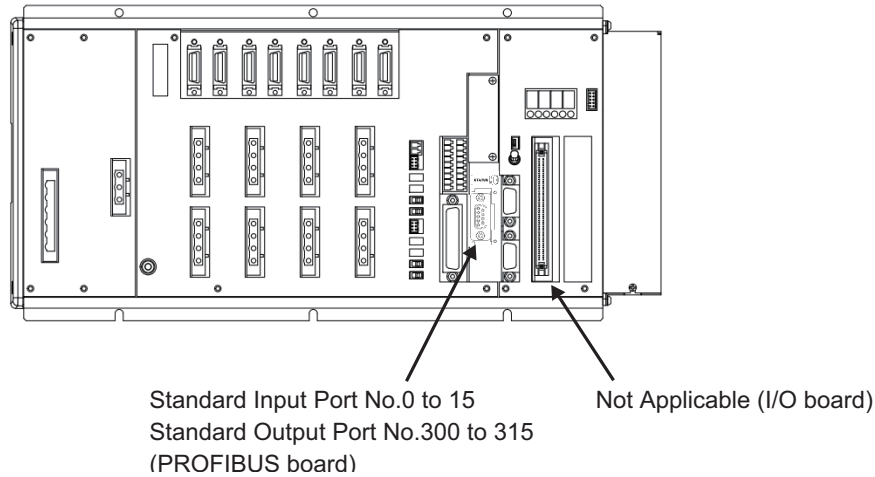

### • I/O Parameters

No.	Parameter name	Default (Reference)	Input Range	Unit	Remarks
1	I/O Port Allocation Type	1	0 to 1	0	0:Fixed Allocation 1:Automatic Allocation •Reference 1 Priority of I/O Port Assignment when automatically assigned Port Number (No.0 to 299/No.300 to 599) 1) Network I/F Module 1 2) I/O slot 1 (I/O1) Mounting board 3) I/O slot 2 (I/O2) Mounting board * I/O slot 1 (I/O1) Assigned for the continuously mounted range from mounting board •Reference 2 Priority of extension I/O ports at automatic assignment Port Number (No.1000 to 3999/No.4000 to 6999) 1) Network I/F Module 2 2) Expansion I/O unit 3) IA Net
2	Standard I/O Fix-Allocated Input Port Start No.	0	-1 to 599	-1	0+ (Multiples of 8) [Ineffective when -1 is selected]
3	Standard I/O Fix-Allocated Output Port Start No.	300	-1 to 599	-1	300+ (Multiples of 8) [Ineffective when -1 is selected]

No.	Parameter name	Default (Reference)	Input Range	Unit	Remarks
10	Standard I/O Error Monitoring (I/O1)	1	0 to 5	0	0:No Monitoring (Not to use I/O board) 1:Monitoring 2:Monitoring (Not to monitor 24V I/O power related error) 3:Monitoring (To monitor only 24V I/O power related error)
14	No. of Network I/F Module 1 Remote Input Ports	0	0 to 256	0	8 port unit
15	No. of Network I/F Module 1 Remote Output Ports	0	0 to 256	0	8 port unit
16	Input Port Start No. in Network I/F Module Fix-Allocated	-1	-1 to 599	-1	0+ (Multiples of 8) [Ineffective when -1 is selected]
17	Output Port Start No. in Network I/F Module Fix-Allocated	-1	-1 to 599	-1	300+ (Multiples of 8) [Ineffective when -1 is selected]
18	Network I/F Module 1 Error Monitoring	1	0 to 5	0	0:No Monitoring (Not to use Network I/F Module 1) 1:Monitoring
120	Network attribute 1	640001H	0 to FFFFFFFFH	Optional	Bits 16 to 23: Value of Link Timeout at initializing (Example) Default 64H = 10sec
121	Network attribute 2	0H	0 to FFFFFFFFH	Optional	Bits 8 to 15: Input port data selected at Network I/F Module 2 link error 0:Input port data clear 1:Input port data retained
225	Network I/F Module Control	3*	00H to 37H	30	Bits 0 to 3: Network I/F Module 1 type 0:Not Mounted 6:EtherCAT 7:EtherNet/IP Bits 4 to 7: Network I/F Module 2 type 0:Not Mounted 1:CC-Link 2:DeviceNet 3:PROFIBUS
231	No. of Network I/F Module 2 Remote Input Ports	0	0 to 256	16	8 port unit
232	No. of Network I/F Module 2 Remote Output Ports	0	0 to 256	16	8 port unit
233	Extension Input Port Start No. at Network I/F Module 2 Fixed Assignment	-1	-1 to 299 1000 to 3999	0	0+ (Multiples of 8) or 1000+ (Multiples of 8) [Ineffective when -1 is selected]
234	Extension Output Port Start No. at Network I/F Module 2 Fixed Assignment	-1	-1 300 to 599 4000 to 6999	300	300+ (Multiples of 8) or 4000+ (Multiples of 8) [Ineffective when -1 is selected]
235	Network I/F Module 2 Error Monitoring	1	0 to 5	1	0:No Monitoring (Not to monitor condition of link to PLC (master)) 1:Monitoring
237	Network I/F Module 2 Node Address	0	0 to 125	Optional	PROFIBUS node address range: 0 to 125

(2) Example for when using PROFIBUS and I/O Board 1 together

It is how to establish the setting when using PROFIBUS to 256 points of each input and output from the top of the extended I/O ports and assigning the I/O board (48 points for each input and output) to the standard I/O ports.

\* The figure shown below is XSEL-R/S series. The setting should be the same for XSEL-RA/SA series.

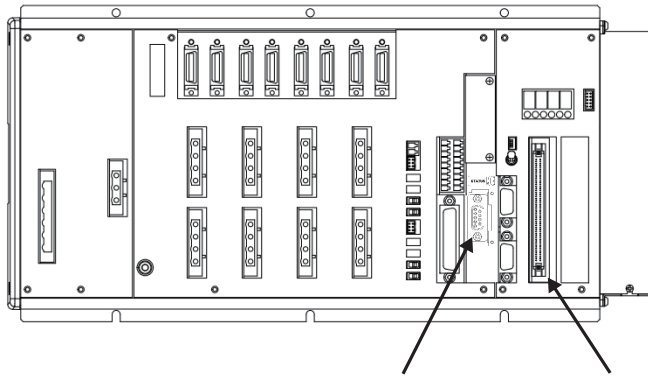

Extended Input Ports No.1000 to 1255  
 Extended Output Ports No.4000 to 4255  
 (PROFIBUS board)

Standard Input Port No.0 to 47  
 Standard Output Port No.300 to 347  
 (I/O board)

• I/O Parameters

No.	Parameter name	Default (Reference)	Input Range	Unit	Remarks
1	I/O Port Allocation Type	1	0 to 1	0	0:Fixed Allocation 1:Automatic Allocation •Reference 1 Priority of I/O Port Assignment when automatically assigned Port Number (No.0 to 299/No.300 to 599) 1) Network I/F Module 1 2) I/O slot 1 (I/O1) Mounting board 3) I/O slot 2 (I/O2) Mounting board * I/O slot 1 (I/O1) Assigned for the continuously mounted range from mounting board •Reference 2 Priority of extension I/O ports at automatic assignment Port Number (No.1000 to 3999/No.4000 to 6999) 1) Network I/F Module 2 2) Expansion I/O unit 3) IA Net
2	Standard I/O Fix-Allocated Input Port Start No.	0	-1 to 599	0	0+ (Multiples of 8) [Ineffective when -1 is selected]
3	Standard I/O Fix-Allocated Output Port Start No.	300	-1 to 599	300	300+ (Multiples of 8) [Ineffective when -1 is selected]

No.	Parameter name	Default (Reference)	Input Range	Unit	Remarks
10	Standard I/O Error Monitoring (I/O1)	1	0 to 5	1	0:No Monitoring (Not to use I/O board) 1:Monitoring 2:Monitoring (Not to monitor 24V I/O power related error) 3:Monitoring (To monitor only 24V I/O power related error)
14	No. of Network I/F Module 1 Remote Input Ports	0	0 to 256	0	8 port unit
15	No. of Network I/F Module 1 Remote Output Ports	0	0 to 256	0	8 port unit
16	Input Port Start No. in Network I/F Module Fix-Allocated	-1	-1 to 599	-1	0+ (Multiples of 8) [Ineffective when -1 is selected]
17	Output Port Start No. in Network I/F Module Fix-Allocated	-1	-1 to 599	-1	300+ (Multiples of 8) [Ineffective when -1 is selected]
18	Network I/F Module 1 Error Monitoring	1	0 to 5	0	0:No Monitoring (Not to use Network I/F Module 1) 1:Monitoring
120	Network attribute 1	640001H	0 to FFFFFFFFH	Optional	Bits 16 to 23: Value of Link Timeout at initializing (Example) Default 64H = 10sec
121	Network attribute 2	0H	0 to FFFFFFFFH	Optional	Bits 8 to 15: Input port data selected at Network I/F Module 2 link error 0:Input port data clear 1:Input port data retained
225	Network I/F Module Control	3*	00H to 37H	30	Bits 0 to 3: Network I/F Module 1 type 0:Not Mounted 6:EtherCAT 7:EtherNet/IP Bits 4 to 7: Network I/F Module 2 type 0:Not Mounted 1:CC-Link 2:DeviceNet 3:PROFIBUS
231	No. of Network I/F Module 2 Remote Input Ports	0	0 to 256	256	8 port unit
232	No. of Network I/F Module 2 Remote Output Ports	0	0 to 256	256	8 port unit
233	Extension Input Port Start No. at Network I/F Module 2 Fixed Assignment	-1	-1 to 299 1000 to 3999	1000	0+ (Multiples of 8) or 1000+ (Multiples of 8) [Ineffective when -1 is selected]
234	Extension Output Port Start No. at Network I/F Module 2 Fixed Assignment	-1	-1 300 to 599 4000 to 6999	4000	300+ (Multiples of 8) or 4000+ (Multiples of 8) [Ineffective when -1 is selected]
235	Network I/F Module 2 Error Monitoring	1	0 to 5	1	0:No Monitoring (Not to monitor condition of link to PLC (master)) 1:Monitoring
237	Network I/F Module 2 Node Address	0	0 to 125	Optional	PROFIBUS node address range: 0 to 125

(3) Example for when using PROFIBUS and I/O Board 1 together

It is how to establish the setting when using PROFIBUS to 192 points of each input and output from the top of the extended I/O ports and assigning the I/O board (48 points for each input and output) to the standard I/O ports.

\* The figure shown below is XSEL-R/S series. The setting should be the same for XSEL-RA/SA series.

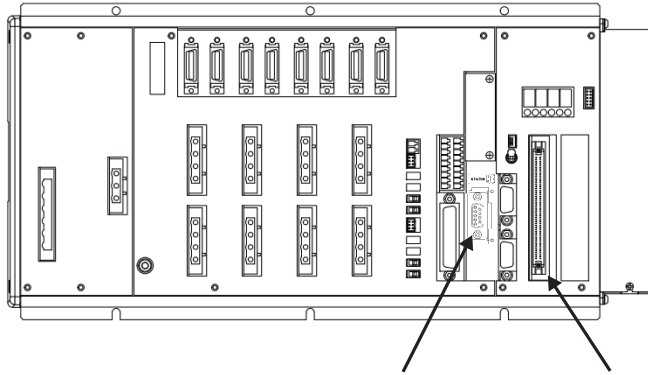

Standard Input Ports No.0 to 191  
Standard Output Ports No.300 to 491  
(PROFIBUS board)

Standard Input Port No.192 to 239  
Standard Output Port No.492 to 539  
(I/O board)

• I/O Parameters

No.	Parameter name	Default (Reference)	Input Range	Unit	Remarks
1	I/O Port Allocation Type	1	0 to 1	0	0:Fixed Allocation 1:Automatic Allocation •Reference 1 Priority of I/O Port Assignment when automatically assigned Port Number (No.0 to 299/No.300 to 599) 1) Network I/F Module 1 2) I/O slot 1 (I/O1) Mounting board 3) I/O slot 2 (I/O2) Mounting board * I/O slot 1 (I/O1) Assigned for the continuously mounted range from mounting board •Reference 2 Priority of extension I/O ports at automatic assignment Port Number (No.1000 to 3999/No.4000 to 6999) 1) Network I/F Module 2 2) Expansion I/O unit 3) IA Net
2	Standard I/O Fix-Allocated Input Port Start No.	0	-1 to 599	192	0+ (Multiples of 8) [Ineffective when -1 is selected]
3	Standard I/O Fix-Allocated Output Port Start No.	300	-1 to 599	492	300+ (Multiples of 8) [Ineffective when -1 is selected]

No.	Parameter name	Default (Reference)	Input Range	Unit	Remarks
10	Standard I/O Error Monitoring (I/O1)	1	0 to 5	1	0:No Monitoring (Not to use I/O board) 1:Monitoring 2:Monitoring (Not to monitor 24V I/O power related error) 3:Monitoring (To monitor only 24V I/O power related error)
14	No. of Network I/F Module 1 Remote Input Ports	0	0 to 256	0	8 port unit
15	No. of Network I/F Module 1 Remote Output Ports	0	0 to 256	0	8 port unit
16	Input Port Start No. in Network I/F Module Fix-Allocated	-1	-1 to 599	-1	0+ (Multiples of 8) [Ineffective when -1 is selected]
17	Output Port Start No. in Network I/F Module Fix-Allocated	-1	-1 to 599	-1	300+ (Multiples of 8) [Ineffective when -1 is selected]
18	Network I/F Module 1 Error Monitoring	1	0 to 5	0	0:No Monitoring (Not to use Network I/F Module 1) 1:Monitoring
120	Network attribute 1	640001H	0 to FFFFFFFFH	Optional	Bits 16 to 23: Value of Link Timeout at initializing (Example) Default 64H = 10sec
121	Network attribute 2	0H	0 to FFFFFFFFH	Optional	Bits 8 to 15: Input port data selected at Network I/F Module 2 link error 0:Input port data clear 1:Input port data retained
225	Network I/F Module Control	3*	00H to 37H	30	Bits 0 to 3: Network I/F Module 1 type 0:Not Mounted 6:EtherCAT 7:EtherNet/IP Bits 4 to 7: Network I/F Module 2 type 0:Not Mounted 1:CC-Link 2:DeviceNet 3:PROFIBUS
231	No. of Network I/F Module 2 Remote Input Ports	0	0 to 256	192	8 port unit
232	No. of Network I/F Module 2 Remote Output Ports	0	0 to 256	192	8 port unit
233	Extension Input Port Start No. at Network I/F Module 2 Fixed Assignment	-1	-1 to 299 1000 to 3999	0	0+ (Multiples of 8) or 1000+ (Multiples of 8) [Ineffective when -1 is selected]
234	Extension Output Port Start No. at Network I/F Module 2 Fixed Assignment	-1	-1 300 to 599 4000 to 6999	300	300+ (Multiples of 8) or 4000+ (Multiples of 8) [Ineffective when -1 is selected]
235	Network I/F Module 2 Error Monitoring	1	0 to 5	1	0:No Monitoring (Not to monitor condition of link to PLC (master)) 1:Monitoring
237	Network I/F Module 2 Node Address	0	0 to 125	Optional	PROFIBUS node address range: 0 to 125

## 4.5 Standard I/O Ports of XSEL Controller

For the standard I/O ports of XSEL controller, it is possible to change the specified functions except for the general-purposed I/O with the I/O parameters. [Refer to the instruction manual for the XSEL-R/S/RX/SX/RXD/SXD controller or XSEL-RA/SA/RAX/SAX/RAXD/SAXD controller for more information.]

- Settings of Standard I/O Ports at Delivery

Input Port		Output Port		
Port No.	Function	Port No.	Function	
000	Program Start	300	Alarm Output	
001	Universal Output	301	Ready Output	
002	Universal Output	302	Emergency Stop Output	
003	Universal Output	303	Universal Output	
004	Universal Input	304	Universal Output	
005	Universal Input	305	Universal Output	
006	Universal Input	306	Universal Output	
007	Program Specification	(LSB) Startup program to be indicated with binary	307	Universal Output
008	Program Specification		308	Universal Output
009	Program Specification		309	Universal Output
010	Program Specification		310	Universal Output
011	Program Specification		311	Universal Output
012	Program Specification		312	Universal Output
013	Program Specification		(MSB)	313
014	Universal Input	314	Universal Output	
015	Universal Input	315	Universal Output	
⋮	⋮	⋮	⋮	

Note The number of standard I/O ports is;

- Input 000 to 299 (MAX 300 points)
- Output 300 to 599 (MAX 300 points)

Be careful of the number of I/O ports when using PROFIBUS and PIO together.

## Reference

When bit addresses are set in the PLC, port numbers are assigned in units of 16 points, starting from the channels corresponding to the node address set by the parameters.  
(This does not apply when a configurator is used.)

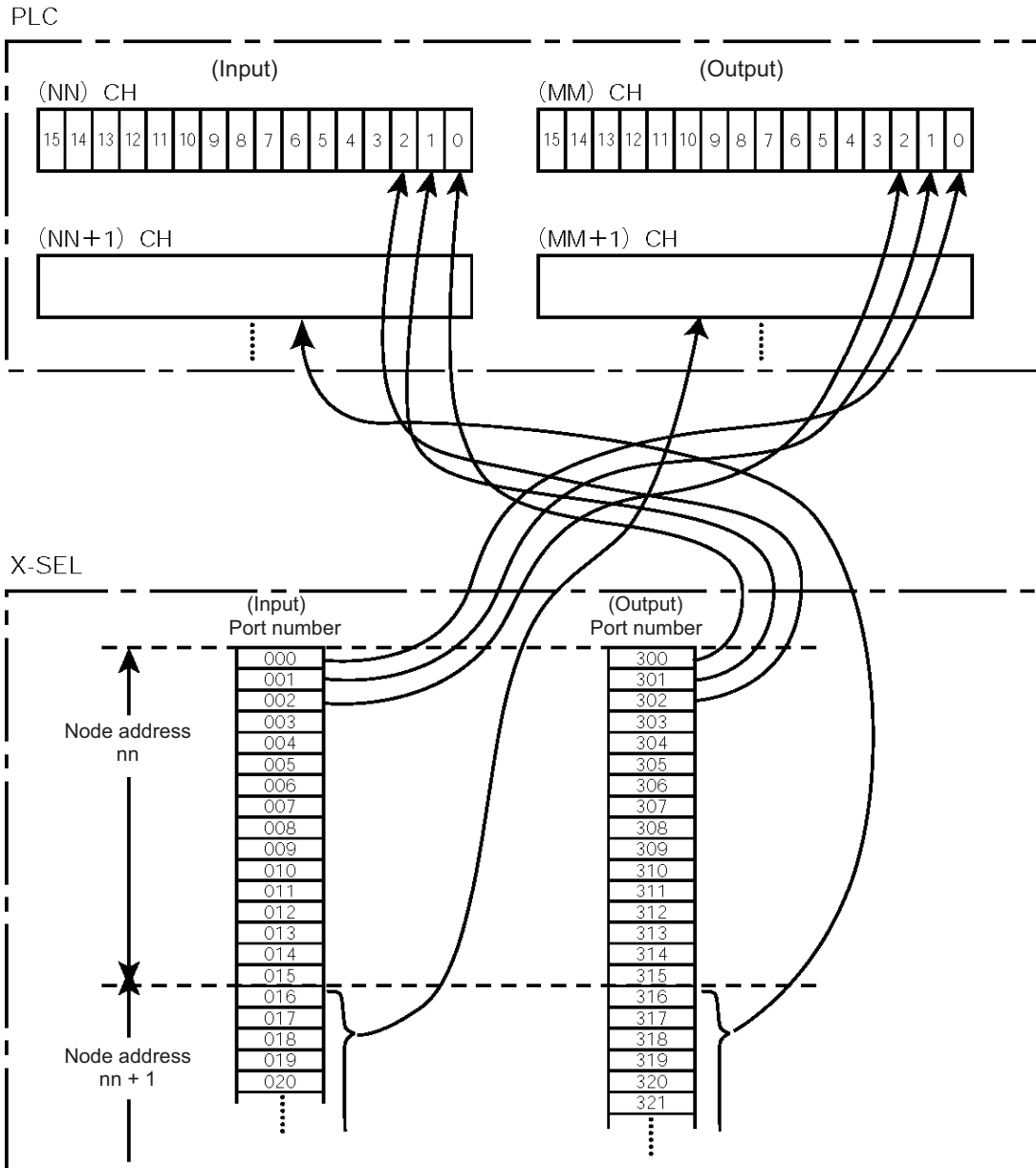

The numbers under (NN)/(MM) CH are PLC channel addresses corresponding to node address nn. Since node addresses (nn, nn+1, nn+2, and so on) are occupied in accordance with the numbers of input/output points used, pay attention to prevent duplicate node addresses.

## 4.6 Troubleshooting

1) In case it is not possible to connect the network, check the current condition on the display of monitoring LEDs of PROFIBUS Board. [Refer to Section 4.2]  
 Check the settings of the XSEL controller and the settings of the master unit referring to the instruction manuals of the master unit.

2) When an alarm is issued, an alarm code gets output to the panel window of the XSEL controller.

(1) Find the alarm code that you see on the window from the alarm code list shown below.  
 Deal with it based on the description for the alarm code in question.

(2) In case the alarm code is not found in the following list, search in the alarm contents list contained in XSEL Controller Instruction Manual. Deal with it based on the description for the alarm code in question.

Alarm Code (Fieldbus related items are chosen below)

No.	Error name	Contents and Treatment
678	Extended I/O Port Assignment Parameter Error	There is an error in a parameter related to the extended I/O port assignment.
679	Extended I/O Port Assignment Number Overflow Error	The number of extended I/O port assignment exceeded the specification range.
67A	Extended I/O Port Duplicated Assignment Error	Extended I/O port assignment has duplicated.
D56	Fieldbus error (MinACK Timeout)	An error was detected in the communication board. Check the condition of PLC, and reboot the XSEL controller unless there is an error. If the same error occurs again, please contact us.
D59	Fieldbus error (DPRAM writing and reading)	The writing and reading error was detected in the internal memory. XSEL Controller reboot the controller. If the same error occurs again, please contact us.
D5A	Fieldbus error (TOGGLE Timeout)	A communication board error was detected. XSEL Controller reboot the controller. If the same error occurs again, please contact us.
D5B	Fieldbus error (Access right retry over)	A communication board error was detected. XSEL Controller reboot the controller. If the same error occurs again, please contact us.
D5D	Fieldbus error (FBRS link error)	This occurs when the network connection is not established. 1) Check the station number, the parameters for communication speed and parameters on PLC side. 2) It is concerned the startup of XSEL is faster than that of PLC. Change the settings in I/O Parameter No. 120. [Refer to Section 4.3 (7) for the details.]
D5E	Fieldbus error (Mail BOX response)	A communication board error was detected. Reboot the XSEL controller. If the same error occurs again, please contact us.
D5F	Network I/F Module Class Mismatch Error	The setting of I/O Parameter No. 225 Network I/F Module Class does not match with that of the communication board currently mounted to XSEL. Check the contents of the settings in I/O Parameter No. 225, and in case no doubt is found, please contact us.
D75	Fieldbus Parameter Error	There is an error in a parameter. Check I/O Parameter No. 226 to 227 and 237 to 238. Example) • A node address out of the range was set. • A baud rate out of the range is set.

No.	Error name	Contents and Treatment
D77	Fieldbus error (Exception)	A communication board error was detected. Reboot the XSEL controller. If the same error occurs again, please contact us.
E1F	I/O Assignment Parameter Error	It is a parameter setting error. Check to see that a number out of the I/O port number (except for -1) is not set to I/O Parameters No. 2 to 9, a number out of indication is not input to I/O port start number, or a number out of indication is not input to I/O Parameters No. 14 to 17. [Refer to XSEL Controller Instruction Manual.]
E20	I/O Duplication Assignment Error	I/O assignment is duplicated. Check to see that a number out of the I/O port number (except for -1) is not set to I/O Parameters No. 2 to 9, a number out of indication is not input to I/O port start number, or a number out of indication is not input to I/O Parameters No. 14 to 17. [Refer to XSEL Controller Instruction Manual.] Check the number of the ports that I/O boards are mounted.
E21	I/O Assignment Number Overflow Error	I/O assignment has exceeded the specified range. Check to see that a number out of the I/O port number (except for -1) is not set to I/O Parameters No. 2 to 9, a number out of indication is not input to I/O port start number, or a number out of indication is not input to I/O Parameters No. 14 to 17. [Refer to XSEL Controller Instruction Manual.] Check the number of the ports that I/O boards are mounted.
E8F	Fieldbus logic error	It is a logic error at the Fieldbus initializing.

## 5. MSEL

MSEL, which are applicable for PROFIBUS-DP, deal the I/O data as the bit data or word data, and operate while reflecting the data.

### 5.1 Model Numbers

The model codes are as shown below:

- MSEL-PC-□-□-□-□-PR
- MSEL-PG□-□-□-□-PR

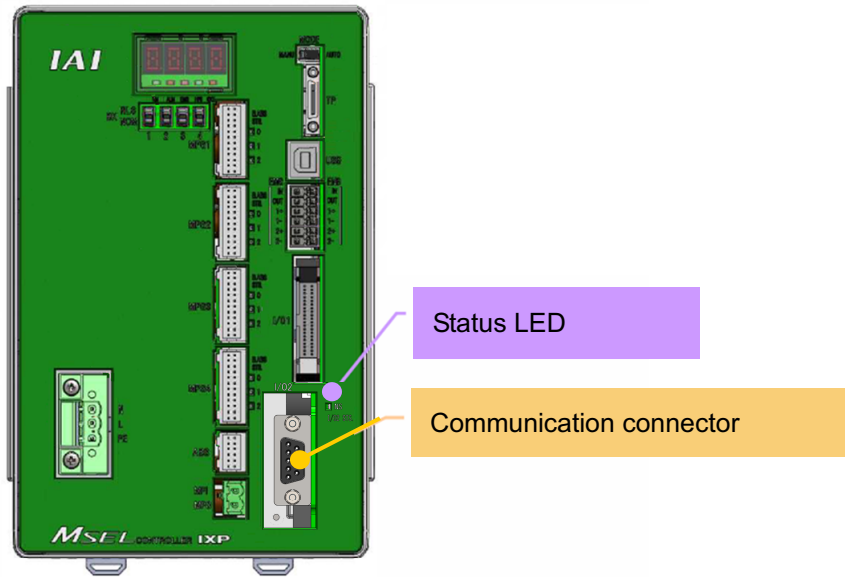

## 5.2 PROFIBUS-DP Interface

### (1) Communication Connector

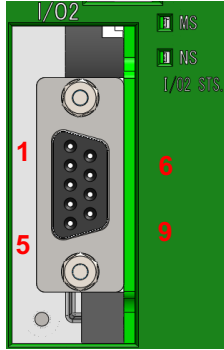

Pin No.	Signal Name	Description
3	B-Line	Communication Line B (RS485)
4	RTS	Request for Sending
5	GND	Signal Ground (insulated)
6	+5V	+5V output (insulated)
8	A-Line	Communication Line A (RS485)
Housing	Shield	Cable Shield (FG inside controller and the connection)

Note 1 1, 2, 7 and 9 pins are not connected.  
 Note 2 Connector on cable side is not included.

### (2) Monitor LED indications

The board operation status and network condition are obtained with the two LEDs located in the front of the communication board.



○ : Illuminating    × : OFF    ☆ : Flashing

LED	Color	Illumination Status	Indication Description (Detailed Explanation)
NS	green	○	Online (Communication in normal condition)
		☆	Online (Cleared)
	orange	☆	Parameterizing data error, Configuration error
	-	×	Online/No power supply confirmed
MS	green	○	Initial condition
		☆	Initial condition (with network check event)
	orange	○	Exception error
	-	×	No power supply confirmed/Initializing not executed

## 5.3 Parameter Settings

Set to the I/O parameters in the controller by using a teaching tool.

Set the mode switchover switch on the front panel to MANU side.

The teaching tool version applicable for MSEL is as shown below:

- XSEL PC software : V10.00.09.00 to
- TB-01 : V1.02 to

### [1] Network Setting Check

Confirm that the I/O Parameter No. 225 Network I/F Module Control setting is showing “3” (PROFIBUS).  
(The setting of this parameter is to be established before delivery)

No.	Parameter name	Default	Input Range	Unit	Remarks
225	Extension I/O Control	3	3 <sub>H</sub>	-	Bits 0-3(First digit): I/O3 module type 0: Not Mounted 1:CC-Link 2:DeviceNet 3:PROFIBUS

### [2] PROFIBUS-DP Board Use Setting

Have I/O Parameter No. 18 set to “1” (Monitor: use PROFIBUS-DP board).

No.	Parameter name	Default (Reference)	Input Range	Unit	Remarks
18	I/O2 Error Monitoring	1	0 to 5	-	0: No Monitoring (Not to use PROFIBUS-DP board) 1: Monitoring

### [3] Node address setting

Have the node address set in I/O Parameter No. 226.

No.	Parameter name	Default (Reference)	Input Range	Unit	Remarks
226	I/O2 Fieldbus Node Address	0	0 to 64	-	PROFIBUS-DP node address range: 0 to 125

Note If a number out of the settable range is selected, “D75: Fieldbus Parameter Error” will occur.

[4] Communication Speed Setting

It is not necessary to establish the setting for PROFIBUS-DP as it automatically identifies the baud rate.

[5] Number of I/O Port Setting

Have the port numbers to be used set in I/O Parameter No. 14 and 15.

Note Set a number that is a multiple of 8.

No.	Parameter name	Default (Reference)	Input Range	Unit	Remarks
14	I/O2 Fieldbus Remote Input Ports	0	0 to 240	-	8 port unit
15	I/O2 Fieldbus Remote Output Ports	0	0 to 240	-	8 port unit

[6] I/O Port Top Number Setting

Have the top port number in the port range to be used set in I/O Parameter No. 16 and 17.

Note The values entered into these parameters must be evenly divisible by 8.

No.	Parameter name	Default (Reference)	Input Range	Unit	Remarks
16	I/O2 Fixed Assignment Input Port Start Number	-1	-1 48 to 287	-	48+(Multiples of 8) [Ineffective when -1 is selected]
17	I/O2 Fixed Assignment Output Port Start Number	-1	-1 348 to 587	-	348+(Multiples of 8) [Ineffective when -1 is selected]

[7] Time Setting to Wait for PROFIBUS-DP Communication Establishment

In I/O Parameter No. 121, set the time until check is to be held to see if the PROFIBUS-DP communication is established at the startup. Change the parameter in case D5D or A6B error occurs due to a faster startup of MSEL than the master unit.

No.	Parameter name	Default (Reference)	Input Range	Unit	Remarks
121	Network Attribute 2	C80000 <sub>H</sub>	0 to FFFFFFF <sub>H</sub>	100ms	Bits 16 to 27: Value of Link Timeout at initializing of the Fieldbus (Example) The initial value C80000 <sub>H</sub> is bit 16 to 27 = C8 <sub>H</sub> = 200 (in 100ms unit) 200×100ms = 20sec Check in 20sec after startup

[8] Data Retaining Setting at PROFIBUS-DP Communication Error

Have the setting established in I/O Parameter No. 120 whether to clear the input port data at 0 or to remain the data when a communication error is occurred.

No.	Parameter name	Default (Reference)	Input Range	Unit	Remarks
120	Network Attribute 1	640001 <sub>H</sub>	0 to FFFFFFFF <sub>H</sub>	-	Bits 28 to 31: Input port data selected at I/O2 Fieldbus link error 0: Input port data clear 1: Input port data retained

## 5.4 Setting Example

(1) Example for when using only PROFIBUS-DP (I/O2)

It is how to establish the setting when using PROFIBUS-DP (I/O2) to 16 ports of each input and output from the top of the standard I/O ports, and no other I/O port (for I/O board, etc.) is to be used.

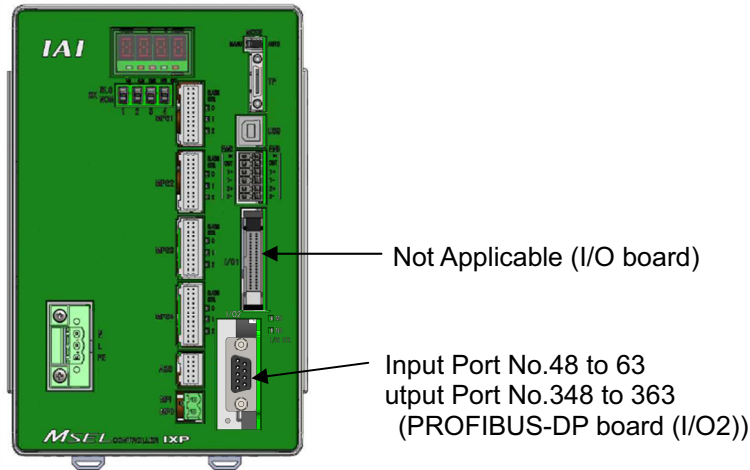

### • I/O Parameters

No.	Parameter name	Default (Reference)	Input Range	Unit	Remarks
2	I/O1 Fixed Assignment Input Port Start Number	0	-1 to 599	-1	0+(Multiples of 8) [Ineffective when -1 is selected]
3	I/O1 Fixed Assignment Output Port Start Number	300	-1 to 599	-1	300+(Multiples of 8) [Ineffective when -1 is selected]
10	I/O1 Error Monitoring	1	0 to 5	0	0: No Monitoring (Not to use I/O board) 1: Monitoring 2: Monitoring (Not to monitor 24V I/O power related error) 3: Monitoring (To monitor only 24V I/O power related error)
14	I/O2 Fieldbus Remote Input Ports	0	0 to 256	16	8 port unit
15	I/O2 Fieldbus Remote Output Ports	0	0 to 256	16	8 port unit
16	I/O2 Fixed Assignment Input Port Start Number	-1	-1 to 599	48	48+(Multiples of 8) [Ineffective when -1 is selected]
17	I/O2 Fixed Assignment Output Port Start Number	-1	-1 to 599	348	348+(Multiples of 8) [Ineffective when -1 is selected]
18	I/O2 Error Monitoring	1	0 to 5	1	0: No Monitoring (Not to use Network I/F Module 1) 1: Monitoring
120	Network Attribute 1	640001 <sub>H</sub>	0 to FFFFFFFF <sub>H</sub>	Optional	Bits 28 to 31: Input port data selected at I/O2 Fieldbus link error 0: Input port data clear 1: Input port data retained

No.	Parameter name	Default (Reference)	Input Range	Unit	Remarks
121	Network Attribute 2	C80000 <sub>H</sub>	0 to FFFFFFF <sub>H</sub>	100ms	Bits 16 to 27: Value of Link Timeout at initializing of the Fieldbus (Example) The initial value C80000 <sub>H</sub> is bit 16 to 27 = C8 <sub>H</sub> = 200 (in 100ms unit) 200×100ms = 20sec Check in 20sec after startup
225	Extension I/O Control	3	3 <sub>H</sub>	3 (Confirmation)	Bits 0-3(First digit): I/O3 module type Bits 4-7(2nd digit): I/O3 module type 0: Not Mounted 1:CC-Link 2:DeviceNet 3:PROFIBUS
226	I/O2 Fieldbus Node Address	0	0 to 125	Optional	PROFIBUS-DP node address range: 0 to 125

- (2) Example for when using PROFIBUS-DP and I/O Board 1 together  
 This is a setting to use I/O board (16 points each for input and output) and PROFIBUS-DP on I/O port (I/O2) at 240 points of ports each for input and output on the ports.

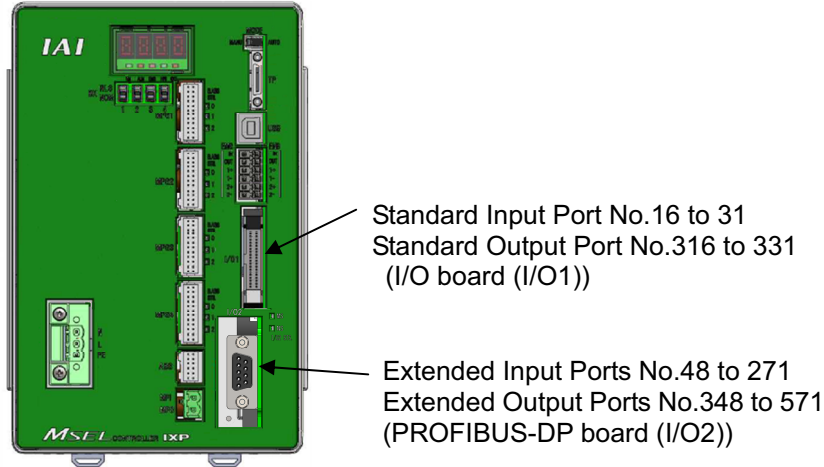

● I/O Parameters

No.	Parameter name	Default (Reference)	Input Range	Unit	Remarks
2	I/O1 Fixed Assignment Input Port Start Number	0	-1 to 599	16	0+(Multiples of 8) [Ineffective when -1 is selected]
3	I/O1 Fixed Assignment Output Port Start Number	300	-1 to 599	316	300+(Multiples of 8) [Ineffective when -1 is selected]
10	I/O1 Error Monitoring	1	0 to 5	1	0: No Monitoring (Not to use I/O board) 1: Monitoring 2: Monitoring (Not to monitor 24V I/O power related error) 3: Monitoring (To monitor only 24V I/O power related error)
14	I/O2 Fieldbus Remote Input Ports	0	0 to 256	224	8 port unit
15	I/O2 Fieldbus Remote Output Ports	0	0 to 256	224	8 port unit
16	I/O2 Fixed Assignment Input Port Start Number	-1	-1 to 599	48	48+(Multiples of 8) [Ineffective when -1 is selected]
17	I/O2 Fixed Assignment Output Port Start Number	-1	-1 to 599	348	348+(Multiples of 8) [Ineffective when -1 is selected]
18	I/O2 Error Monitoring	1	0 to 5	1	0: No Monitoring (Not to use Network I/F Module 1) 1: Monitoring
120	Network Attribute 1	640001 <sub>H</sub>	0 to FFFFFFFF <sub>H</sub>	Optional	Bits 28 to 31: Input port data selected at I/O2 Fieldbus link error 0: Input port data clear 1: Input port data retained

No.	Parameter name	Default (Reference)	Input Range	Unit	Remarks
121	Network Attribute 2	C80000 <sub>H</sub>	0 to FFFFFFFF <sub>H</sub>	100ms	Bits 16 to 27: Value of Link Timeout at initializing of the Fieldbus (Example) The initial value C80000 <sub>H</sub> is bit 16 to 27 = C8 <sub>H</sub> = 200 (in 100ms unit) 200×100ms = 20sec Check in 20sec after startup
225	Extension I/O Control	3	3 <sub>H</sub>	3 (Confirmation)	Bits 0-3(First digit): I/O3 module type Bits 4-7(2nd digit): I/O3 module type 0: Not Mounted 1:CC-Link 2:DeviceNet 3:PROFIBUS
226	I/O2 Fieldbus Node Address	0	0 to 125	Optional	PROFIBUS-DP node address range: 0 to 125

## 5.5 I/O Ports of the MSEL

For the I/O ports, it is possible to change the specified functions except for the general-purposed I/O with the I/O parameters. [Refer to the instruction manual for the MSEL for more information.]

● I/O Port Setting at Delivery

	Port No.	Function		Port No.	Function
Internal DI	000	For future expansion	Internal DO	300	ALM (LED on the front panel)
	001			301	RDY (LED on the front panel)
	002			302	EMG (LED on the front panel)
	003			303	For future expansion
	004			304	HPS (LED on the front panel)
	005			305	For future expansion
	006			306	
	007			307	
	008			308	
	009			309	
	010			310	
	011			311	
	012			312	
	013			313	
	014			314	
015	315				
External DI	016	Program start	External DO	316	Alarm output
	017	General-purpose input		317	READY output
	018			318	Emergency-stop output
	019			General-purpose output	
	020				319
	021				320
	022				321
	023	Program number specification (LSB)			322
	024	Program number specification			323
	025	Program number specification			324
	026	Program number specification		325	
	027	Program number specification		326	
	028	Program number specification		327	
029	Program number specification (MSB)	328			
030	General-purpose input	329			
031		330			
Internal DI	032	For future expansion	Internal DO	331	
	033			332	7-segment user display digit
	034			333	7-segment user display digit
	035			For future expansion	
	036				334
	037				335
	038			336	
	039			337	7-segment display refresh
	040			338	7-segment user/system alternate
	041			339	7-segment user display specification
	042			340	DT0 (7-segment user display bit)
	043			341	DT1 (7-segment user display bit)
	044			342	DT2 (7-segment user display bit)
	045			343	DT3 (7-segment user display bit)
	046			344	DT4 (7-segment user display bit)
	047			345	DT5 (7-segment user display bit)
				346	DT6 (7-segment user display bit)
	347	For future expansion			
External DI	048 to 287	For PROFIBUS-DP of General-purpose input	External DO	348 to 587	For PROFIBUS-DP of General-purpose output

Reference

When bit addresses are set in the parameter, port numbers are assigned in units of 16 points, starting from the channels corresponding to the node address set by the DIP switches. (This does not apply when a configurator is used.)

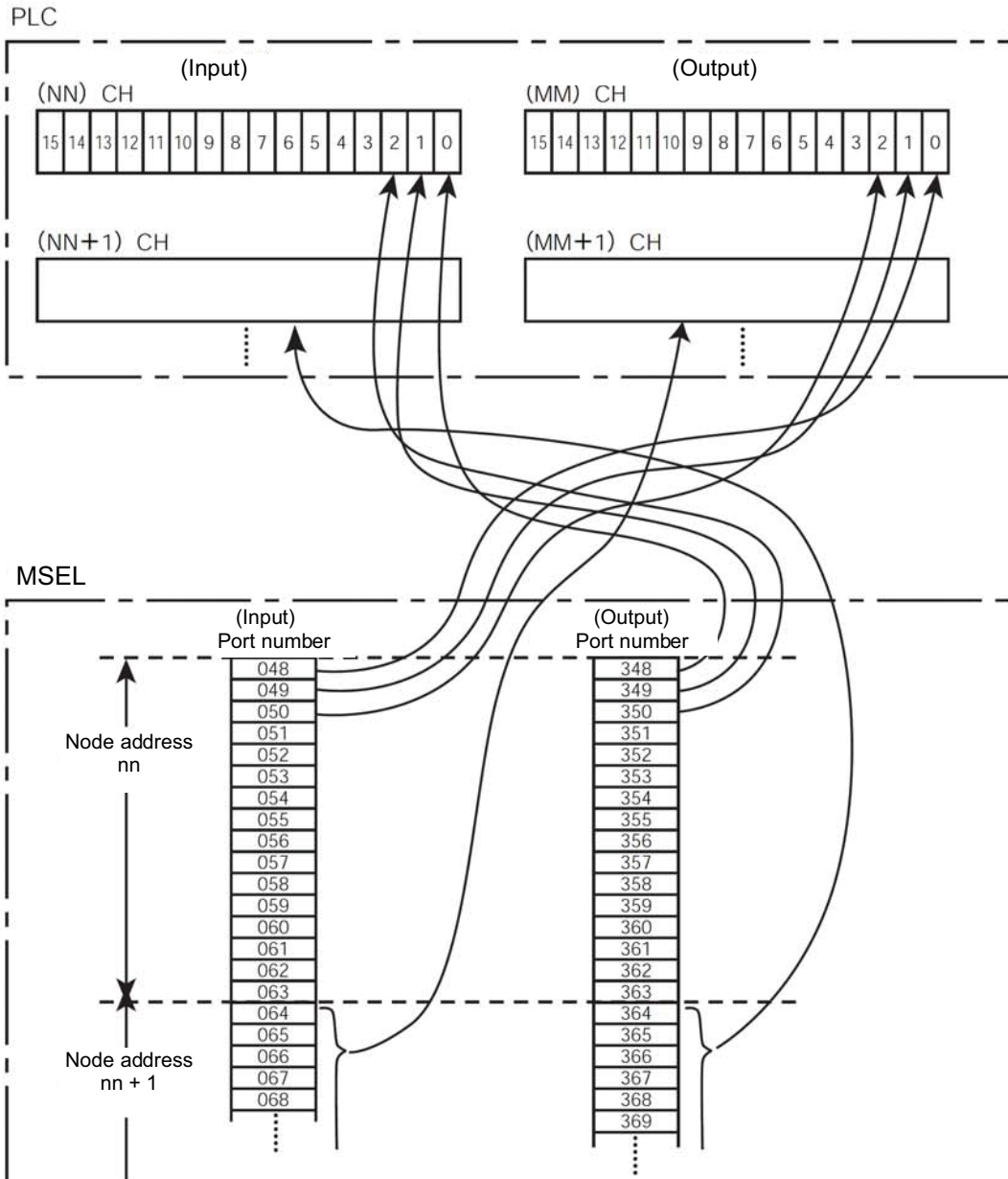

The numbers under (NN)/(MM) CH are PLC channel addresses corresponding to node address nn. Since node addresses (nn, nn+1, nn+2, and so on) are occupied in accordance with the numbers of input/output points used, pay attention to prevent duplicate node addresses.

## 5.6 Precautions

The configuration data format is applicable for the both formats of standard / special identification. However, it is necessary to make the PROFIBUS use I/O size of MSEL corresponded to the size of the configuration data.

- Standard Identification Format

Normal (compact) ID format (one byte)								
Byte (octet) 1:	7	6	5	4	3	2	1 0	Bit
			0	1				ID defines <u>only</u> Input configuration
			1	0				ID defines <u>only</u> Output configuration
			1	1				ID defines Input and Output configuration
			0	0				Special ID format (use decoding table for special format)
								Number of configured data (inputs/outputs):
								00 <sub>dec</sub> (0 <sub>hex</sub> ) = 1 Unit (Byte/Word)
								15 <sub>dec</sub> (F <sub>hex</sub> ) = 16 Units (Byte/Word)
			1					Unit = Word
			0					Unit = Byte
			1					Consistency over the whole configured data block (Module)
			0					Consistency over one Unit (Byte/ Word)

- Special Identification Format

Special (extended) ID format								
Structure for one special configuration ID								
Special Configuration ID	Previous ID	ID Header	Length OUTPUT	Length INPUT	Vendor spec. Data	next ID		
		x x 0 0 x x x x	only if outputs	only if inputs	(optional)			
Decoding table for special format								
Byte (octet) 1:	7	6	5	4	3	2	1 0	Bit
Configuration ID header			0	0				Special ID format (use decoding table for special format)
								Number of vendor specific config ID data at the end
								00 <sub>dec</sub> (0 <sub>hex</sub> ) = no vendor specific data
								14 <sub>dec</sub> (E <sub>hex</sub> ) = 14 vendor specific data
								15 <sub>dec</sub> (F <sub>hex</sub> ) = no vendor specific data
			0	0				Empty module, module has no input or output configuration
			0	1				One length byte for Inputs follows
			1	0				One length byte for Outputs follows
			1	1				One length byte for <u>each</u> Outputs and Inputs follows
following Byte(s)	7	6	5	4	3	2	1 0	Bit
one length byte for outputs followed by the length byte for inputs, if both are defined.								Number of configured data (inputs/outputs):
								00 <sub>dec</sub> (0 <sub>hex</sub> ) = 1 Unit (Byte/Word)
								63 <sub>dec</sub> (3F <sub>hex</sub> ) = 64 Unit (Byte/Word)
			1					Unit = Word
			0					Unit = Byte
			1					Consistency over the whole configured data block (Module)
			0					Consistency over one Unit (Byte/ Word)
following Byte(s)	7	6	5	4	3	2	1 0	Bit
Vendor spec. data								Vendor specific config ID, defined by the device vendor
								00 - 255 <sub>dec</sub> (00 - FF <sub>hex</sub> )

## 5.7 Troubleshooting

- 1) In case it is not possible to connect the network, check the current condition on the display of monitoring LEDs of PROFIBUS-DP Board. [Refer to Section 5.2]  
Check the settings of the MSEL and the settings of the master unit referring to the instruction manuals of the master unit.
- 2) When an alarm is issued, an alarm code gets output to the panel window of the XSEL controller.
  - (1) Find the alarm code that you see on the window from the alarm code list shown below.  
Deal with it based on the description for the alarm code in question.
  - (2) In case the alarm code is not found in the following list, search in the alarm contents list contained in MSEL Instruction Manual. Deal with it based on the description for the alarm code in question.

Alarm Code (Fieldbus related items are chosen below)

No.	Error name	Contents and Treatment
A6B	Fieldbus error (FBRS link error)	MSEL starts up faster than the host (master unit). Change the setting in I/O Parameter No. 121 Bit 16 to 23 to have the time extended before timeout.
D56	Fieldbus error (MinACK Timeout)	A communication error was detected. Check the condition of PLC, and reboot the MSEL unless there is an error. If the same error occurs again, please contact us.
D59	Fieldbus error (DPRAM writing and reading)	The writing and reading error was detected in the internal memory. MSEL reboot the controller. If the same error occurs again, please contact us.
D5A	Fieldbus error (TOGGLE Timeout)	A communication error was detected. MSEL reboot the controller. If the same error occurs again, please contact us.
D5B	Fieldbus error (Access right retry over)	A communication board error was detected. MSEL reboot the controller. If the same error occurs again, please contact us.
D5D	Fieldbus error (FBRS link error)	This occurs when the network connection is not established. 1) Check the station number, the parameters for communication speed and parameters on higher-order side. 2) It is concerned the startup of MSEL is faster than that of PLC. Change the settings in I/O Parameter No. 121. [Refer to Section 5.3 [7] for the details.]
D5E	Fieldbus error (Mail BOX response)	A communication error was detected. Reboot the MSEL. If the same error occurs again, please contact us.
D5F	Network I/F Module Class Mismatch Error	The setting of I/O Parameter No. 225 Network I/F Module Class does not match with that of the communication board mounted. Check the contents of the settings in I/O Parameter No. 225, and in case no doubt is found, please contact us.
D75	Fieldbus Parameter Error	There is an error in a parameter. Check I/O Parameter No. 226 and 238. Example) • A node address out of the range was set. • A communication speed out of the range is set.
D76	Fieldbus Module Unmounted Error	PROFIBUS-DP board is not mounted.
D77	Fieldbus error (Exception)	A communication board error was detected. Reboot the MSEL. If the same error occurs again, please contact us.
E1F	I/O Assignment Parameter Error	It is a parameter setting error. Check to see that a number out of the I/O port number (except for -1) is not set to I/O Parameters No. 2 to 9, a number out of indication is not input to I/O port start number, or a number out of indication is not input to I/O Parameters No. 14 to 17. [Refer to MSEL Instruction Manual.]

No.	Error name	Contents and Treatment
E20	I/O Duplication Assignment Error	I/O assignment is duplicated. Check to see that a number out of the I/O port number (except for -1) is not set to I/O Parameters No. 2 to 9, a number out of indication is not input to I/O port start number, or a number out of indication is not input to I/O Parameters No. 14 to 17. [Refer to MSEL Instruction Manual.] Check the number of the ports that I/O boards are mounted.
E21	I/O Assignment Number Overflow Error	I/O assignment has exceeded the specified range. Check to see that a number out of the I/O port number (except for -1) is not set to I/O Parameters No. 2 to 9, a number out of indication is not input to I/O port start number, or a number out of indication is not input to I/O Parameters No. 14 to 17. [Refer to MSEL Instruction Manual.] Check the number of the ports that I/O boards are mounted.
E8F	Fieldbus logic error	It is a logic error at the Fieldbus initializing.

## 6. Tabletop Robot TTA

Tabletop Robot TTA, which are applicable for PROFIBUS-DP, deal the I/O data as the bit data or word data, and operate while reflecting the data.

### 6.1 Model Numbers

The model codes are as shown below:

- TTA-A□-I-□-□-□-□-PR
- TTA-A□-I-□-□-□-□-□-PR
- TTA-A□-I-□-□-□-□-PR-PR

6. Tabletop Robot TTA

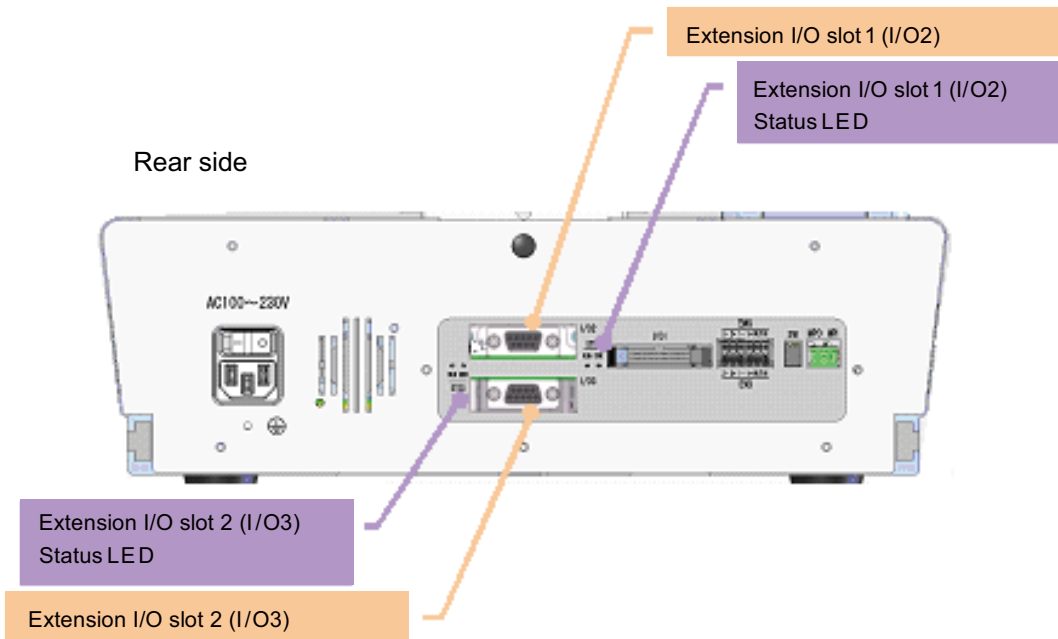

## 6.2 PROFIBUS-DP Interface

Two pieces of PROFIBUS-DP board can be mounted at the maximum.

### (1) Name of Each Part

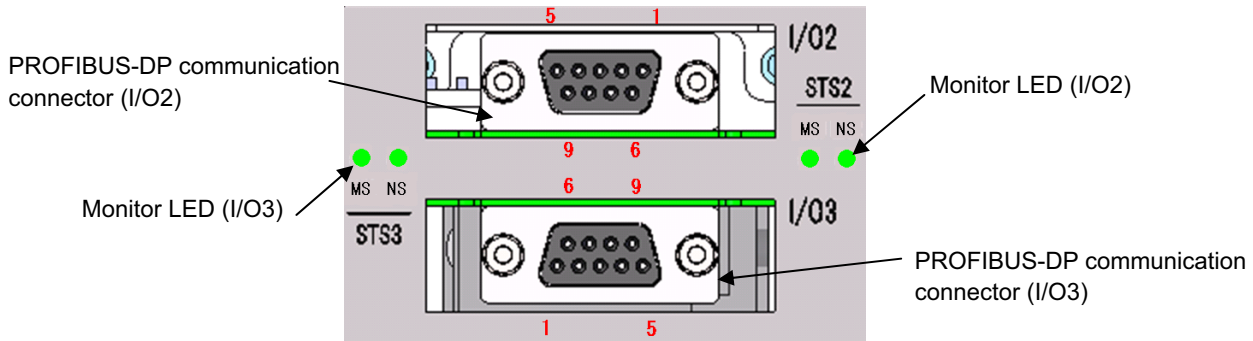

Pin No.	Signal Name	Description
3	B-Line	Communication Line B (RS485)
4	RTS	Request for Sending
5	GND	Signal Ground (insulated)
6	+5V	+5V output (insulated)
8	A-Line	Communication Line A (RS485)
Housing	Shield	Cable Shield (FG inside controller and the connection)

Note 1 1, 2, 7 and 9 pins are not connected.

Note 2 Connector on cable side is not included.

### (2) Monitor LED indications

The board operation status and network condition are obtained with the two LEDs located in the front of the communication board.

○ : Illuminating    × : OFF    ☆ : Flashing

LED	Color	Illumination Status	Indication Description (Detailed Explanation)
NS	green	○	Online (Communication in normal condition)
		☆	Online (Cleared)
	orange	☆	Parameterizing data error, Configuration error
	-	×	Online/No power supply confirmed
MS	green	○	Initial condition
		☆	Initial condition (with network check event)
	orange	○	Exception error
	-	×	No power supply confirmed/Initializing not executed

## 6.3 Parameter Settings

Set to the I/O parameters in the controller by using a teaching tool.

Note The setting parameter number will differ depending on the slot number (I/O2 or I/O3) mounting PROFIBUS-DP.

Check on which slot the PROFIBUS-DP board is mounted in your TTA before starting the setting work.

Set the mode switchover switch on the front panel to MANU side.

The teaching tool version applicable for TTA is as shown below:

- XSEL PC software : V10.00.00.00 to
- SEL-T/TD : V1.17 to
- IA-T-X : V1.52 to

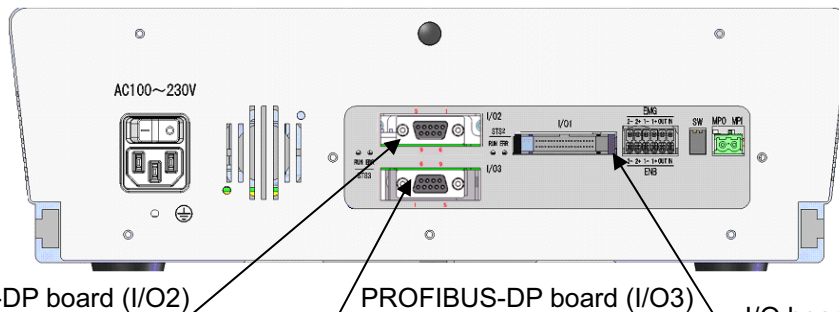

PROFIBUS-DP board (I/O2)

< Setting Parameter >

- I/O Parameter No.14
- I/O Parameter No.15
- I/O Parameter No.16
- I/O Parameter No.17
- I/O Parameter No.18
- I/O Parameter No.225
- I/O Parameter No.226
- I/O Parameter No.227

PROFIBUS-DP board (I/O3)

< Setting Parameter >

- I/O Parameter No.225
- I/O Parameter No.231
- I/O Parameter No.232
- I/O Parameter No.233
- I/O Parameter No.234
- I/O Parameter No.235
- I/O Parameter No.237
- I/O Parameter No.238

I/O board 1 (I/O1)

< Setting Parameter >

- I/O Parameter No.2
- I/O Parameter No.3
- I/O Parameter No.10

[1] Network Setting Check

Confirm that the I/O Parameter No. 225 Network I/F Module Control setting is showing “3” (PROFIBUS-DP). (The setting of this parameter is to be established before delivery)

Note The digit to check will differ depending on the position to mount PROFIBUS-DP (Mounted on I/O2: 1<sup>st</sup> digit, mounted on I/O3: 2<sup>nd</sup> digit)

No.	Parameter name	Default	Input Range	Unit	Remarks
225	Extension I/O Control	*3 3* 33	03 <sub>H</sub> to 33 <sub>H</sub>	-	Bits 0-3(First digit): I/O3 module type Bits 4-7(2nd digit): I/O3 module type 0: Not Mounted 1:CC-Link 2:DeviceNet 3:PROFIBUS

[2] PROFIBUS-DP Board Use Setting

Have I/O Parameter No. 18 and 235 set to “1” (Monitor: use PROFIBUS-DP board) in accordance with the position to mount PROFIBUS-DP board.

No.	Parameter name	Default (Reference)	Input Range	Unit	Remarks
18	I/O2 Error Monitoring	1	0 to 5	-	0: No Monitoring (Not to use PROFIBUS-DP board) 1: Monitoring
235	I/O3 Error Monitoring	1	0 to 5	-	0: No Monitoring (Not to use PROFIBUS-DP board) 1: Monitoring

[3] Node address setting

Have the node address set in I/O Parameter No. 226 and 237 in accordance with the position to mount PROFIBUS-DP board.

No.	Parameter name	Default (Reference)	Input Range	Unit	Remarks
226	I/O2 Fieldbus Node Address	0	0 to 64	-	PROFIBUS-DP node address range: 1 to 125
237	I/O3 Fieldbus Node Address	0	0 to 64	-	PROFIBUS-DP node address range: 1 to 125

Note If a number out of the settable range is selected, “D75: Fieldbus Parameter Error” will occur.

[4] Communication Speed Setting

It is not necessary to establish the setting for PROFIBUS-DP as it automatically identifies the baud rate.

[5] Number of I/O Port Setting

Have the port numbers to be used set in I/O Parameter No. 14, 15, 231 and 232 in accordance with the position to mount PROFIBUS-DP board.

Note Set a number that is a multiple of 8.

No.	Parameter name	Default (Reference)	Input Range	Unit	Remarks
14	I/O2 Fieldbus Remote Input Ports	0	0 to 240	-	8 port unit
15	I/O2 Fieldbus Remote Output Ports	0	0 to 240	-	8 port unit
231	I/O3 Fieldbus Remote Input Ports	0	0 to 240	-	8 port unit
232	I/O3 Fieldbus Remote Output Ports	0	0 to 240	-	8 port unit



**Caution**

The available number of ports to be used is 240 at the maximum no matter if the number of mounted PROFIBUS-DP board is 1 piece or 2 pieces.

[6] I/O Port Top Number Setting

Have the top port number in the port range to be used set in I/O Parameter No. 16, 17, 233 and 234 in accordance with the position to mount PROFIBUS-DP board.

Note The values entered into these parameters must be evenly divisible by 8.

No.	Parameter name	Default (Reference)	Input Range	Unit	Remarks
16	I/O2 Fixed Assignment Input Port Start Number	-1	-1 48 to 287	-	48+(Multiples of 8) [Ineffective when -1 is selected]
17	I/O2 Fixed Assignment Output Port Start Number	-1	-1 348 to 587	-	348+(Multiples of 8) [Ineffective when -1 is selected]
233	I/O3 Fixed Assignment Input Port Start Number	-1	-1 48 to 287	-	48+(Multiples of 8) [Ineffective when -1 is selected]
234	I/O3 Fixed Assignment Output Port Start Number	-1	-1 348 to 587	-	348+(Multiples of 8) [Ineffective when -1 is selected]

[7] Time Setting to Wait for PROFIBUS-DP Communication Establishment

In I/O Parameter No. 121, set the time until check is to be held to see if the PROFIBUS-DP communication is established at the startup. Change the parameter in case D5D or A6B error occurs due to a faster startup of TTA than the master unit.

No.	Parameter name	Default (Reference)	Input Range	Unit	Remarks
121	Network Attribute 2	C80000 <sub>H</sub>	0 to FFFFFFFF <sub>H</sub>	100ms	Bits 16 to 27: Value of Link Timeout at initializing of the Fieldbus (Example) The initial value C80000 <sub>H</sub> is bit 16 to 27 = C8 <sub>H</sub> = 200 (in 100ms unit) 200×100ms = 20sec Check in 20sec after startup

[8] Data Retaining Setting at PROFIBUS-DP Communication Error

Have the setting established in I/O Parameter No. 121 whether to clear the input port data at 0 or to remain the data when a communication error is occurred in accordance with the position to mount PROFIBUS-DP.

No.	Parameter name	Default (Reference)	Input Range	Unit	Remarks
120	Network Attribute 1	640001 <sub>H</sub>	0 to FFFFFFFF <sub>H</sub>	-	Bits 28 to 31: Input port data selected at I/O2 Fieldbus link error 0: Input port data clear 1: Input port data retained
121	Network Attribute 2	C80000 <sub>H</sub>	0 to FFFFFFFF <sub>H</sub>	-	Bits 8 to 11: Input port data selected at I/O3 Fieldbus link error 0: Input port data clear 1: Input port data retained

## 6.4 Setting Example

### (1) Example for when using only PROFIBUS-DP (I/O2)

It is how to establish the setting when using PROFIBUS-DP (I/O2) to 16 ports of each input and output from the top of the standard I/O ports, and no other I/O port (for I/O board, etc.) is to be used.

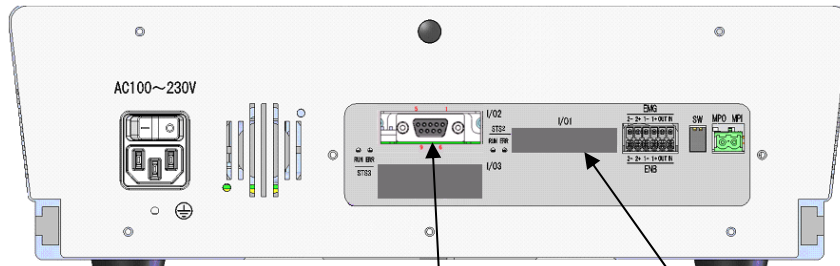

Input Port No.48 to 63  
Output Port No.348 to 363  
(PROFIBUS-DP board (I/O2))

Not Applicable (I/O board)

### ● I/O Parameters

No.	Parameter name	Default (Reference)	Input Range	Unit	Remarks
2	I/O1 Fixed Assignment Input Port Start Number	0	-1 to 599	-1	0+(Multiples of 8) [Ineffective when -1 is selected]
3	I/O1 Fixed Assignment Output Port Start Number	300	-1 to 599	-1	300+(Multiples of 8) [Ineffective when -1 is selected]
10	I/O1 Error Monitoring	1	0 to 5	0	0: No Monitoring (Not to use I/O board) 1: Monitoring 2: Monitoring (Not to monitor 24V I/O power related error) 3: Monitoring (To monitor only 24V I/O power related error)
14	I/O2 Fieldbus Remote Input Ports	0	0 to 256	16	8 port unit
15	I/O2 Fieldbus Remote Output Ports	0	0 to 256	16	8 port unit
16	I/O2 Fixed Assignment Input Port Start Number	-1	-1 to 599	48	48+(Multiples of 8) [Ineffective when -1 is selected]
17	I/O2 Fixed Assignment Output Port Start Number	-1	-1 to 599	348	348+(Multiples of 8) [Ineffective when -1 is selected]
18	I/O2 Error Monitoring	1	0 to 5	1	0: No Monitoring (Not to use Network I/F Module 1) 1: Monitoring
120	Network Attribute 1	640001 <sub>H</sub>	0 to FFFFFFFF <sub>H</sub>	Optional	Bits 16 to 27: Value of Link Timeout at initializing of the Fieldbus Bits 28 to 31: Input port data selected at I/O2 Fieldbus link error 0: Input port data clear 1: Input port data retained

No.	Parameter name	Default (Reference)	Input Range	Unit	Remarks
121	Network Attribute 2	0 <sub>H</sub>	0 to FFFFFFFF <sub>H</sub>	Optional	Bits 8 to 11: Input port data selected at I/O3 Fieldbus link error 0: Input port data clear 1: Input port data retained
225	Extension I/O Control	03	03 <sub>H</sub> to 33 <sub>H</sub>	-	Bits 0-3(First digit): I/O3 module type Bits 4-7(2nd digit): I/O3 module type 0: Not Mounted 1:CC-Link 2:DeviceNet 3:PROFIBUS
226	I/O2 Fieldbus Node Address	0	0 to 125	Optional	PROFIBUS-DP node address range: 1 to 125
235	I/O3 Error Monitoring	1	0 to 5	-	0: No Monitoring (Not to use Network I/F Module 1) 1: Monitoring

- (2) Example for when using PROFIBUS-DP and I/O Board 1 together  
 This is a setting to use I/O board (16 points each for input and output) and PROFIBUS-DP on I/O port (I/O2) at 240 points of ports each for input and output on the ports.

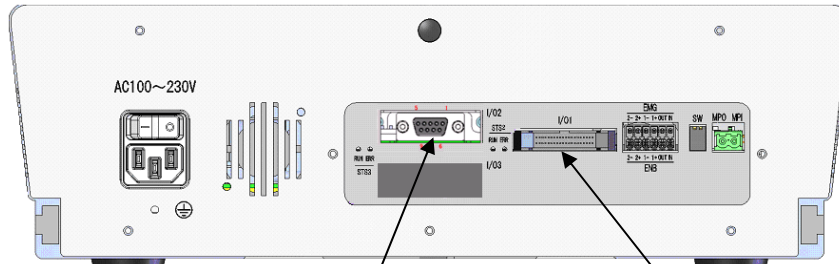

Extended Input Ports No.48 to 271  
 Extended Output Ports No.348 to 571  
 (PROFIBUS-DP board (I/O2))

Standard Input Port No.16 to 31  
 Standard Output Port No.316 to 331  
 (I/O board (I/O1))

● I/O Parameters

No.	Parameter name	Default (Reference)	Input Range	Unit	Remarks
2	I/O1 Fixed Assignment Input Port Start Number	0	-1 to 599	0	0+(Multiples of 8) [Ineffective when -1 is selected]
3	I/O1 Fixed Assignment Output Port Start Number	300	-1 to 599	300	300+(Multiples of 8) [Ineffective when -1 is selected]
10	I/O1 Error Monitoring	1	0 to 5	1	0: No Monitoring (Not to use I/O board) 1: Monitoring 2: Monitoring (Not to monitor 24V I/O power related error) 3: Monitoring (To monitor only 24V I/O power related error)
14	I/O2 Fieldbus Remote Input Ports	0	0 to 256	224	8 port unit
15	I/O2 Fieldbus Remote Output Ports	0	0 to 256	224	8 port unit
16	I/O2 Fixed Assignment Input Port Start Number	-1	-1 to 599	48	48+(Multiples of 8) [Ineffective when -1 is selected]
17	I/O2 Fixed Assignment Output Port Start Number	-1	-1 to 599	348	348+(Multiples of 8) [Ineffective when -1 is selected]
18	I/O2 Error Monitoring	1	0 to 5	1	0: No Monitoring (Not to use Network I/F Module 1) 1: Monitoring
120	Network Attribute 1	640001 <sub>H</sub>	0 to FFFFFFFF <sub>H</sub>	Optional	Bits 16 to 27: Value of Link Timeout at initializing of the Fieldbus Bits 28 to 31: Input port data selected at I/O2 Fieldbus link error 0: Input port data clear 1: Input port data retained

No.	Parameter name	Default (Reference)	Input Range	Unit	Remarks
121	Network Attribute 2	0 <sub>H</sub>	0 to FFFFFFFF <sub>H</sub>	Optional	Bits 8 to 11: Input port data selected at I/O3 Fieldbus link error 0: Input port data clear 1: Input port data retained
225	Extension I/O Control	03	03 <sub>H</sub> to 33 <sub>H</sub>	-	Bits 0-3(First digit): I/O3 module type Bits 4-7(2nd digit): I/O3 module type 0: Not Mounted 1:CC-Link 2:DeviceNet 3:PROFIBUS
226	I/O2 Fieldbus Node Address	0	0 to 125	Optional	PROFIBUS-DP node address range: 1 to 125
235	I/O3 Error Monitoring	1	0 to 5	-	0: No Monitoring (Not to use Network I/F Module 1) 1: Monitoring

- (3) Example for when using PROFIBUS-DP (I/O2 and I/O3) together  
 This is a setting to mount two pieces of PROFIBUS-DP and use 120 points on each port.

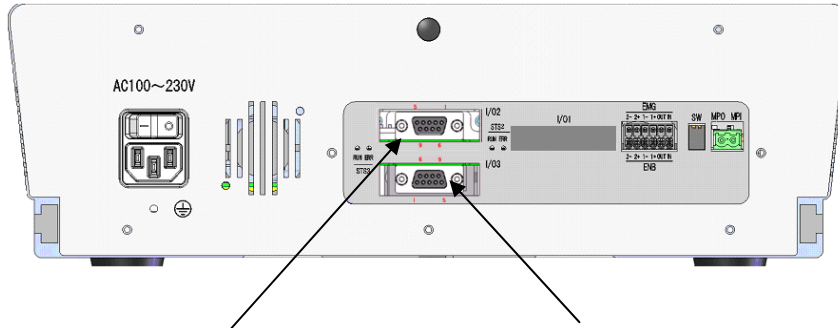

Extended Input Ports No.48 to 167  
 Extended Output Ports No.348 to 467  
 (PROFIBUS-DP board (I/O2))

Standard Input Port No.168 to 287  
 Standard Output Port No.468 to 587  
 (PROFIBUS-DP board (I/O3))

● I/O Parameters

No.	Parameter name	Default (Reference)	Input Range	Unit	Remarks
2	I/O1 Fixed Assignment Input Port Start Number	0	-1 to 599	0	0+(Multiples of 8) [Ineffective when -1 is selected]
3	I/O1 Fixed Assignment Output Port Start Number	300	-1 to 599	300	300+(Multiples of 8) [Ineffective when -1 is selected]
10	I/O1 Error Monitoring	1	0 to 5	1	0: No Monitoring (Not to use I/O board) 1: Monitoring 2: Monitoring (Not to monitor 24V I/O power related error) 3: Monitoring (To monitor only 24V I/O power related error)
14	I/O2 Fieldbus Remote Input Ports	0	0 to 256	224	8 port unit
15	I/O2 Fieldbus Remote Output Ports	0	0 to 256	224	8 port unit
16	I/O2 Fixed Assignment Input Port Start Number	-1	-1 to 599	48	48+(Multiples of 8) [Ineffective when -1 is selected]
17	I/O2 Fixed Assignment Output Port Start Number	-1	-1 to 599	348	348+(Multiples of 8) [Ineffective when -1 is selected]
18	I/O2 Error Monitoring	1	0 to 5	1	0: No Monitoring (Not to use Network I/F Module 1) 1: Monitoring
120	Network Attribute 1	640001 <sub>H</sub>	0 to FFFFFFFF <sub>H</sub>	Optional	Bits 16 to 27: Value of Link Timeout at initializing of the Fieldbus Bits 28 to 31: Input port data selected at I/O2 Fieldbus link error 0: Input port data clear 1: Input port data retained

No.	Parameter name	Default (Reference)	Input Range	Unit	Remarks
121	Network Attribute 2	0 <sub>H</sub>	0 to FFFFFFFF <sub>H</sub>	Optional	Bits 8 to 11: Input port data selected at I/O3 Fieldbus link error 0: Input port data clear 1: Input port data retained
225	Extension I/O Control	33	03 <sub>H</sub> to 33 <sub>H</sub>	-	Bits 0-3(First digit): I/O3 module type Bits 4-7(2nd digit): I/O3 module type 0: Not Mounted 1:CC-Link 2:DeviceNet 3:PROFIBUS
226	I/O2 Fieldbus Node Address	0	0 to 125	Optional	PROFIBUS-DP node address range: 1 to 125
231	I/O3 Fieldbus Remote Input Ports	0	0 to 256	120	8 port unit
232	I/O3 Fieldbus Remote Output Ports	0	0 to 256	120	8 port unit
233	I/O3 Fixed Assignment Input Port Start Number	-1	-1 to 599	168	48+(Multiples of 8) [Ineffective when -1 is selected]
234	I/O3 Fixed Assignment Output Port Start Number	-1	-1 to 599	468	348+(Multiples of 8) [Ineffective when -1 is selected]
235	I/O3 Error Monitoring	1	0 to 5	1	0: No Monitoring (Not to use CC-Link board) 1: Monitoring
237	I/O3 Fieldbus Node Address	0	0 to 125	Optional	PROFIBUS-DP node address range: 1 to 125

## 6.5 I/O Ports of the TTA

For the I/O ports, it is possible to change the specified functions except for the general-purposed I/O with the I/O parameters. [Refer to the instruction manual for the Tabletop Robot TTA for more information.]

● I/O Port Setting at Delivery

	Port No.	Function		Port No.	Function
Internal DI	000	Start	Internal DO	300	ALM (LED on the front panel)
	001	(Software reset)		301	RDY (LED on the front panel)
	002	(Servo ON)		302	EMG (LED on the front panel)
	003	(Auto program start)		303	Automatic operation mode (start switch LED)
	004	(Software interlock)		304	HPS (LED on the front panel)
	005	(Pause reset)		305	For future expansion
	006	(Pause)		306	
	007	Program number specification Ones place of the digital switch		307	
	008			308	Internal DI No. 001 ON/OFF
	009			309	Internal DI No. 002 ON/OFF
	010	Program number specification Tens place of the digital switch		310	Internal DI No. 003 ON/OFF
	011			311	Internal DI No. 004 ON/OFF
	012			312	Internal DI No. 005 ON/OFF
	013			313	Internal DI No. 006 ON/OFF
	014	(Home return, etc.)		314	For future expansion
015	315		Internal DI No. 015 ON/OFF		
External DI	016 to 031	General-purpose input (I/O connector (I/O1) on the rear panel)	External DO	316 to 331	General-purpose output (I/O connector (I/O1) on the rear panel)
Internal DI	032	For future expansion	Internal DO	332	7-segment user display digit specification
	033			333	7-segment user display digit specification
	034			334	For future expansion
	035				
	036				
	037			337	7-segment display refresh
	038			338	7-segment user/system alternate display
	039			339	7-segment user display specification
	040			340	DT0 (7-segment user display bit)
	041			341	DT1 (7-segment user display bit)
	042			342	DT2 (7-segment user display bit)
	043			343	DT3 (7-segment user display bit)
	044			344	DT4 (7-segment user display bit)
	045			345	DT5 (7-segment user display bit)
046	346	DT6 (7-segment user display bit)			
047	347	For future expansion			

External DI	048 to 287	For PROFIBUS-DP	External DO	348 to 587	For PROFIBUS-DP
-------------	------------	-----------------	-------------	------------	-----------------

Reference

When bit addresses are set in the parameter, port numbers are assigned in units of 16 points, starting from the channels corresponding to the node address set by the DIP switches.  
(This does not apply when a configurator is used.)

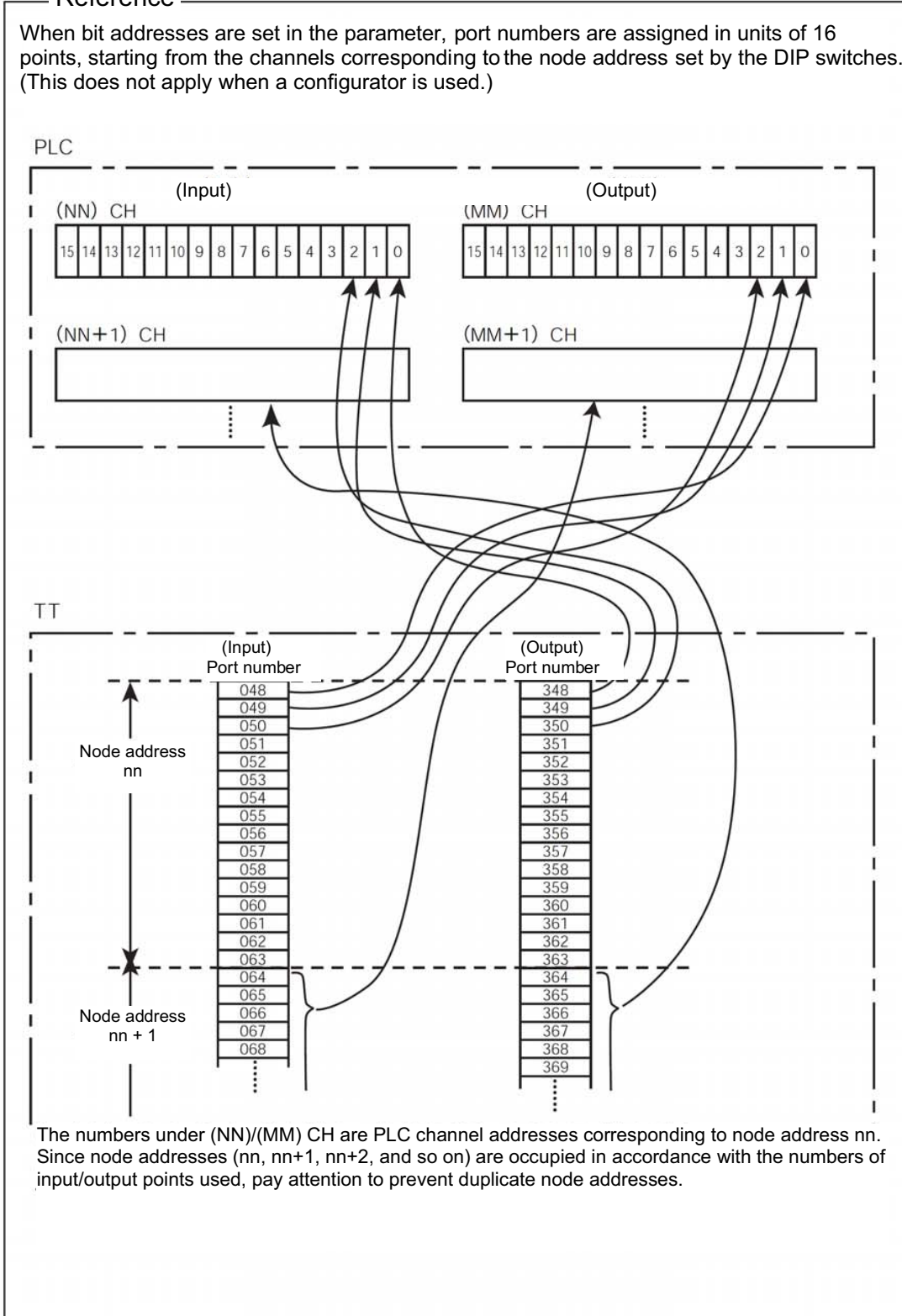

The numbers under (NN)/(MM) CH are PLC channel addresses corresponding to node address nn. Since node addresses (nn, nn+1, nn+2, and so on) are occupied in accordance with the numbers of input/output points used, pay attention to prevent duplicate node addresses.

## 6.6 Precautions

The configuration data format is applicable for the both formats of standard / special identification. However, it is necessary to make the PROFIBUS use I/O size of TTA corresponded to the size of the configuration data.

- Standard Identification Format

### Normal (compact) ID format (one byte)

Byte (octet) 1:	7	6	5	4	3	2	1	0	Bit
			0	1					ID defines <u>only</u> Input configuration
			1	0					ID defines <u>only</u> Output configuration
			1	1					ID defines Input and Output configuration
			0	0					Special ID format (use decoding table for special format)
									Number of configured data (inputs/outputs):
									00 <sub>DEC</sub> (0 <sub>HEX</sub> ) = 1 Unit (Byte/Word)
									15 <sub>DEC</sub> (F <sub>HEX</sub> ) = 16 Units (Byte/Word)
			1						Unit = Word
			0						Unit = Byte
			1						Consistency over the whole configured data block (Module)
			0						Consistency over one Unit (Byte/ Word)

- Special Identification Format

### Special (extended) ID format

#### Structure for one special configuration ID

Special Configuration ID	Previous ID	ID Header	Length OUTPUT	Length INPUT	Vendor spec. Data	next ID
	x x 0 0 x x x x		only if outputs	only if inputs	(optional)	

#### Decoding table for special format

Byte (octet) 1: Configuration ID header	7	6	5	4	3	2	1	0	Bit
			0	0					Special ID format (use decoding table for special format)
									Number of vendor specific config ID data at the end
									00 <sub>DEC</sub> (0 <sub>HEX</sub> ) = no vendor specific data
									14 <sub>DEC</sub> (E <sub>HEX</sub> ) = 14 vendor specific data
									15 <sub>DEC</sub> (F <sub>HEX</sub> ) = no vendor specific data
			0	0					Empty module, module has no input or output configuration
			0	1					One length byte for Inputs follows
			1	0					One length byte for Outputs follows
			1	1					One length byte for <u>each</u> Outputs and Inputs follows
following Byte(s) one length byte for outputs followed by the length byte for inputs, if both are defined.	7	6	5	4	3	2	1	0	Bit
									Number of configured data (inputs/outputs):
									00 <sub>DEC</sub> (0 <sub>HEX</sub> ) = 1 Unit (Byte/Word)
									63 <sub>DEC</sub> (3F <sub>HEX</sub> ) = 64 Unit (Byte/Word)
			1						Unit = Word
			0						Unit = Byte
			1						Consistency over the whole configured data block (Module)
			0						Consistency over one Unit (Byte/ Word)
following Byte(s) Vendor spec. data	7	6	5	4	3	2	1	0	Bit
									Vendor specific config ID, defined by the device vendor
									00 - 255 <sub>DEC</sub> (00 - FF <sub>HEX</sub> )

## 6.7 Troubleshooting

- 1) In case it is not possible to connect the network, check the current condition on the display of monitoring LEDs of PROFIBUS-DP Board. [Refer to Section 6.2]  
Check the settings of the TTA and the settings of the master unit referring to the instruction manuals of the master unit.
- 2) When an alarm is issued, an alarm code gets output to the panel window of the XSEL controller.
  - (1) Find the alarm code that you see on the window from the alarm code list shown below.  
Deal with it based on the description for the alarm code in question.
  - (2) In case the alarm code is not found in the following list, search in the alarm contents list contained in Tabletop Robot TTA Instruction Manual. Deal with it based on the description for the alarm code in question.

Alarm Code (Fieldbus related items are chosen below)

No.	Error name	Contents and Treatment
A6B	Fieldbus error (FBRS link error)	TTA starts up faster than the host (master unit). Change the setting in I/O Parameter No. 121 Bit 16 to23 to have the time extended before timeout.
D56	Fieldbus error (MinACK Timeout)	A communication error was detected. Check the condition of PLC, and reboot the TTA unless there is an error. If the same error occurs again, please contact us.
D59	Fieldbus error (DPRAM writing and reading)	The writing and reading error was detected in the internal memory. TTA reboot the controller. If the same error occurs again, please contact us.
D5A	Fieldbus error (TOGGLE Timeout)	A communication error was detected. TTA reboot the controller. If the same error occurs again, please contact us.
D5B	Fieldbus error (Access right retry over)	A communication board error was detected. TTA reboot the controller. If the same error occurs again, please contact us.
D5D	Fieldbus error (FBRS link error)	This occurs when the network connection is not established. 1) Check the station number, the parameters for communication speed and parameters on higher-order side. 2) It is concerned the startup of TTA is faster than that of PLC. Change the settings in I/O Parameter No. 121. [Refer to Section 6.3 [7] for the details.]
D5E	Fieldbus error (Mail BOX response)	A communication error was detected. Reboot the TTA. If the same error occurs again, please contact us.
D5F	Network I/F Module Class Mismatch Error	The setting of I/O Parameter No. 225 Network I/F Module Class does not match with that of the communication board mounted. Check the contents of the settings in I/O Parameter No. 225, and in case no doubt is found, please contact us.
D75	Fieldbus Parameter Error	There is an error in a parameter. Check I/O Parameter No. 226 and 238. Example) • A node address out of the range was set. • A communication speed out of the range is set.
D76	Fieldbus Module Unmounted Error	PROFIBUS-DP board is not mounted.
D77	Fieldbus error (Exception)	A communication board error was detected. Reboot the TTA. If the same error occurs again, please contact us.

No.	Error name	Contents and Treatment
E1F	I/O Assignment Parameter Error	It is a parameter setting error. Check to see that a number out of the I/O port number (except for -1) is not set to I/O Parameters No. 2 to 9, a number out of indication is not input to I/O port start number, or a number out of indication is not input to I/O Parameters No. 14 to 17. [Refer to TTA Instruction Manual.]
E20	I/O Duplication Assignment Error	I/O assignment is duplicated. Check to see that a number out of the I/O port number (except for -1) is not set to I/O Parameters No. 2 to 9, a number out of indication is not input to I/O port start number, or a number out of indication is not input to I/O Parameters No. 14 to 17. [Refer to TTA Instruction Manual.] Check the number of the ports that I/O boards are mounted.
E21	I/O Assignment Number Overflow Error	I/O assignment has exceeded the specified range. Check to see that a number out of the I/O port number (except for -1) is not set to I/O Parameters No. 2 to 9, a number out of indication is not input to I/O port start number, or a number out of indication is not input to I/O Parameters No. 14 to 17. [Refer to TTA Instruction Manual.] Check the number of the ports that I/O boards are mounted.
E8F	Fieldbus logic error	It is a logic error at the Fieldbus initializing.

## 7. Tabletop Robot TT

### 7.1 Model Numbers

Model number: TT-□-I-□-PR

Maximum numbers of network I/O points: 240/240

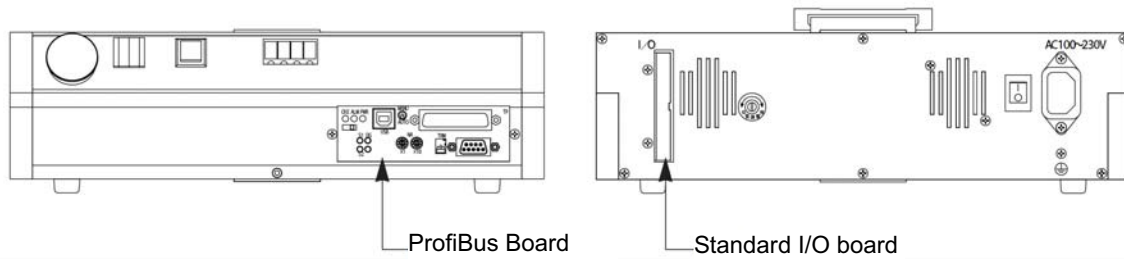

A Profibus board is installed in the installation position for field network board.

## 7.2 ProfiBus Board

### 7.2.1 Name of each part

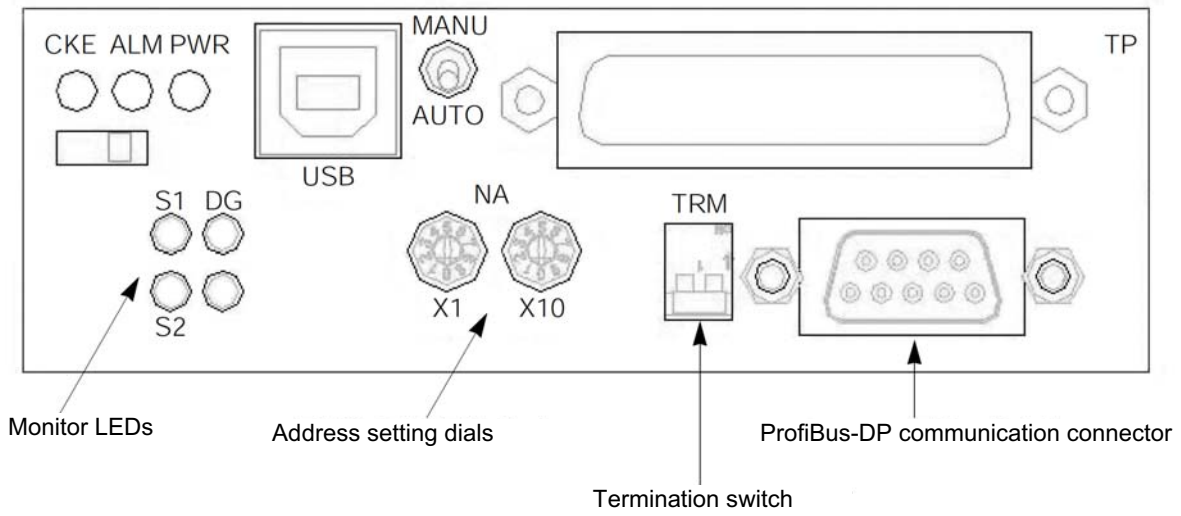

## 7.2.2 ProfiBus-DP Communication Connector

The board-end connector is a D-sub 9-pin (female) connector recommended under the ProfiBus-DP standard EN50170.

The network connector on the other end is not supplied.

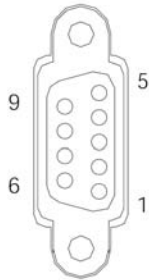

Pin No.	Signal name	Explanation
1	NC	Not connected
2	NC	Not connected
3	B-Line	Communication line B (positive side)
4	NC	Not connected
5	GND	Signal ground
6	+5V	+5-V output
7	NC	Not connected
8	A-Line	Communication line A (negative side)
9	NC	Not connected
Housing	Shield	Cable shield

\* 1, 2, 4, 6, 7 and 9 are not used. (These signals need not be wired.)

## 7.2.3 Termination switch (Bus termination settings)

Among the units connected to a ProfiBus-DP network, the devices at both ends require termination to prevent reflected waves from entering the bus line again.

This ProfiBus-DP module provides a termination switch that makes this termination easy.

The user need not install a separate terminal resistor. Never install an additional terminal resistor, as it may have negative impact on bus communication or cause a communication error, etc.

<Bus termination settings>

Termination switch ON	Termination enabled (If this switch is turned ON mistakenly when the module is connected in a position other than the end of the network, bus communication may be negatively impacted or a communication error, etc., may result.)
Termination switch OFF	Termination disabled

## 7.2.4 Address Setting Dials (Node Address Settings)

The address of each ProfiBus-DP slave station is set using the left (x1) and right (x10) address setting dials. These rotary switches set the node address of the applicable controller.

Each of these two switches can be set to a desired value in a range of 0 to 9.

Set a desired address according to the following rule:

Node address number = (Address setting dial x10) + (Address setting dial x1)

Example)

Target station number	Example of rotary switch settings	
	x 10 setting	x 1 setting
9	0	9
12	1	2

Note 1) When setting ProfiBus-DP station numbers, remember that the ProfiBus-DP master station is always assigned station number 0. Accordingly, numbers 1 to 99 are available for slave stations.

Note 2) The node address of each slave station set above cannot be changed while the slave is communicating with the master.

## 7.2.5 Monitor LED indications

LED	Color	Status	Definition	Description (cause)
	-	Not used	Not defined	
S1 Offline	Red	Steady light	Offline	<ul style="list-style-type: none"> <li>The module is not connected to the fieldbus and is therefore in "offline" state.</li> </ul>
S2 Online	Green	Steady light	Communicating normally	<ul style="list-style-type: none"> <li>The module is operating normally (The module is connected to the fieldbus and is therefore in "online" state.)</li> </ul>
DG (Error status)	Red	Unlit	No error	
		Blinking at 1 Hz	I/O size error	<ul style="list-style-type: none"> <li>This LED blinks when the specified I/O size is invalid.</li> </ul>
		Blinking at 2 Hz	Connection not yet established	<ul style="list-style-type: none"> <li>A system setting error (internal error)</li> </ul>
		Blinking at 4 Hz	Communication hardware error	<ul style="list-style-type: none"> <li>This LED blinks when a communication hardware error has been detected during the initialization of the system.</li> </ul>

## 7.3 I/O Parameter Settings (I/O Port Assignments)

The TT I/O ports used by ProfiBus are set.

### (1) Board installation position (slot) and parameter numbers

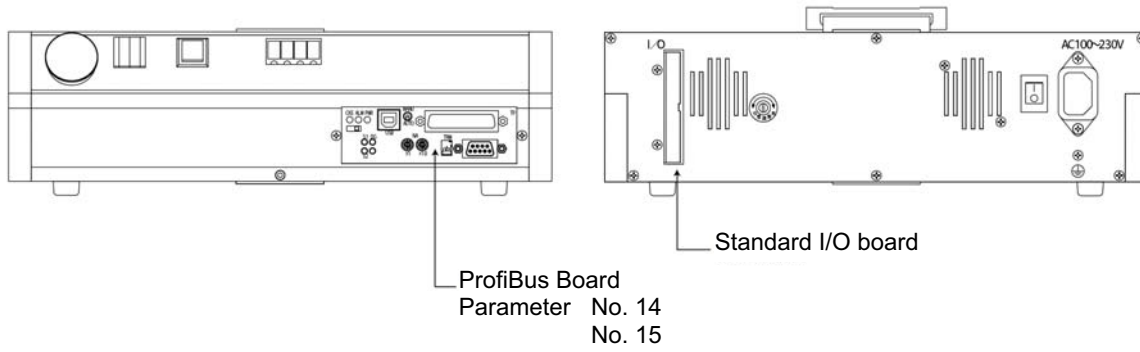

64 input ports and 64 output ports are set at the factory for use with ProfiBus.

## (2) Factory-set parameters for the TT type

No.	Parameter name	Factory-set value	Input range	Remarks
1	Input/output port assignment type	0	Read only	0: Fixed assignment
2	Standard I/O1 fixed assignment: Initial input port number	000	-1 ~ 599	0 + (multiple of 8) (The parameter is invalid if a negative value is set.)
3	Standard I/O1 fixed assignment: Initial output port number	300	-1 ~ 599	300 + (multiple of 8) (The parameter is invalid if a negative value is set.)
4	Standard I/O2 fixed assignment: Initial input port number	32	-1 ~ 599	0 + (multiple of 8) (The parameter is invalid if a negative value is set.)
5	Standard I/O2 fixed assignment: Initial output port number	316	-1 ~ 599	300 + (multiple of 8) (The parameter is invalid if a negative value is set.)
6	Expansion I/O1 fixed assignment: Initial input port number (Network I/F module)	48	-1 ~ 599	0 + (multiple of 8) (The parameter is invalid if a negative value is set.)
7	Expansion I/O1 fixed assignment: Initial output port number (Network I/F module)	348	-1 ~ 599	300 + (multiple of 8) (The parameter is invalid if a negative value is set.)
8	Reserved by system	-1	-1 ~ 599	
9	Reserved by system	-1	-1 ~ 599	
10	Standard I/O1 error monitor	0	0 ~ 5	0: Not monitored 1: Monitored 2: Monitored (24-V I/O power errors are not monitored) 3: Monitored. (Only 24-V I/O power errors are monitored.) * Some exceptions apply.
11	Standard I/O2 error monitor	0	0 ~ 5	0: Not monitored 1: Monitored 2: Monitored (24-V I/O power errors are not monitored) 3: Monitored. (Only 24-V I/O power errors are monitored.) * Some exceptions apply.
12	Expansion I/O1 error monitor (Network I/F module)	1	0 ~ 5	0: Not monitored 1: Monitored * Some exceptions apply.
13	Reserved by system	1	0 ~ 5	
14	Network I/F card remote input ports used	64	0 ~ 240	Multiple of 16
15	Network I/F card remote output ports used	64	0 ~ 240	Multiple of 16

With the TT, the numbers of ProfiBus ports to be used can be changed using the applicable parameters.

The initial ProfiBus I/O port numbers are fixed.

Initial ProfiBus input port number: 48

Initial ProfiBus output port number: 348

The standard I/O (rear panel I/O connector) port numbers are fixed.

Standard input ports: Nos. 16 to 31

Standard output ports: Nos. 316 to 331

### (3) Example of parameter settings for the tabletop robot TT

The settings below assume that 240 input points and 240 output points are assigned on the ProfiBus board as general-purpose I/O ports.

With the TT, the initial I/O port numbers are fixed.

Initial input port number: 48

Initial output port number: 348

Ports to be used are assigned in units of 16 points. Since the initial port numbers are already determined, the maximum number of ports is 240 for both input ports and output ports.

Set "240" in I/O parameter Nos. 14 and 15.

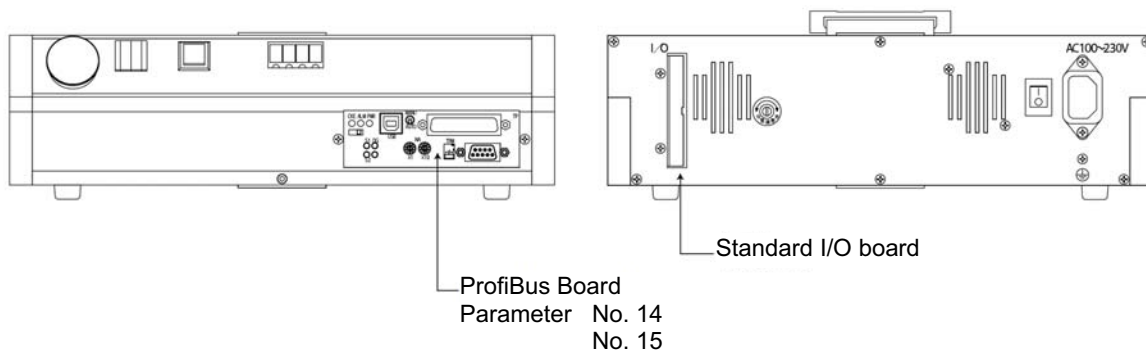

## I/O Parameters for TT Type

No.	Parameter name	Factory-set value	Input range	Set value	Remarks
1	Input/output port assignment type	0	Read only	0	0: Fixed assignment
2	Standard I/O1 fixed assignment: Initial input port number	000	Read only	000	0 + (multiple of 8) (The parameter is invalid if a negative value is set.)
3	Standard I/O1 fixed assignment: Initial output port number	300	Read only	300	300 + (multiple of 8) (The parameter is invalid if a negative value is set.)
4	Standard I/O2 fixed assignment: Initial input port number	32	Read only	32	0 + (multiple of 8) (The parameter is invalid if a negative value is set.)
5	Standard I/O2 fixed assignment: Initial output port number	316	Read only	316	300 + (multiple of 8) (The parameter is invalid if a negative value is set.)
6	Expansion I/O1 fixed assignment: Initial input port number (Network I/F module)	48	-1 ~ 599	48	0 + (multiple of 8) (The parameter is invalid if a negative value is set.)
7	Expansion I/O1 fixed assignment: Initial output port number (Network I/F module)	348	-1 ~ 599	348	300 + (multiple of 8) (The parameter is invalid if a negative value is set.)
8	Reserved by system	-1	-1 ~ 599	-1	
9	Reserved by system	-1	-1 ~ 599	-1	
10	Standard I/O1 error monitor	0	0 ~ 5	0	0: Not monitored 1: Monitored 2: Monitored (24-V I/O power errors are not monitored) 3: Monitored. (Only 24-V I/O power errors are monitored.) * Some exceptions apply.
11	Standard I/O2 error monitor	0	0 ~ 5	0	0: Not monitored 1: Monitored 2: Monitored (24-V I/O power errors are not monitored) 3: Monitored. (Only 24-V I/O power errors are monitored.) * Some exceptions apply.
12	Expansion I/O1 error monitor (Network I/F module)	1	0 ~ 5	1	0: Not monitored 1: Monitored * Some exceptions apply.
13	Reserved by system	1	0 ~ 5	1	
14	Network I/F card remote input ports used	64	0 ~ 240	240	Multiple of 16
15	Network I/F card remote output ports used	64	0 ~ 240	240	Multiple of 16

## 7.4 I/O Port Numbers for TT

The I/O port numbers applicable to the TT are shown below.  
 (For details, refer to the “Operation Manual for Tabletop Robot TT.”)

	Port No.	Function		Port No.	Function
Internal DI	000	Start	Internal DO	300	ALM (front panel LED)
	001	(Software reset)		301	RDY (front panel LED)
	002	(Servo ON)		302	EMG (front panel LED)
	003	(Auto start)		303	Auto operation mode
	004	(Software interlock)		304	HPS (front panel LED)
	005	(Pause reset)		305	Reserved by system
	006	(Pause)		306	Reserved by system
	007	Program number specification Digital switch for 1's digit		307	Reserved by system
	008			308	For ON/OFF of internal DI-No. 001
	009			309	For ON/OFF of internal DI-No. 002
	010	Program number specification Digital switch for 10's digit		310	For ON/OFF of internal DI-No. 003
	011			311	For ON/OFF of internal DI-No. 004
	012			312	For ON/OFF of internal DI-No. 005
	013	(Drive-source reset input) (Home return, etc.)		313	For ON/OFF of internal DI-No. 006
	014			314	For ON/OFF of internal DI-No. 014
015	315		For ON/OFF of internal DI-No. 015		
External DI	016 ~ 031	General-purpose input (rear panel I/O connector)	External DO	316 ~ 331	General-purpose output (rear panel I/O connector)
Internal DI	032	Reserved by system	Internal DO	332	7-segment user display digits specification
	033			333	7-segment user display digits specification
	034			334	Reserved by system
	035			335	Reserved by system
	036			336	Reserved by system
	037			337	7-segment refresh
	038			338	7-segment user/system alternate display
	039			339	7-segment user display specification
	040			340	DT0 (7-segment user display bit)
	041			341	DT1 (7-segment user display bit)
	042			342	DT2 (7-segment user display bit)
	043			343	DT3 (7-segment user display bit)
	044			344	DT4 (7-segment user display bit)
	045			345	DT5 (7-segment user display bit)
046	346	DT6 (7-segment user display bit)			
047	347	Reserved by system			
External DI	048 ~ 287	For Profibus	External DO	348 ~ 587	For Profibus

Reference

When bit addresses are set in the PLC, port numbers are assigned in units of 16 points, starting from the channels corresponding to the node address set by the DIP switches. (This does not apply when a configurator is used.)

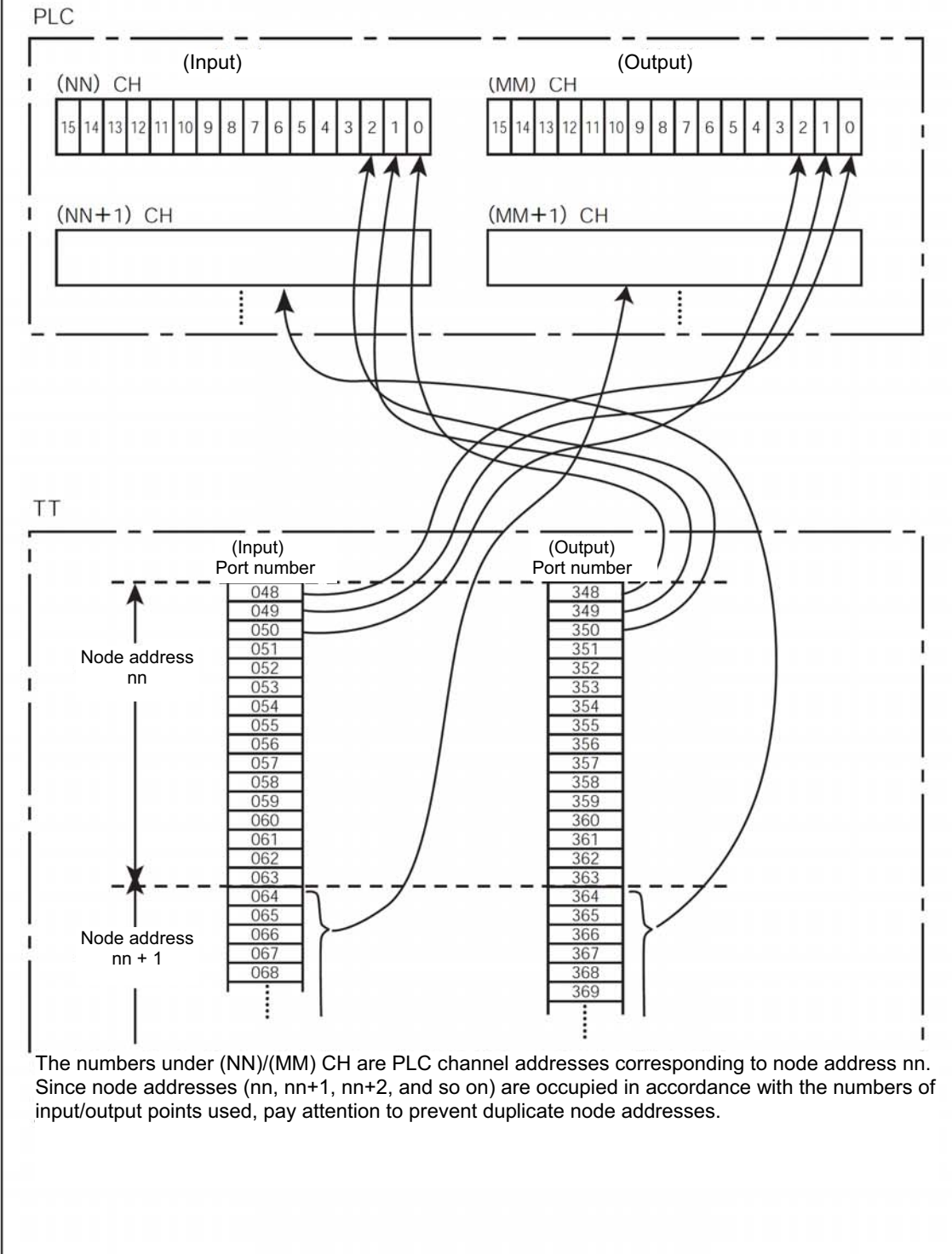

The numbers under (NN)/(MM) CH are PLC channel addresses corresponding to node address nn. Since node addresses (nn, nn+1, nn+2, and so on) are occupied in accordance with the numbers of input/output points used, pay attention to prevent duplicate node addresses.

## 8. RCS-C, E-Con and SCON

### 8.1 Model Numbers

External views (front views) of the RCS, E-Con and SCON controllers that support ProfiBus-DP are shown below.

#### (1) RCS-C

Model number: RCS-C-□□□□-□□-PR-□□

I/O points: Eight dedicated input points, 10 dedicated output points

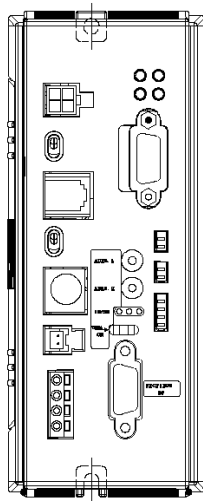

RCS-C 24-V type

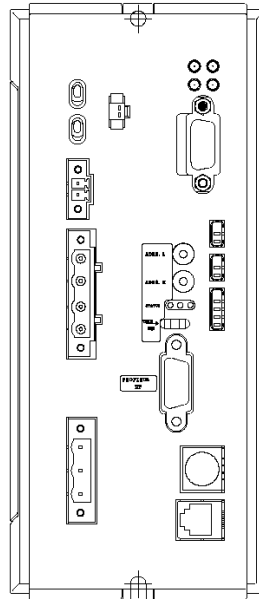

RCS-C 100/200-V type

## (2) E-Con

Model number: ECON-□-□-PR-□

I/O points: 10 dedicated input points, 12 dedicated output points

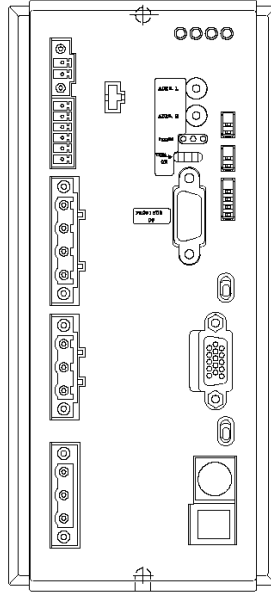

## (3) SCON

Model number: SCON-C-□□-PR-□-□

I/O points: 16 dedicated input points, 16 dedicated output points

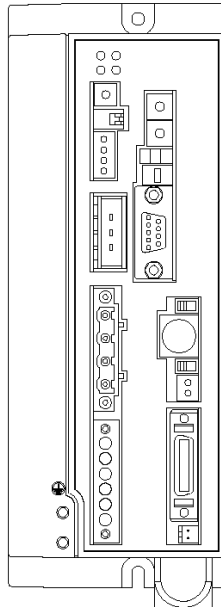

## 8.2 Setting a ProfiBus-DP Board (Slave Station)

### (1) Name of each part

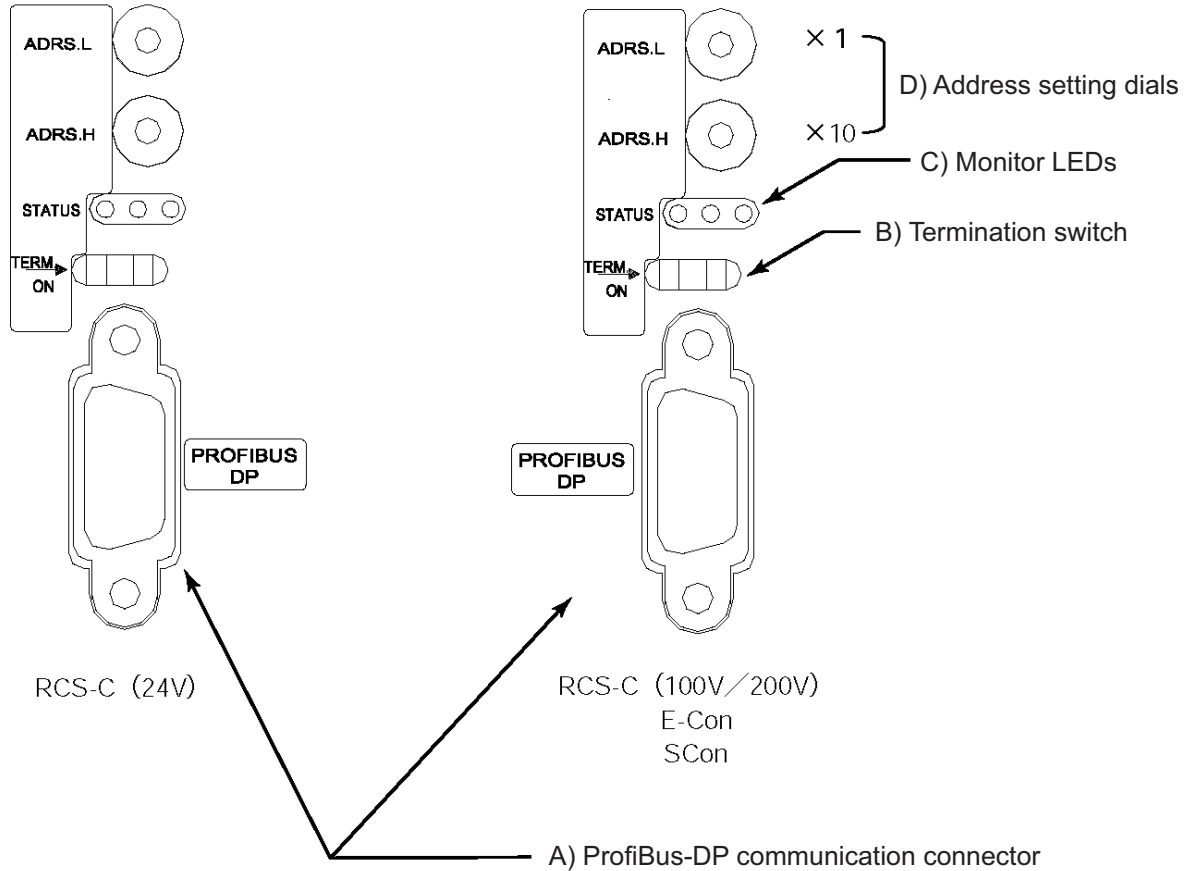

### (2) ProfiBus-DP communication connector interface specifications

<Specifications of the ProfiBus-DP communication connector (1) A>

This is a 9-pin, female D-sub connector recommended by the ProfiBus-DP standard EN 50170.

Connector

Pin No.	Description	Contents
3	B-Line	RxD/TxD (Positive signal line)
5	GND	Shield
8	A-Line	/RxD · /TxD (Negative signal line)
Housing	GND	Shield

\* Pins 1, 2, 4, 6, 7 and 9 are not used (they need not be wired).

(3) Bus termination settings <Set using the termination switch (1) B>

Among the units connected to a Profibus-DP network, the devices at both ends require termination to prevent reflected waves from entering the bus line again.

This Profibus-DP module provides a termination switch that makes this termination easy.

The user need not install a separate terminal resistor. Never install an additional terminal resistor, as it may have negative impact on bus communication or cause a communication error, etc.

<Bus termination settings>

Termination switch ON	Termination enabled (If this switch is turned ON mistakenly when the module is connected in a position other than the end of the network, bus communication may be negatively impacted or a communication error, etc., may result.)
Termination switch OFF	Termination disabled

(4) Node address settings <(Set by the address setting dials (1) D)>

The address of a slave station is set using the upper rotary switch “ADRS.H” and lower rotary switch “ADRS.L” of the station module.

These rotary switches set the node address of the applicable controller.

Each of these two switches can be set to a desired value in a range of 0 to 9.

Set the switches by following the address assignment rule below:

Node address number = (Rotary switch “ADRS.H” x 10) + (Rotary switch “ADRS.L” x 1).

Example)

Target station number	Example of rotary switch settings	
	ADRS.H setting	ADRS.L setting
9	0	9
12	1	2

Note 1) When setting Profibus-DP station numbers, remember that the Profibus-DP master station is always assigned station number 0. Accordingly, numbers 1 to 99 are available for slave stations.

Note 2) The node address of each slave station set above cannot be changed while the slave is communicating with the master.

(5) Monitor LED indications <Set by the monitor LEDs (1) C>

Of the LEDs provided on the front face of the board, the two LEDs, ERR and POWER, can be used to check the operating condition of the communication module.

The board has three LEDs, whose conditions and their meanings are explained below.

LED	Color	Status	Definition	Description (cause)
ERR	Red	Off	Communicating normally	<ul style="list-style-type: none"> <li>The module is operating normally (The module is connected to the fieldbus and is therefore in "online" state.)</li> </ul>
		On	Offline or communication error	<ul style="list-style-type: none"> <li>The module is not connected to the fieldbus and is therefore in "offline" state, or a communication error has occurred.</li> </ul>
DIA	Green	-	No function	
POWER	Green	Off	Power Off	<ul style="list-style-type: none"> <li>The ProfiBus-DP slave station is not receiving power.</li> </ul>
		On	Power ON	<ul style="list-style-type: none"> <li>The ProfiBus-DP slave station is receiving power.</li> </ul>
		Blinking at 4 Hz	Communication hardware error	<ul style="list-style-type: none"> <li>This LED blinks when a communication hardware error has been detected during the initialization of the system.</li> </ul>

(6) Input/output (I/O) signal assignments

The RCS-C, E-Con and SCON have the following numbers of inputs and outputs, respectively:

- [1] RCS-C 8 dedicated input points, 11 dedicated output points (100/200-V specification) or 10 dedicated output points (24-V specification)
- [2] E-Con 10 dedicated input points, 13 dedicated output
- [3] SCON 16 dedicated input points, 16 dedicated output

These inputs and outputs are assigned as shown below.

\* For details on each signal, refer to “Operation Manual for RCS Series ROBO Cylinder Controller RCS-C Type,” “Operation Manual for E-Con Controller” and “Operation Manual for SCON Controller.”

[1] RCS-C signal assignments

Input number	Signal name	Output number	Signal name
0	Command position 1	0	Completed position 1
1	Command position 2	1	Completed position 2
2	Command position 4	2	Completed position 4
3	Command position 8	3	Completed position 8
4	Start	4	Positioning complete
5	Reset	5	Home return complete
6	Servo on	6	Zone
7	*Pause	7	*Alarm
8	Not used	8	*Emergency stop
9	Not used	9	Moving
10	Not used	10	*Battery alarm Note)
11	Not used	11	*Not used
12	Not used	12	*Not used
13	Not used	13	*Not used
14	Not used	14	*Not used
15	Not used	15	*Not used

Note) This signal is available only when the controller’s main power supply specification is 100/200 V.

[2] E-Con signal assignments

Input number	Signal name	Output number	Signal name
0	Command position 1	0	Completed position 1
1	Command position 2	1	Completed position 2
2	Command position 4	2	Completed position 4
3	Command position 8	3	Completed position 8
4	Command position 16	4	Completed position 16
5	Command position 32	5	Completed position 32
6	Not used	6	*Not used
7	Not used	7	*Not used
8	Start	8	Positioning complete
9	Reset	9	Home return complete
10	Servo on	10	Zone
11	*Pause	11	*Alarm
12	Not used	12	*Emergency stop
13	Not used	13	Moving
14	Not used	14	*Battery alarm
15	Not used	15	*Not used

Note) The signals denoted by \* are contact-b signals (always ON).

[3] SCON signal assignments

The SCON has 16 dedicated input points and 16 dedicated output points. The details of inputs and outputs are shown below. Signals are assigned in one of six patterns in accordance with the setting of SCON parameter No. 25 (PIO pattern selection).

		Setting of parameter No. 25					
Category	Port No.	Positioning mode (standard)		Teaching mode (teaching type)		256-point mode (256-point type)	
		0		1		2	
		Signal name	Symbol	Signal name	Symbol	Signal name	Symbol
Input	0	Command position number	PC1	Command position number	PC1	Command position number	PC1
	1		PC2		PC2		PC2
	2		PC4		PC4		PC4
	3		PC8		PC8		PC8
	4		PC16		PC16		PC16
	5		PC32		PC32		PC32
	6	Cannot be used.	-	Teaching mode command (operation mode)	MODE	Cannot be used.	PC64
	7		-	Jog/inching switching	JISL		PC128
	8		-	+Jog	JOG+		-
	9	Forced brake release	BKRL	-Jog	JOG-	Forced brake release	BKRL
	10	Operation mode	RMOD	Operation mode	RMOD	Operation mode	RMOD
	11	Home return	HOME	Home return	HOME	Home return	HOME
	12	Pause	*STP	Pause	*STP	Pause	*STP
	13	Positioning start	CSTR	Positioning start/position data read command	CSTR/PWRT	Positioning start	CSTR
	14	Reset	RES	Reset	RES	Reset	RES
15	Servo ON command	SON	Servo ON command	SON	Servo ON command	SON	
Output	0	Completed position number	PM1	Completed position number	PM1	Completed position number	PM1
	1		PM2		PM2		PM2
	2		PM4		PM4		PM4
	3		PM8		PM8		PM8
	4		PM16		PM16		PM16
	5		PM32		PM32		PM32
	6	Moving signal	MOVE	Moving signal	MOVE		PM64
	7	Zone 1	ZONE1	Teaching mode signal	MODES		PM128
	8	Position zone	PZONE	Position zone	PZONE	Position zone	PZONE
	9	Operation mode	RMDS	Operation mode	RMDS	Operation mode	RMDS
	10	Home return complete	HEND	Home return complete	HEND	Home return complete	HEND
	11	Positioning complete signal	PEND	Positioning complete signal/position data read complete	PEND/WEND	Positioning complete signal	PEND
	12	Operation ready	SV	Operation ready	SV	Operation ready	SV
	13	Emergency stop	*EMGS	Emergency stop	*EMGS	Emergency stop	*EMGS
	14	Alarm	*ALM	Alarm	*ALM	Alarm	*ALM
15	Battery alarm	*BALM	Battery alarm	*BALM	Battery alarm	*BALM	

\* indicates a signal that is normally ON.

The signals denoted by "Cannot be used" are not controlled. (ON/OFF statuses of these signals are indeterminable.)

The battery alarm signal is always ON (fixed) when an incremental encoder is used.

		Setting of parameter No. 25					
Category	Port No.	512-point mode		Solenoid valve mode 1		Solenoid valve mode 2	
		3		4		5	
		Signal name	Symbol	Signal name	Symbol	Signal name	Symbol
Input	0	Command position number	PC1	Start position 0	ST0	Start position 0	ST0
	1		PC2	Start position 1	ST1	Start position 1	ST1
	2		PC4	Start position 2	ST2	Start position 2	ST2
	3		PC8	Start position 3	ST3	Cannot be used.	-
	4		PC16	Start position 4	ST4		-
	5		PC32	Start position 5	ST5		-
	6		PC64	Start position 6	ST6		-
	7		PC128	Cannot be used.	-		-
	8	PC256	-		-	-	
	9	Forced brake release	BKRL	Forced brake release	BKRL	Forced brake release	BKRL
	10	Operation mode	RMOD	Operation mode	RMOD	Operation mode	RMOD
	11	Home return	HOME	Home return	HOME	Cannot be used.	-
	12	Pause	*STP	Pause	*STP		-
	13	Positioning start	CSTR	Cannot be used.	-		-
	14	Reset	RES	Reset	RES	Reset	RES
15	Servo ON command	SON	Servo ON command	SON	Servo ON command	SON	
Output	0	Completed position number	PM1	Completed position 0	PE0	Rear end move command 0	LS0
	1		PM2	Completed position 1	PE1	Rear end move command 1	LS1
	2		PM4	Completed position 2	PE2	Rear end move command 2	LS2
	3		PM8	Completed position 3	PE3	Cannot be used.	-
	4		PM16	Completed position 4	PE4		-
	5		PM32	Completed position 5	PE5		-
	6		PM64	Completed position 6	PE6		-
	7		PM128	Zone 1	ZONE1	Zone 1	ZONE1
	8	PM256	Position zone	PZONE	Position zone	PZONE	
	9	Operation mode output	RMDS	Operation mode output	RMDS	Cannot be used.	RMDS
	10	Home return complete	HEND	Home return complete	HEND	Home return complete	HEND
	11	Positioning complete signal	PEND	Positioning complete signal	PEND	Positioning complete signal	-
	12	Operation ready	SV	Operation ready	SV	Operation ready	SV
	13	Emergency stop	*EMGS	Emergency stop	*EMGS	Emergency stop	*EMGS
	14	Alarm	*ALM	Alarm	*ALM	Alarm	*ALM
15	Battery alarm	*BALM	Battery alarm	*BALM	Battery alarm	*BALM	

\* indicates a signal that is normally ON.

The signals denoted by "Cannot be used" are not controlled. (ON/OFF statuses of these signals are indeterminable.)

The battery alarm signal is always ON (fixed) when an incremental encoder is used.

(7) Correspondence of RCS-C, E-Con and SCON I/O port numbers and PLC addresses

In the assignment of the RCS-C, E-Con or SCON's ProfiBus-DP board I/Os in the input/output (memory) areas of the PLC, one word of input/output area is occupied by 16 I/O points (dedicated inputs/outputs) of the slave station.

The table below is an example of how I/O addresses are set when a RCS-C controller (eight dedicated input points, 10 dedicated output points), E-Con controller (10 dedicated input points, 12 dedicated output points) and SCON controller (16 dedicated input points, 16 dedicated output points) are connected as slave stations to the master station.

[1] Example of system configuration

An example of system configuration is shown below.

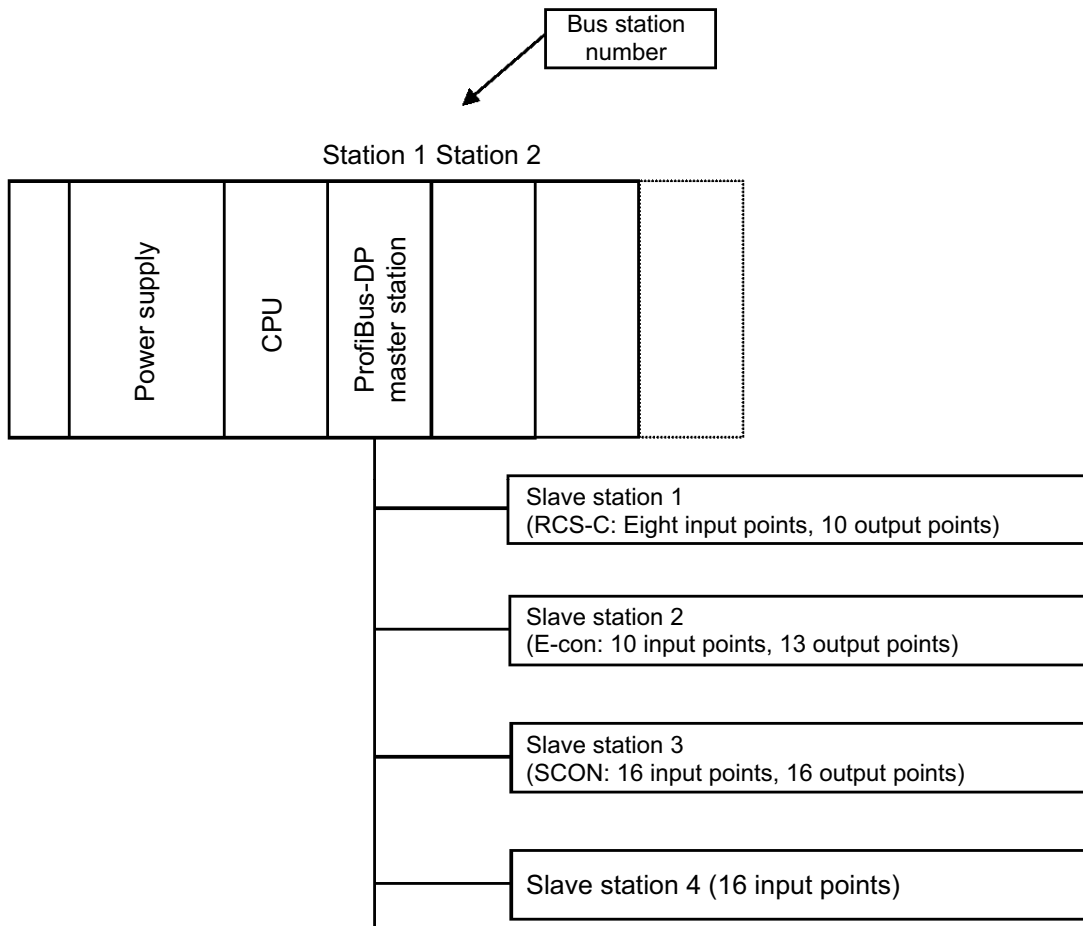

[2] Address assignment in the master station

When setting the configuration in [1] using a configurator, the numbers of inputs and outputs set for slave station 2 must be set.

(Here, it is assumed that the number of occupiable slave stations is set to eight words in the PLC master station.)

The respective I/Os are assigned addresses (bit addresses) as viewed from the PLC.

I/O port numbers are assigned in units of 16 points starting from the channel address in the PLC buffer memory corresponding to the specified node address. Here, the PLC buffer memory bits are sequentially assigned to the I/O port numbers, starting from the smallest port number and lowest memory bits. Accordingly, the PLC addresses are assigned as follows.

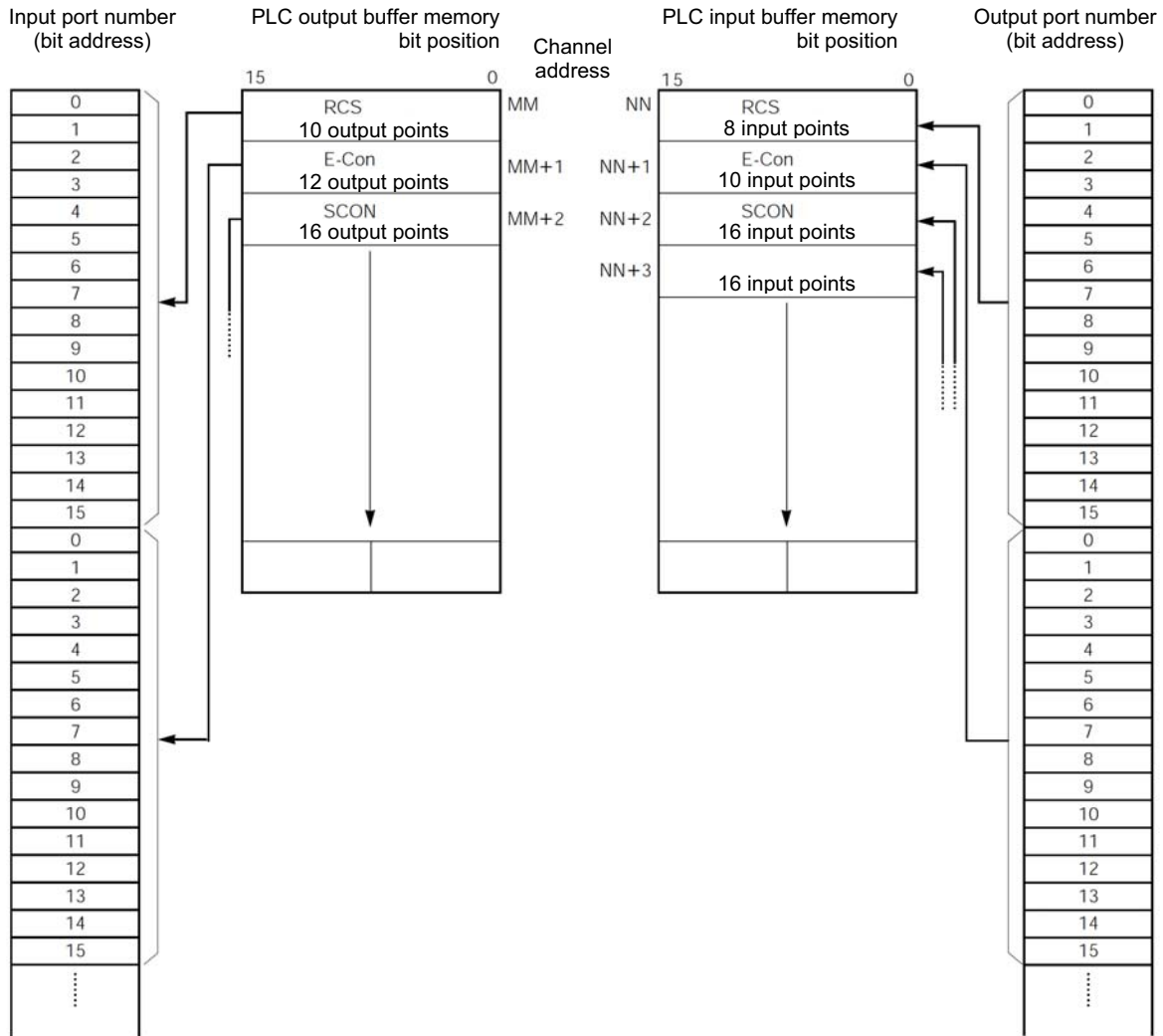

(Note) NN and MM are PLC channel addresses corresponding to node address nn. Since node addresses (nn, nn+1, nn+2, and so on) are occupied according to the numbers of I/O points used, pay attention to duplicate node address settings.

### Reference 1

When bit addresses are set in the PLC, inputs and outputs are sequentially assigned to the channels corresponding to the node address set by the DIP switches.

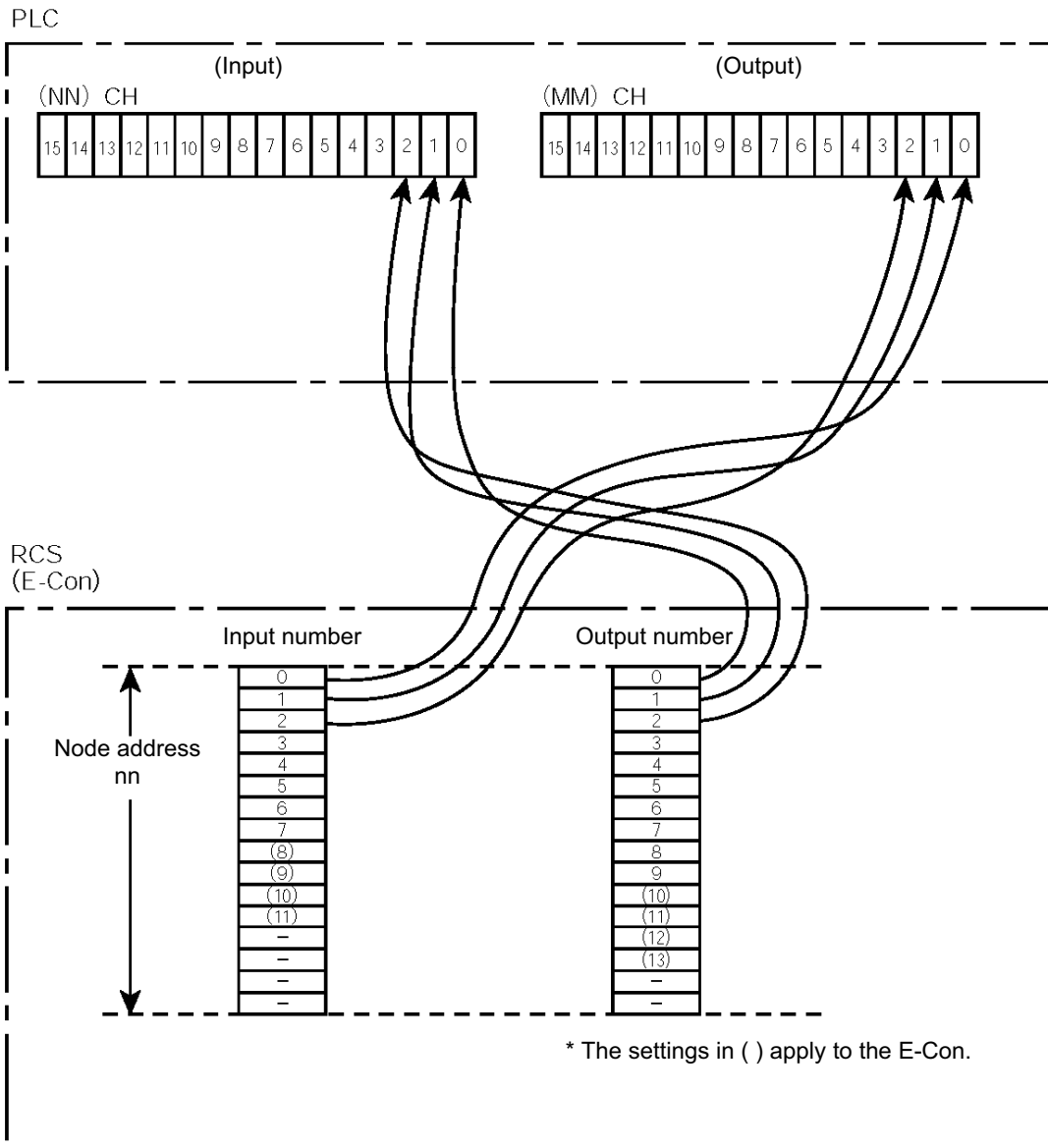

The numbers under (NN)/(MM) CH are PLC channel addresses corresponding to node address nn.

## Reference 2

Example of address assignment rules --- Fuji Electric

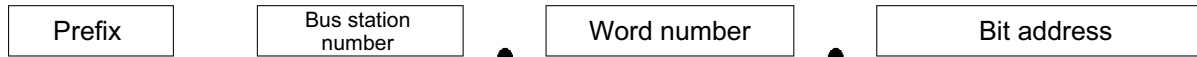

### Prefix

- %IX ... Input bit address (address per bit)
- %IW ... Input word address (address per word)
- %QX ... Output bit address (address per bit)
- %QW ... Output word address (address per word)

### Bus station number

This number indicates the installation position of the Profibus-DP board in the PLC.

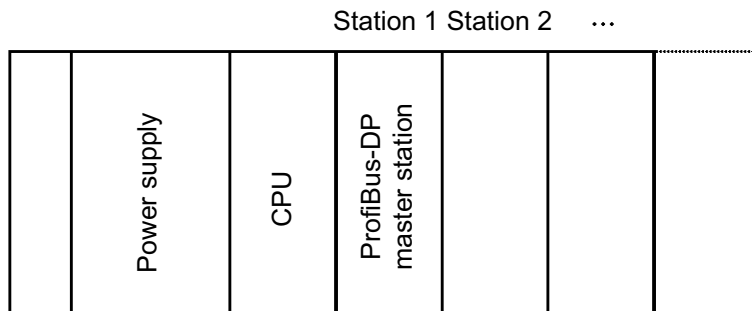

### Word number

A sequential number specifying a word when the I/Os assigned to the master station are arranged in words.

### Bit address

A sequential number specifying a bit when the I/Os assigned within each word above are arranged in bits.

## 9. ASEL, PSEL, SSEL

ASEL, PSEL and SSEL controllers of ProfiBus type can support up to 256 input points and 256 output points.

### 9.1 Model Numbers

#### 9.1.1 ASEL, PSEL

ASEL and PSEL controllers of ProfiBus type are indicated by the following model numbers:

1-axis type

ASEL-C-1-□-PR-□

PSEL-C-1-□-PR-□

2-axis type

ASEL-C-2-□-PR-□

PSEL-C-2-□-PR-□

### External view

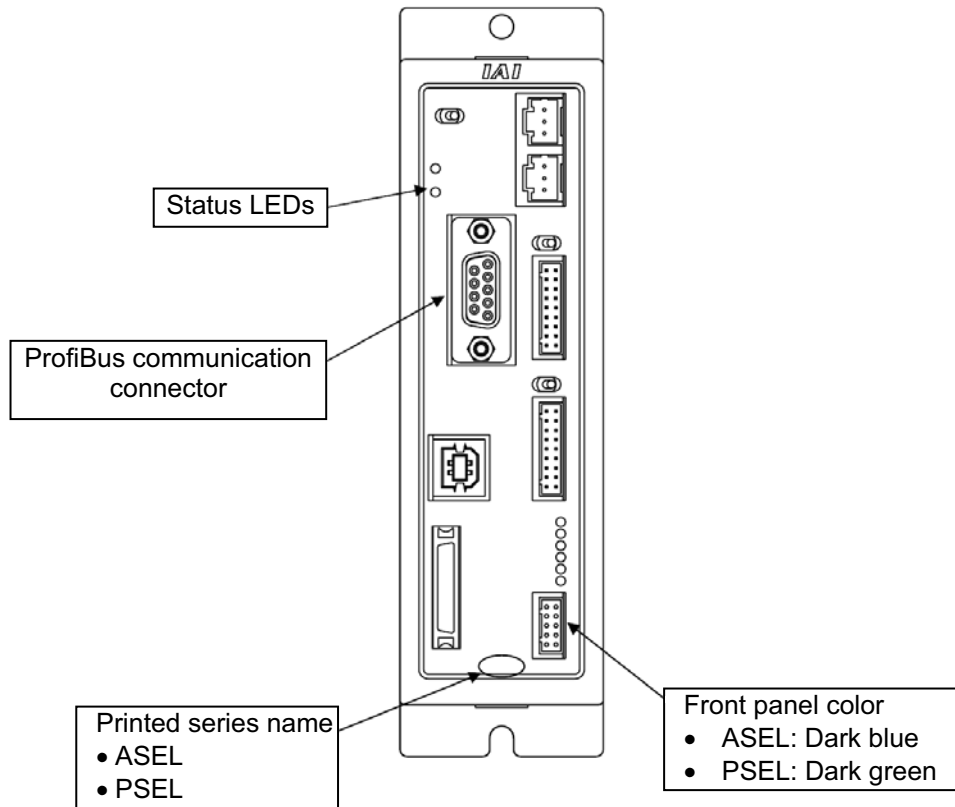

## 9.1.2 SSEL

SSEL controllers of ProfiBus type are indicated by the following model numbers:

1-axis type  
SSEL-C-1-□-PR-□

2-axis type  
SSEL-C-1-□-PR-□

### External view

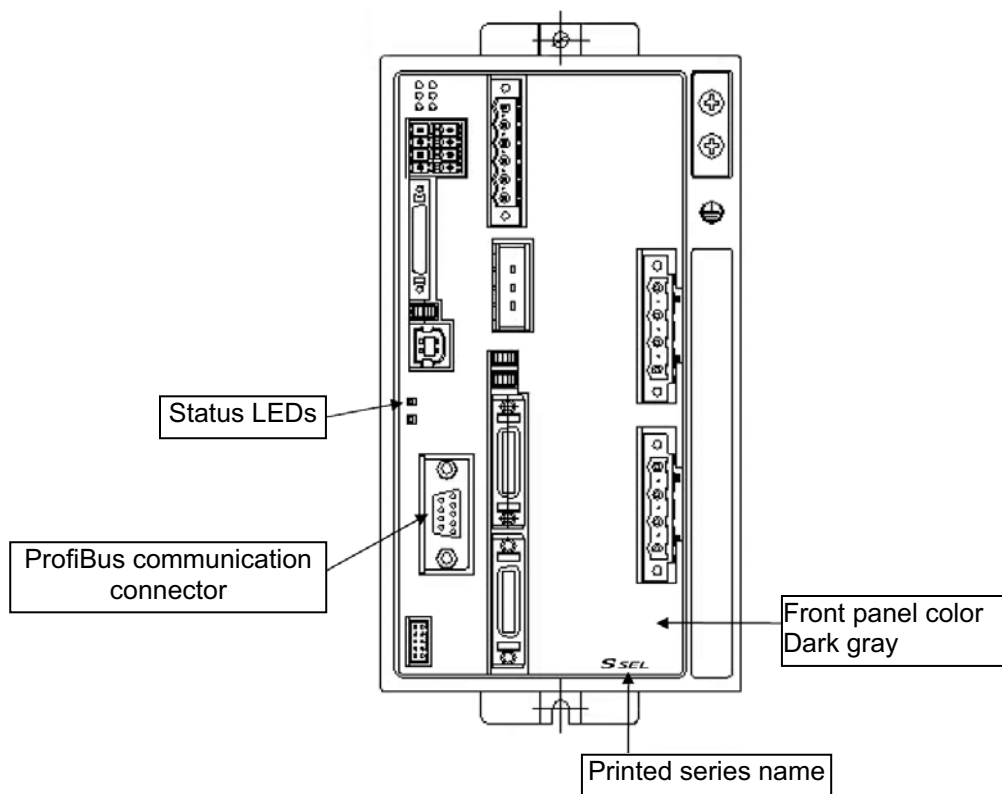

## 9.2 ProfiBus Interface

### (1) Name of each part

- ASEL, PSEL

- SSEL

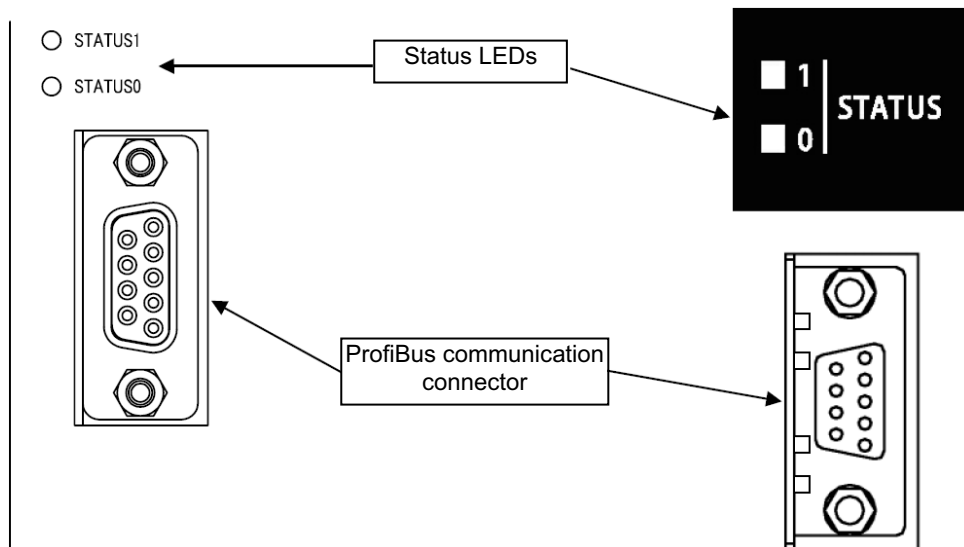

### (2) Status LED indications

The operating condition of the ProfiBus board, as well as the network condition, can be checked using the two LEDs (STATUS0 and STATUS1) provided on the front side of the board.

LED	Color	Indicator condition	Description of indication
STATUS1	Green	Lit	The board is online and communicating properly.
		Blinking	The board is online and the settings have been cleared by the master following an error.
	Orange	Blinking at 1 Hz	A network I/O parameter error is present.
		Blinking at 2 Hz	A configuration error is present.
	-	Unlit	The controller power is not supplied.
STATUS0	Green	Lit	Initialization has completed and the board is operating properly.
		Blinking	After the completion of initialization, a network diagnostic message was received from a configurator, etc., and a response has been returned.
	Orange	Lit	Exceptional error (controller failure, etc.)
	-	Unlit	<ul style="list-style-type: none"> <li>• Initialization not yet completed</li> <li>• The controller power is not supplied.</li> </ul>

---

---

MEMO

---

---

### (3) ProfiBus-DP communication connector

The board-end connector is a D-sub 9-pin (female) connector recommended under the ProfiBus-DP standard EN50170.

The network connector on the other end is not supplied.

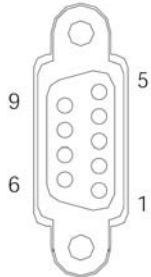

Pin No.	Signal name	Explanation
1	NC	Not connected
2	NC	Not connected
3	B-Line	Communication line B (positive side)
4	NC	Not connected
5	GND	Signal ground
6	+5V	+5-V output
7	NC	Not connected
8	A-Line	Communication line A (negative side)
9	NC	Not connected
Housing	Shield	Cable shield

**Caution**

- (1) The baud rate is automatically set according to the corresponding setting on the master side and thus need not be set.
- (2) Set the node address using I/O parameter No. 226.
- (3) No terminal resistor setting switch is provided. If the connector is to be connected to the network terminal node, connect the terminal resistor to the network connector as shown below or use a connector with terminal resistor.

● Connecting the terminal resistor

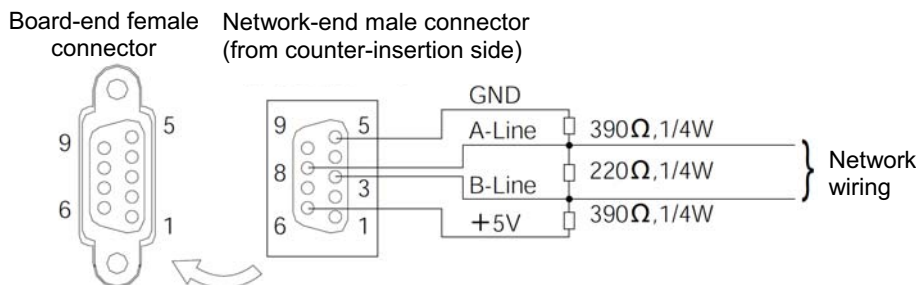

- ProfiBus connector (with terminal resistor)  
(Example) SUBCON-PLUS-PROFIB/AX/SC (Phoenix Contact)

### 9.3 I/O Parameter Settings

Set the node address, I/O ports and other parameters of the ASEL, PSEL and SSEL used with ProfiBus.

#### (1) Network type setting

I/O parameter No. 225, "Network I/F module: Control" has been set to 3H (ProfiBus) at the factory. (No additional setting is required.)

#### (2) Node address

Set the node address using I/O parameter No. 226, "Network I/F module: Communication attribute 1." The setting range is 0 to 125. This parameter has been set to 1H at the factory.

(Note) If the specified address is outside the setting range, a "D75: Fieldbus parameter error" will occur.

#### (3) I/O part assignments

In the following I/O parameters, assign the numbers of physical I/O ports and ports for the ASEL, PSEL or SSEL controller you want to use in your ProfiBus system:

No. 1	"I/O port assignment type"	} See 7.4
No. 14	"Network I/F module: Remote input ports used"	
No. 15	"Network I/F module: Remote output ports used"	
No. 16	"Network I/F module fixed assignment: Initial input port number"	
No. 17	"Network I/F module fixed assignment: Initial output port number"	

For details, refer to the ASEL, PSEL, SSEL Network I/O Parameter Table on the following page.

(Note) With ASEL, PSEL and SSEL controllers, the following I/O parameters are invalid when a ProfiBus module is used. Even if these parameters are set, they will not affect the numbers of ProfiBus ports used, assigned port numbers, etc.:

No. 2	"Standard I/O fixed assignment: Initial input port number (I/O1)"
No. 3	"Standard I/O fixed assignment: Initial output port number (I/O1)"
No. 10	"Standard I/O error monitor"

#### (4) Network error monitor

Set whether or not to monitor errors using I/O parameter No. 18, "Network I/F module: Error monitor." Set the error check time using bits 4 to 11 of I/O parameter No. 120, "Network attribute 1."

If a network link error continues for the time specified in parameter No. 120 or longer, a system error will occur.

For details, refer to the ASEL, PSEL, SSEL Network I/O Parameter Table on the following page.

ASEL, PSEL and SSEL Network I/O Parameter List

No.	Parameter name	Factory-set value	Input range	Remarks
1	Input/output port assignment type	0	0 ~ 20	0: Fixed assignment 1: Automatic assignment
14	Network I/F module: Remote input ports used	64	0 ~ 256	Multiple of 8
15	Network I/F module: Remote output ports used	64	0 ~ 256	Multiple of 8
16	Network I/F module fixed assignment: Initial input port number	0	-1 ~ 599	0 + (multiple of 8) (The parameter is invalid if a negative value is set.)
17	Network I/F module fixed assignment: Initial output port number	300	-1 ~ 599	300 + (multiple of 8) (The parameter is invalid if a negative value is set.)
18	Network I/F module: Error monitor	1	0 ~ 5	0: Not monitored 1: Monitored * If a network link error continues for the network link error check timer period or longer, a system error will occur. (Refer to I/O parameter No. 120.) * Some exceptions apply.
120	Network attribute 1	1 <sub>H</sub>	0 <sub>H</sub> ~ FFFFFFFF <sub>H</sub>	Bits 0 to 3: Reserved by system Bits 4 to 11: Network link error check timer period (set in units of 10 msec) Valid only when I/O parameter No. 18 = 1. (Example) If the set value is 05 <sub>H</sub> (bits 4 to 11), the timer period becomes 50 ms (10 ms x 5). If the set value is 0 <sub>H</sub> , a system error occurs immediately due to a network link error.
225	Network I/F module: Control	3 <sub>H</sub>	For reference only	Bits 0 to 3: Network I/F module type (0: Not installed, 1: CC-Link module, 2: DeviceNet module, 3: ProfiBus module)
226	Network I/F module: Communication attribute 1	1	0 ~ 999	Node address of network I/F module * If a ProfiBus module is used: 0 to 125
227	Network I/F module: Communication attribute 2	0 <sub>H</sub>	0 <sub>H</sub> ~ FFFFFFFF <sub>H</sub>	Bits 0 to 3: Baud rate type of network I/F module * If a ProfiBus module is used, the baud rate is automatically set according to the corresponding setting on the master side and thus need not be set.

## 9.4 I/O Port Numbers and ProfiBus-DP Address Assignments

ASEL, PSEL and SSEL controllers operate in the program mode and positioner mode, but the principles of assignment are the same with both modes. To be specific, I/O port numbers are assigned in units of 16 points starting from the channel address in the PLC buffer memory corresponding to the specified node address. Here, the PLC buffer memory bits are sequentially assigned to the I/O port numbers, starting from the smallest port number and lowest memory bits.

### (1) Basic example

The correlation diagram shown below assumes the following settings of I/O parameters:

- No. 16 = 0 (Initial input port number)
- No. 17 = 300 (Initial output port number)
- No. 14 = No.15 = 16 (Numbers of input and output ports)
- No. 226 = nn (Node address)

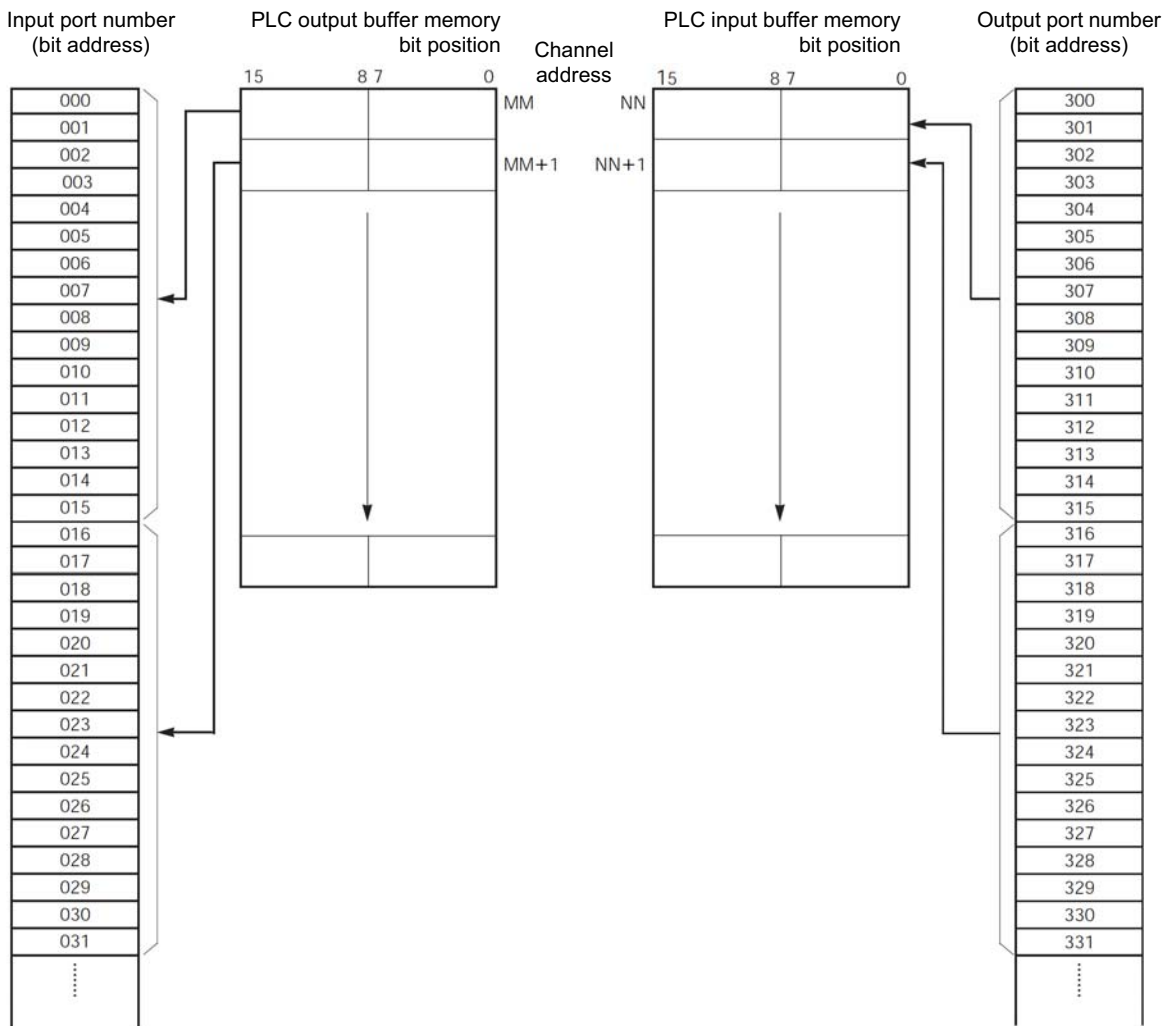

(Note) NN and MM are PLC channel addresses corresponding to node address nn. Since node addresses (nn, nn+1, nn+2, and so on) are occupied according to the numbers of I/O points used, pay attention to duplicate node address settings.

## (2) Positioner mode

Regardless of the settings of I/O parameter Nos. 1, 16 and 17, physical ports are assigned from No. 0 for input ports and from No. 300 for output ports.

As shown in the I/O port table on the next page and subsequent pages, input ports of Nos. 0 to 23 and output ports of Nos. 300 to 307 are used.

In this case, both I/O parameter Nos. 14 and 15 are set to 24.

(Note) Set the same number of points for I/O parameter Nos. 14 and 15 according to the number of input or output ports, whichever is greater.

ASEL Positioner Mode I/O Port Table

Category	Port No.	Positioner mode				
		Standard mode	Product-type switching mode	2-axis independent mode	Teaching mode	DC-S-C1 compatible mode
Input	16	Position input 10	Input 10	Position input 7	Axis 1 jog-	Position No. 1000 input
	17	Position input 11	Input 11	Position input 8	Axis 2 jog+	-
	18	Position input 12	Input 12	Position input 9	Axis 2 jog-	-
	19	Position input 13	Input 13	Position input 10	Inching (0.01 mm)	-
	20	Position input 14	Input 14	Position input 11	Inching (0.1 mm)	-
	21	-	Input 15	Position input 12	Inching (0.5 mm)	-
	22	-	Input 16	Position input 13	Inching (1 mm)	(Fixed to OFF)
	23	-	Error reset	Error reset	Error reset	CPU reset
	0	Start	Start	Axis 1 start	Start	Start
	1	Home return	Home return	Home return	Servo on	Pause
	2	Servo on	Servo on	Axis 1 servo ON	*Pause	Cancellation
	3	Push	Push	*Axis 1 pause	Position input 1	Interpolation setting
	4	*Pause	*Pause	*Axis 1 cancellation	Position input 2	Position input 1
	5	*Cancellation	*Cancellation	Axis 2 start	Position input 3	Position input 2
	6	Interpolation	Interpolation	Axis 2 home return	Position input 4	Position input 4
7	Position input 1	Input 1	Axis 2 servo ON	Position input 5	Position input 8	
8	Position input 2	Input 2	*Axis 2 pause	Position input 6	Position input 10	
9	Position input 3	Input 3	*Axis 2 cancellation	Position input 7	Position input 20	
10	Position input 4	Input 4	Position input 1	Position input 8	Position input 40	
11	Position input 5	Input 5	Position input 2	Position input 9	Position input 80	
12	Position input 6	Input 6	Position input 3	Position input 10	Position input 100	
13	Position input 7	Input 7	Position input 4	Position input 11	Position input 200	
14	Position input 8	Input 8	Position input 5	Specifying teaching mode	Position input 400	
15	Position input 9	Input 9	Position input 6	Axis 1 jog+	Position input 800	
Output	300	*Alarm	*Alarm	*Alarm	*Alarm	Alarm
	301	Ready	Ready	Ready	Ready	Ready
	302	Positioning compete	Positioning compete	Axis 1 positioning complete	Positioning compete	Positioning compete
	303	Home return complete	Home return complete	Axis 1 home return complete	Home return complete	-
	304	Servo ON output	Servo ON output	Axis 1 servo ON	Servo ON output	-
	305	Push complete	Push complete	Axis 2 positioning complete		-
	306	System battery error	System battery error	Axis 2 home return complete	System battery error	System battery error
307	Absolute battery error	Absolute battery error	Axis 2 servo ON	Absolute battery error	Absolute battery error	

\*: Contact B (negative logic)

PSEL Positioner Mode I/O Port Table

Category	Port No.	Positioner mode				
		Standard mode	Product-type switching mode	2-axis independent mode	Teaching mode	DC-S-C1 compatible mode
Input	16	Position input 10	Input 10	Position input 7	Axis 1 jog-	Position No. 1000 input
	17	Position input 11	Input 11	Position input 8	Axis 2 jog+	-
	18	Position input 12	Input 12	Position input 9	Axis 2 jog-	-
	19	Position input 13	Input 13	Position input 10	Inching (0.01 mm)	-
	20	-	Input 14	Position input 11	Inching (0.1 mm)	-
	21	-	Input 15	Position input 12	Inching (0.5 mm)	-
	22	-	Input 16	Position input 13	Inching (1 mm)	(Fixed to OFF)
	23	Error reset	Error reset	Error reset	Error reset	CPU reset
	0	Start	Start	Axis 1 start	Start	Start
	1	Home return	Home return	Home return	Servo on	Pause
	2	Servo on	Servo on	Axis 1 servo ON	*Pause	Cancellation
	3	Push	Push	*Axis 1 pause	Position input 1	Interpolation setting
	4	*Pause	*Pause	*Axis 1 cancellation	Position input 2	Position input 1
	5	*Cancellation	*Cancellation	Axis 2 start	Position input 3	Position input 2
	6	Interpolation	Interpolation	Axis 2 home return	Position input 4	Position input 4
7	Position input 1	Input 1	Axis 2 servo ON	Position input 5	Position input 8	
8	Position input 2	Input 2	*Axis 2 pause	Position input 6	Position input 10	
9	Position input 3	Input 3	*Axis 2 cancellation	Position input 7	Position input 20	
10	Position input 4	Input 4	Position input 1	Position input 8	Position input 40	
11	Position input 5	Input 5	Position input 2	Position input 9	Position input 80	
12	Position input 6	Input 6	Position input 3	Position input 10	Position input 100	
13	Position input 7	Input 7	Position input 4	Position input 11	Position input 200	
14	Position input 8	Input 8	Position input 5	Specifying teaching mode	Position input 400	
15	Position input 9	Input 9	Position input 6	Axis 1 jog+	Position input 800	
Output	300	*Alarm	*Alarm	*Alarm	*Alarm	Alarm
	301	Ready	Ready	Ready	Ready	Ready
	302	Positioning compete	Positioning compete	Axis 1 positioning complete	Positioning compete	Positioning compete
	303	Home return complete	Home return complete	Axis 1 home return complete	Home return complete	-
	304	Servo ON output	Servo ON output	Axis 1 servo ON	Servo ON output	-
	305	Push complete	Push complete	Axis 2 positioning complete		-
	306	System battery error	System battery error	Axis 2 home return complete	System battery error	System battery error
307	-	-	Axis 2 servo ON	-	-	

\*: Contact B (negative logic)

SSEL Positioner Mode I/O Port Table

Category	Port No.	Positioner mode				
		Standard mode	Product-type switching mode	2-axis independent mode	Teaching mode	DC-S-C1 compatible mode
Input	16	Position input 10	Input 10	Position input 7	Axis 1 jog-	Position No. 1000 input
	17	Position input 11	Input 11	Position input 8	Axis 2 jog+	Position No. 2000 input
	18	Position input 12	Input 12	Position input 9	Axis 2 jog-	Position No. 4000 input
	19	Position input 13	Input 13	Position input 10	Inching (0.01 mm)	Position No. 8000 input
	20	Position input 14	Input 14	Position input 11	Inching (0.1 mm)	Position No. 10000 input
	21	Position input 15	Input 15	Position input 12	Inching (0.5 mm)	Position No. 20000 input
	22	Position input 16	Input 16	Position input 13	Inching (1 mm)	(Fixed to OFF)
	23	Error reset	Error reset	Error reset	Error reset	CPU reset
	0	Start	Start	Axis 1 start	Start	Start
	1	Home return	Home return	Home return	Servo on	Pause
	2	Servo on	Servo on	Axis 1 servo ON	*Pause	Cancellation
	3	Push	Push	*Axis 1 pause	Position input 1	Interpolation setting
	4	*Pause	*Pause	*Axis 1 cancellation	Position input 2	Position input 1
	5	*Cancellation	*Cancellation	Axis 2 start	Position input 3	Position input 2
	6	Interpolation	Interpolation	Axis 2 home return	Position input 4	Position input 4
	7	Position input 1	Input 1	Axis 2 servo ON	Position input 5	Position input 8
	8	Position input 2	Input 2	*Axis 2 pause	Position input 6	Position input 10
	9	Position input 3	Input 3	*Axis 2 cancellation	Position input 7	Position input 20
	10	Position input 4	Input 4	Position input 1	Position input 8	Position input 40
	11	Position input 5	Input 5	Position input 2	Position input 9	Position input 80
12	Position input 6	Input 6	Position input 3	Position input 10	Position input 100	
13	Position input 7	Input 7	Position input 4	Position input 11	Position input 200	
14	Position input 8	Input 8	Position input 5	Specifying teaching mode	Position input 400	
15	Position input 9	Input 9	Position input 6	Axis 1 jog+	Position input 800	
Output	300	*Alarm	*Alarm	*Alarm	*Alarm	Alarm
	301	Ready	Ready	Ready	Ready	Ready
	302	Positioning compete	Positioning compete	Axis 1 positioning complete	Positioning compete	Positioning compete
	303	Home return complete	Home return complete	Axis 1 home return complete	Home return complete	-
	304	Servo ON output	Servo ON output	Axis 1 servo ON	Servo ON output	-
	305	Push complete	Push complete	Axis 2 positioning complete		-
	306	System battery error	System battery error	Axis 2 home return complete	System battery error	System battery error
	307	Absolute battery error	Absolute battery error	Axis 2 servo ON	Absolute battery error	Absolute battery error

\*: Contact B (negative logic)

## 10. Common Items and Others

### 10.1 Communication Cable

For connection cables, use type A cables conforming to the ProfiBus standard.

### 10.2 Useful Function When Adjusting an X-SEL Controller

- (1) If a standard or expansion I/O board is installed in an X-SEL K-type controller, the controller can be started alone without connecting a 24-VDC I/O power supply.
- (2) If a ProfiBus-DP board is installed in an X-SEL controller, the controller can be started alone even when the network is not yet established.

In either case, set one of I/O parameter Nos. 10 to 13, whichever is applicable, to "0: Not monitored."

(Note) After all necessary operations and adjustments have been completed, be sure to reset the parameter to the original setting. If the parameter is not reset, the board in the applicable slot will not be checked for errors.

### 10.3 GDS Files

For the ProfiBus-DP configurator, use the configurator recommended for the master unit. If GDS files are needed to use the recommended configurator, download the applicable files from IAI's website specified below:

Website: [www.intelligentactuator.com](http://www.intelligentactuator.com)

For a ProfiBus-DP configurator to become effective, the GDS files supplied with the product must be installed and this device must be set on the master side. When setting the device in the master, use the numbers of input and output ports specified in the X-SEL(TT), RCS-C, E-Con, SCON, ACON, PCON, ASEL, PSEL or SSEL controller for the numbers of input and output bytes.

Once the necessary settings have been made using the configurator, the system will automatically communicate with the network next time the system is started. For the method to set the slave station (X-SEL(TT), RCS-C, E-Con, SCON, ACON, PCON, ASEL, PSEL or SSEL) information in the master station, follow the operation manuals for the master station, PLC in which the master station is installed, and any applicable peripheral equipment.

## Change History

Revision Date	Description of Revision
	First edition
October 2006	Second edition <ul style="list-style-type: none"> <li>• P24 to 34: Added SCON in Section 4.</li> </ul>
November 2006	Third edition <ul style="list-style-type: none"> <li>• Table of Contents: Changed the pages after 4.2 (7).</li> <li>• P25: Corrected the number of dedicated input points for SCON from 13 to 16.</li> <li>• P29: Corrected the number of dedicated input points for SCON from 13 to 16.</li> <li>• P30: Deleted the signal assignments for SCON in [3].</li> <li>• P31: Added the standard type, teaching type and 256-point type in the SCON signal assignment table.</li> <li>• P32: Added the 512-point type, 7-point type and 3-point type in the SCON signal assignment table.</li> <li>• P33: Corrected the number of dedicated input points for SCON from 13 to 16. Changed the number of pages.</li> <li>• P34: Changed the number of pages.</li> <li>• P35: Changed the number of pages. Corrected the number of input points for SCON from 13 to 16.</li> <li>• P36 to 40: Changed the number of pages.</li> </ul>
February 2008	Fourth edition <ul style="list-style-type: none"> <li>• Table of Contents: Added TT in Section 4 and SSEL in Section 6.</li> <li>• P1: Added TT and SSEL in the illustration.</li> <li>• P25 to 33: Added descriptions regarding TT in Section 4 (and changed the number of pages constituting Section 5 accordingly).</li> <li>• P47 to 55: Added descriptions regarding SSEL in Section 6.</li> </ul>
March 2008	Fifth edition <ul style="list-style-type: none"> <li>• P1: Provided a descriptive summary for each controller under "Each Controller." Added ACON and PCON in the connection diagram.</li> <li>• P2: Deleted the sample program name of the configurator (because this is an old program).</li> <li>• P20 to 22: Changed addresses to more general descriptions because the original addresses were those of a specific manufacturer (Fuji Electric).</li> <li>• P41 to 42: Corrected signal names in the PIO signal assignment table for SCON.</li> <li>• P44 to 45: Changed addresses to more general descriptions because the original addresses were those of a specific manufacturer (Fuji Electric).</li> <li>• P56 to 126: Added explanations regarding ACON and PCON anew.</li> <li>• P127: Added ACON and PCON.</li> </ul>



Revision Date	Description of Revision
April 2008	Sixth edition <ul style="list-style-type: none"> <li>• Corrected clerical errors.</li> </ul> Seventh edition <ul style="list-style-type: none"> <li>• Missing number</li> </ul>
September 2008	Eighth edition <ul style="list-style-type: none"> <li>• P1: Added ASEL and PSEL.</li> <li>• P3: Added the P/Q/PX/QX types to XSEL.</li> <li>• P55: Added ASEL and PSEL.</li> <li>• P138: Added related information because ACON and PCON were CE certified.</li> </ul>
May 2010	Ninth edition <ul style="list-style-type: none"> <li>• Added "Please Read Before Use" on the first page after the cover.</li> <li>• Added "Safety Guide" on the first page after the table of contents.</li> <li>• Added "Change History" on the last page.</li> <li>• Updated the back cover. (Changed the addresses of the head office and sales offices, indicated the 24-hour service of Eight, etc.)</li> </ul>
November 2011	Eleventh edition <ul style="list-style-type: none"> <li>• Contents changed in Safety Guide Caution notes added for when working with two or more persons</li> <li>• Deleted ACON and PCON.</li> </ul>
July 2012	Twelfth edition <ul style="list-style-type: none"> <li>• Contents changed in Safety Guide</li> <li>• P9 Part Number "J/K/P/Q/JX/KX/PX/QX" added on "3. X-SEL"</li> <li>• P38 to 53 4. XSEL-R/S/RX/SX/RXD/SXD on added</li> </ul>
September 2013	Thirteenth edition <ul style="list-style-type: none"> <li>• 5. Tabletop Robot TTA on added</li> </ul>
May 2014	Fourteenth edition <ul style="list-style-type: none"> <li>• 5. MSEL on added</li> </ul>
August 2014	Edition 14B <ul style="list-style-type: none"> <li>• Made applicable for MSEL Cartesian Type</li> </ul>
July 2016	Fifteenth edition <ul style="list-style-type: none"> <li>• XSEL-RA/SA series added</li> </ul>





## ***IAI Corporation***

Head Office: 577-1 Obane Shimizu-KU Shizuoka City Shizuoka 424-0103, Japan  
TEL +81-54-364-5105 FAX +81-54-364-2589  
website: [www.iai-robot.co.jp/](http://www.iai-robot.co.jp/)

Technical Support available in USA, Europe and China

## ***IAI America, Inc.***

Head Office: 2690 W. 237th Street, Torrance, CA 90505  
TEL (310) 891-6015 FAX (310) 891-0815  
Chicago Office: 110 East State Parkway, Schaumburg, IL 60173  
TEL (847) 908-1400 FAX (847) 908-1399  
Atlanta Office: 1220 Kennestone Circle, Suite 108, Marietta, GA 30066  
TEL (678) 354-9470 FAX (678) 354-9471  
website: [www.intelligentactuator.com](http://www.intelligentactuator.com)

## ***IAI Industrieroboter GmbH***

Ober der Röth 4, D-65824 Schwalbach am Taunus, Germany  
TEL 06196-88950 FAX 06196-889524

## ***IAI (Shanghai) Co., Ltd.***

SHANGHAI JIAHUA BUSINESS CENTER A8-303, 808, Hongqiao Rd. Shanghai 200030, China  
TEL 021-6448-4753 FAX 021-6448-3992  
website: [www.iai-robot.com](http://www.iai-robot.com)

## ***IAI Robot (Thailand) Co., Ltd.***

825 PhairojKijja Tower 12th Floor, Bangna-Trad RD., Bangna, Bangkok 10260, Thailand  
TEL +66-2-361-4458 FAX +66-2-361-4456